



### GENERAL DESCRIPTION



The ICS85310I-01 is a low skew, high performance 1-to-10 Differential-to-2.5V/3.3V ECL/LVPECL Fanout Buffer and a member of the HiPerClockS™ family of High Performance Clock Solutions from ICS. The CLKx, nCLKx pairs can accept most standard differential input levels. The ICS85310I-01 is characterized to operate from either a 2.5V or a 3.3V power supply. Guaranteed output and part-to-part skew characteristics make the ICS85310I-01 ideal for those clock distribution applications demanding well defined performance and repeatability.

### FEATURES

- Ten differential 2.5V/3.3V LVPECL / ECL outputs
- Two selectable differential input pairs
- CLKx, nCLKx pairs can accept the following differential input levels: LVPECL, LVDS, LVHSTL, SSTL, HCSL
- Maximum output frequency: 700MHz
- Translates any single ended input signal to 3.3V LVPECL levels with resistor bias on nCLK input
- Output skew: 30ps (typical)
- Part-to-part skew: 140ps (typical)
- Propagation delay: 2ns (typical)
- Additive phase jitter, RMS: <0.13ps (typical)
- LVPECL mode operating voltage supply range:  $V_{CC} = 2.375V$  to  $3.8V$ ,  $V_{EE} = 0V$
- ECL mode operating voltage supply range:  $V_{CC} = 0V$ ,  $V_{EE} = -2.375V$  to  $-3.8V$
- -40°C to 85°C ambient operating temperature
- Available in both standard and lead-free RoHS compliant packages

### BLOCK DIAGRAM

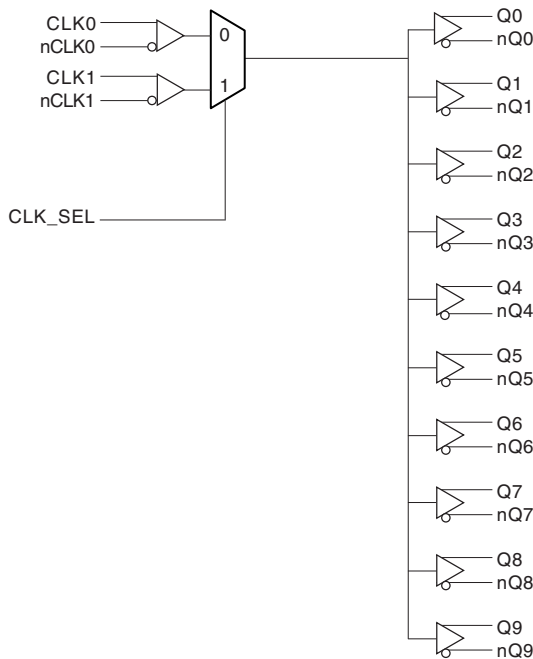

### PIN ASSIGNMENT

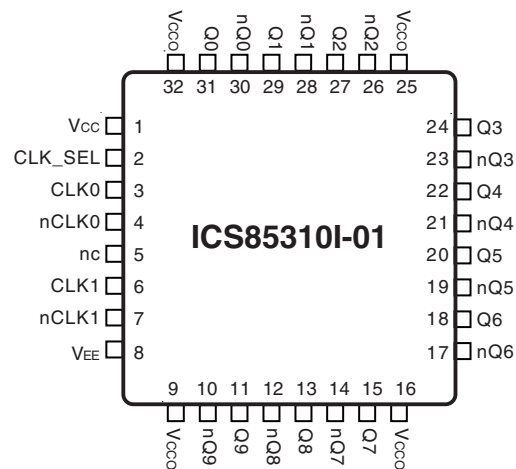

**32-Lead LQFP**  
7mm x 7mm x 1.4mm package body  
**Y Package**  
Top View



**TABLE 1. PIN DESCRIPTIONS**

Number	Name	Type		Description
1	V <sub>CC</sub>	Power		Positive supply pin.
2	CLK_SEL	Input	Pulldown	Clock select input. When HIGH, selects CLK1, nCLK1 inputs. When LOW, selects CLK0, nCLK0 inputs. LVCMOS / LVTTTL interface levels.
3	CLK0	Input	Pulldown	Non-inverting differential clock input.
4	nCLK0	Input	Pullup	Inverting differential clock input.
5	nc	Unused		No connect.
6	CLK1	Input	Pulldown	Non-inverting differential clock input.
7	nCLK1	Input	Pullup	Inverting differential clock input.
8	V <sub>EE</sub>	Power		Negative supply pin.
9, 16, 25, 32	V <sub>CCO</sub>	Power		Output supply pins.
10, 11	nQ9, Q9	Output		Differential output pair. LVPECL interface levels.
12, 13	nQ8, Q8	Output		Differential output pair. LVPECL interface levels.
14, 15	nQ7, Q7	Output		Differential output pair. LVPECL interface levels.
17, 18	nQ6, Q6	Output		Differential output pair. LVPECL interface levels.
19, 20	nQ5, Q5	Output		Differential output pair. LVPECL interface levels.
21, 22	nQ4, Q4	Output		Differential output pair. LVPECL interface levels.
23, 24	nQ3, Q3	Output		Differential output pair. LVPECL interface levels.
26, 27	nQ2, Q2	Output		Differential output pair. LVPECL interface levels.
28, 29	nQ1, Q1	Output		Differential output pair. LVPECL interface levels.
30, 31	nQ0, Q0	Output		Differential output pair. LVPECL interface levels.

NOTE: *Pullup* and *Pulldown* refer to internal input resistors. See Table 2, Pin Characteristics, for typical values.

**TABLE 2. PIN CHARACTERISTICS**

Symbol	Parameter	Test Conditions	Minimum	Typical	Maximum	Units
C <sub>IN</sub>	Input Capacitance			4		pF
R <sub>PULLUP</sub>	Input Pullup Resistor			51		kΩ
R <sub>PULLDOWN</sub>	Input Pulldown Resistor			51		kΩ



**ABSOLUTE MAXIMUM RATINGS**

Supply Voltage, $V_{CC}$	4.6V
Inputs, $V_i$	-0.5V to $V_{CC} + 0.5V$
Outputs, $I_o$	
Continuous Current	50mA
Surge Current	100mA
Package Thermal Impedance, $\theta_{JA}$	47.9°C/W (0 lfpm)
Storage Temperature, $T_{STG}$	-65°C to 150°C

NOTE: Stresses beyond those listed under Absolute Maximum Ratings may cause permanent damage to the device. These ratings are stress specifications only. Functional operation of product at these conditions or any conditions beyond those listed in the *DC Characteristics* or *AC Characteristics* is not implied. Exposure to absolute maximum rating conditions for extended periods may affect product reliability.

**TABLE 3A. POWER SUPPLY DC CHARACTERISTICS,  $V_{CC} = V_{CCO} = 2.375V$  TO  $3.8V$ ,  $T_A = -40^\circ C$  TO  $85^\circ C$**

Symbol	Parameter	Test Conditions	Minimum	Typical	Maximum	Units
$V_{CC}$	Positive Supply Voltage		2.375	3.3	3.8	V
$V_{CCO}$	Output Supply Voltage		2.375	3.3	3.8	V
$I_{EE}$	Power Supply Current				120	mA

**Table 3B. LVCMOS/LVTTL DC Characteristics,  $V_{CC} = V_{CCO} = 2.375V$  TO  $3.8V$ ,  $T_A = -40^\circ C$  TO  $85^\circ C$**

Symbol	Parameter	Test Conditions	Minimum	Typical	Maximum	Units
$V_{IH}$	Input High Voltage	CLK_SEL	2		$V_{CC} + 0.3$	V
$V_{IL}$	Input Low Voltage	CLK_SEL	-0.3		0.8	V
$I_{IH}$	Input High Current	CLK_SEL $V_{CC} = V_{IN} = 3.8V$	-5			$\mu A$
$I_{IL}$	Input Low Current	CLK_SEL $V_{CC} = 3.8V, V_{IN} = 0V$			150	$\mu A$

**TABLE 3C. DIFFERENTIAL DC CHARACTERISTICS,  $V_{CC} = V_{CCO} = 2.375V$  TO  $3.8V$ ,  $T_A = -40^\circ C$  TO  $85^\circ C$**

Symbol	Parameter	Test Conditions	Minimum	Typical	Maximum	Units
$I_{IH}$	Input High Current	CLK0, CLK1 $V_{CC} = V_{IN} = 3.8V$			150	$\mu A$
		nCLK0, nCLK1 $V_{CC} = V_{IN} = 3.8V$			5	$\mu A$
$I_{IL}$	Input Low Current	CLK0, CLK1 $V_{CC} = 3.8V, V_{IN} = 0V$	-5			$\mu A$
		nCLK0, nCLK1 $V_{CC} = 3.8V, V_{IN} = 0V$	-150			$\mu A$
$V_{PP}$	Peak-to-Peak Input Voltage		0.15		1.3	V
$V_{CMR}$	Common Mode Input Voltage; NOTE 1, 2		$V_{EE} + 0.5$		$V_{CC} - 0.85$	V

NOTE 1: Common mode voltage is defined as  $V_{IH}$ .

NOTE 2: For single ended applications, the maximum input voltage for CLK0, nCLK0 and CLK1, nCLK1 is  $V_{CC} + 0.3V$ .



**TABLE 3D. LVPECL DC CHARACTERISTICS,  $V_{CC}, V_{CCO} = 2.375V$  TO  $3.8V$ ,  $T_A = -40^{\circ}C$  TO  $85^{\circ}C$**

Symbol	Parameter	Test Conditions	Minimum	Typical	Maximum	Units
$V_{OH}$	Output High Voltage; NOTE 1		$V_{CCO} - 1.4$		$V_{CCO} - 1.0$	V
$V_{OL}$	Output Low Voltage; NOTE 1		$V_{CCO} - 2.0$		$V_{CCO} - 1.7$	V
$V_{SWING}$	Peak-to-Peak Output Voltage Swing		0.6		0.85	V

NOTE 1: Outputs terminated with  $50\Omega$  to  $V_{CCO} - 2V$ .

**TABLE 4. AC CHARACTERISTICS,  $V_{CC} = V_{CCO} = 2.375V$  TO  $3.8V$ ,  $T_A = -40^{\circ}C$  TO  $85^{\circ}C$**

Symbol	Parameter	Test Conditions	Minimum	Typical	Maximum	Units
$f_{MAX}$	Output Frequency				700	MHz
$t_{PD}$	Propagation Delay; NOTE 1	$f \leq 500MHz$		2	2.5	ns
$t_{sk(o)}$	Output Skew; NOTE 2, 4			30	55	ps
$t_{sk(pp)}$	Part-to-Part Skew; NOTE 3, 4			140	340	ps
$f_{jit}$	Buffer Additive Phase Jitter, RMS; refer to Additive Phase Jitter Section			<0.13		ps
$t_R$	Output Rise Time	20% to 80%	200		700	ps
$t_F$	Output Fall Time	20% to 80%	200		700	ps
odc	Output Duty Cycle		47		53	%

All parameters measured at 500MHz unless noted otherwise.

NOTE 1: Measured from the differential input crossing point to the differential output crossing point.

NOTE 2: Defined as skew between outputs at the same supply voltage and with equal load conditions. Measured at the output differential cross points.

NOTE 3: Defined as skew between outputs on different devices operating at the same supply voltages and with equal load conditions. Using the same type of inputs on each device, the outputs are measured at the differential cross points.

NOTE 4: This parameter is defined in accordance with JEDEC Standard 65.



### ADDITIVE PHASE JITTER

The spectral purity in a band at a specific offset from the fundamental compared to the power of the fundamental is called the **dBc Phase Noise**. This value is normally expressed using a Phase noise plot and is most often the specified plot in many applications. Phase noise is defined as the ratio of the noise power present in a 1Hz band at a specified offset from the fundamental frequency to the power value of the fundamental. This ratio is expressed in decibels (dBm) or a ratio of the power in

the 1Hz band to the power in the fundamental. When the required offset is specified, the phase noise is called a **dBc** value, which simply means dBm at a specified offset from the fundamental. By investigating jitter in the frequency domain, we get a better understanding of its effects on the desired application over the entire time record of the signal. It is mathematically possible to calculate an expected bit error rate given a phase noise plot.

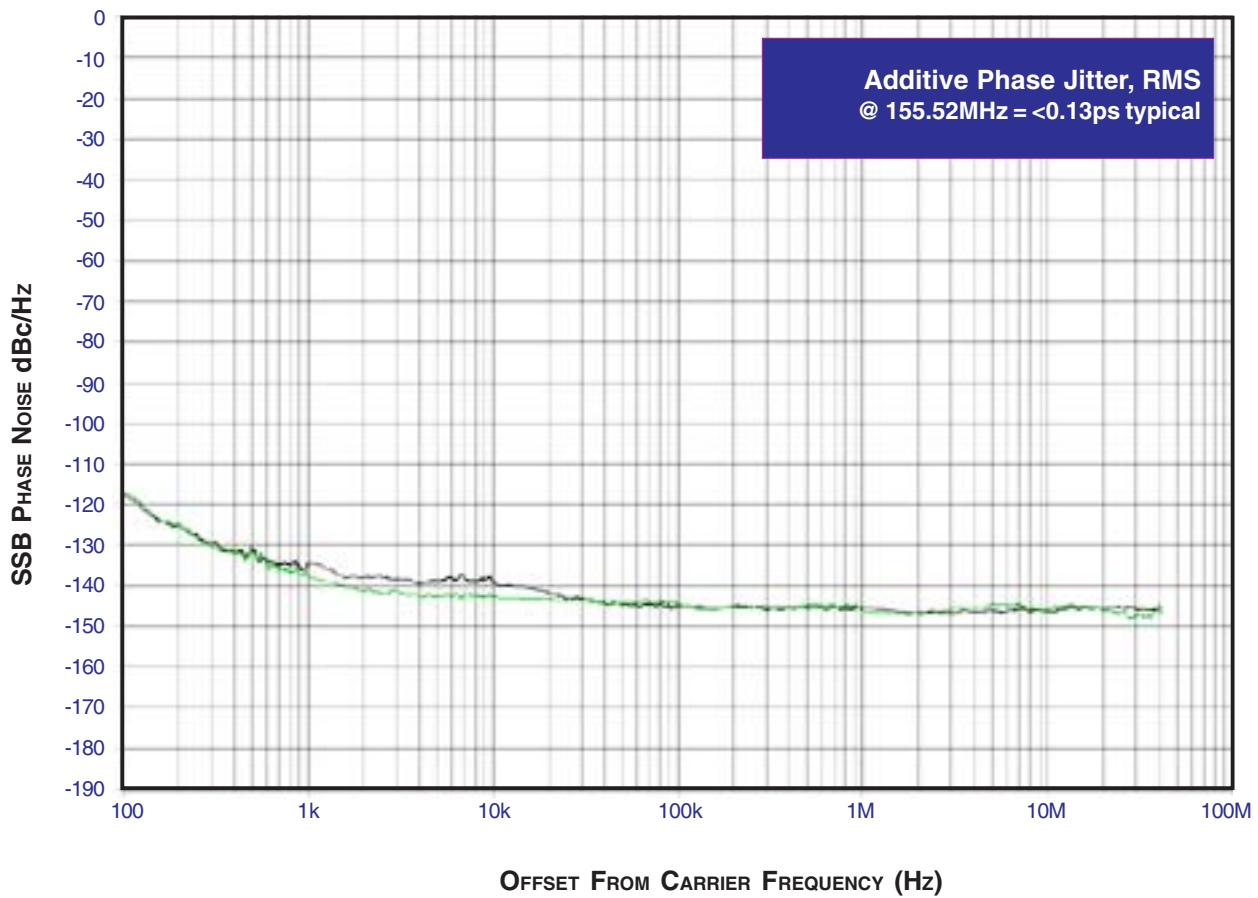

As with most timing specifications, phase noise measurements have issues. The primary issue relates to the limitations of the equipment. Often the noise floor of the equipment is higher than the noise floor of the device. This is illustrated above. The de-

vice meets the noise floor of what is shown, but can actually be lower. The phase noise is dependant on the input source and measurement equipment.



## PARAMETER MEASUREMENT INFORMATION

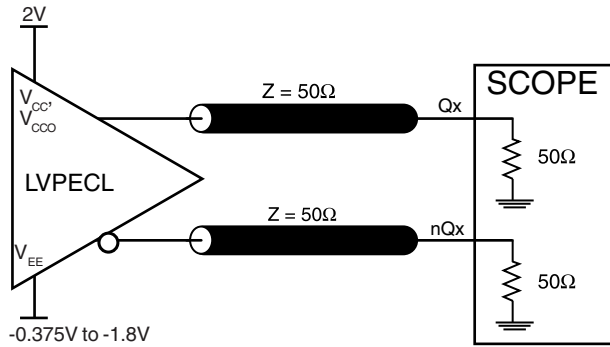

**3.3V OUTPUT LOAD AC TEST CIRCUIT**

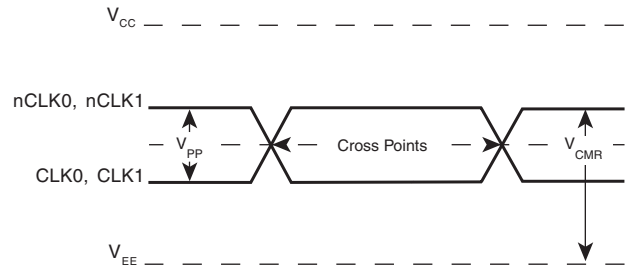

**DIFFERENTIAL INPUT LEVEL**

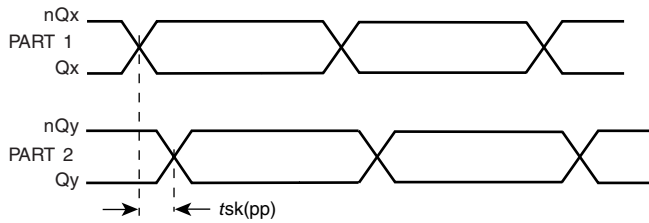

**PART-TO-PART SKEW**

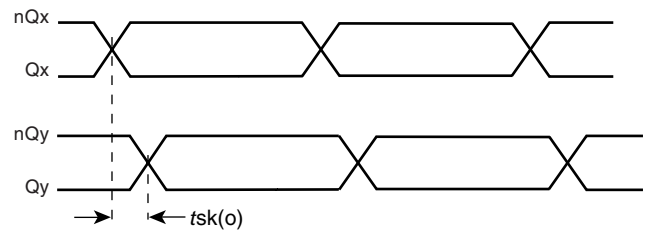

**OUTPUT SKEW**

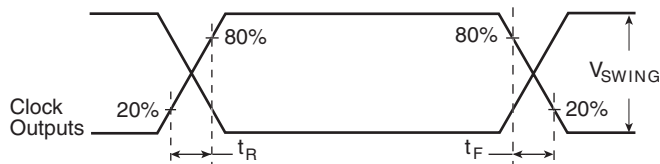

**OUTPUT RISE/FALL TIME**

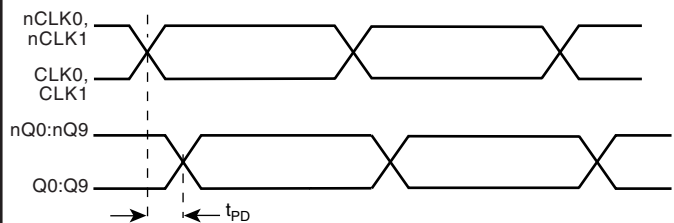

**PROPAGATION DELAY**

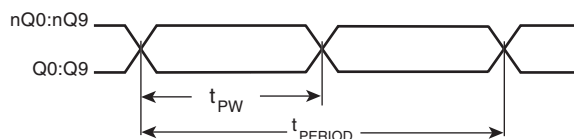

$$\text{odc} = \frac{t_{PW}}{t_{PERIOD}} \times 100\%$$

**OUTPUT DUTY CYCLE/PULSE WIDTH/PERIOD**



## APPLICATION INFORMATION

### WIRING THE DIFFERENTIAL INPUT TO ACCEPT SINGLE ENDED LEVELS

Figure 1 shows how the differential input can be wired to accept single ended levels. The reference voltage  $V_{REF} \approx V_{CC}/2$  is generated by the bias resistors R1, R2 and C1. This bias circuit should be located as close as possible to the input pin.

The ratio of R1 and R2 might need to be adjusted to position the  $V_{REF}$  in the center of the input voltage swing. For example, if the input clock swing is only 2.5V and  $V_{CC} = 3.3V$ ,  $V_{REF}$  should be 1.25V and  $R2/R1 = 0.609$ .

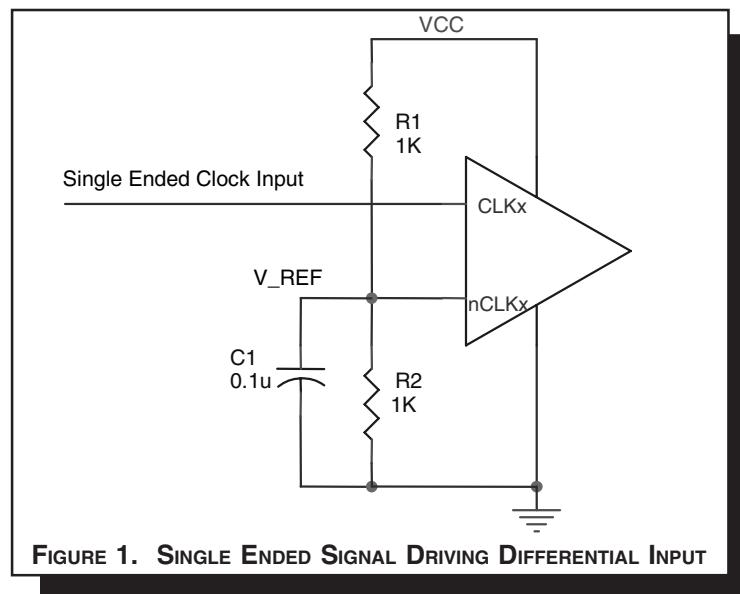

FIGURE 1. SINGLE ENDED SIGNAL DRIVING DIFFERENTIAL INPUT

### RECOMMENDATIONS FOR UNUSED INPUT AND OUTPUT PINS

#### INPUTS:

##### CLK/nCLK INPUT:

For applications not requiring the use of the differential input, both CLK and nCLK can be left floating. Though not required, but for additional protection, a 1kΩ resistor can be tied from CLK to ground.

#### OUTPUTS:

##### LVPECL OUTPUT

All unused LVPECL outputs can be left floating. We recommend that there is no trace attached. Both sides of the differential output pair should either be left floating or terminated.



#### DIFFERENTIAL CLOCK INPUT INTERFACE

The CLK/nCLK accepts LVDS, LVPECL, LVHSTL, SSTL, HCSSL and other differential signals. Both  $V_{SWING}$  and  $V_{OH}$  must meet the  $V_{PP}$  and  $V_{CMR}$  input requirements. Figures 2A to 2E show interface examples for the HiPerClockS CLK/nCLK input driven by the most common driver types. The input interfaces suggested

here are examples only. Please consult with the vendor of the driver component to confirm the driver termination requirements. For example in *Figure 2A*, the input termination applies for ICS HiPerClockS LVHSTL drivers. If you are using an LVHSTL driver from another vendor, use their termination recommendation.

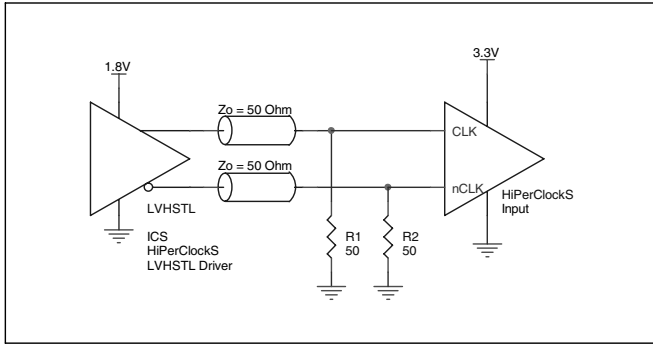

**FIGURE 2A. HiPerClockS CLK/nCLK INPUT DRIVEN BY ICS HiPerClockS LVHSTL DRIVER**

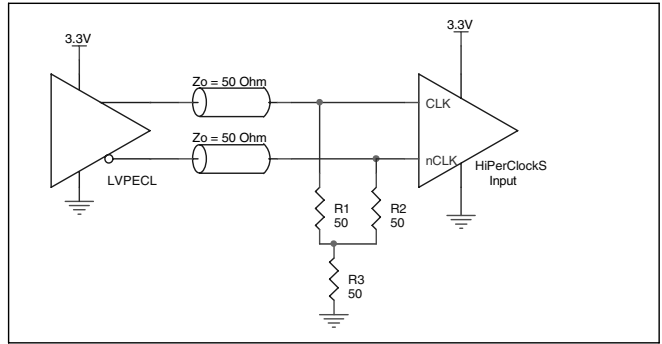

**FIGURE 2B. HiPerClockS CLK/nCLK INPUT DRIVEN BY 3.3V LVPECL DRIVER**

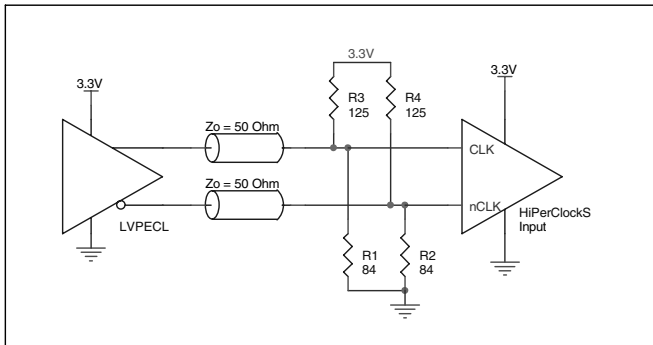

**FIGURE 2C. HiPerClockS CLK/nCLK INPUT DRIVEN BY 3.3V LVPECL DRIVER**

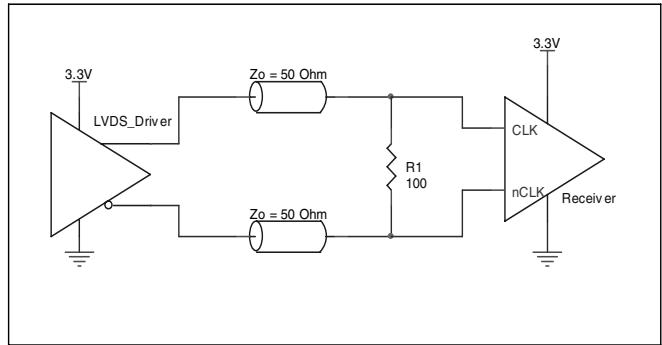

**FIGURE 2D. HiPerClockS CLK/nCLK INPUT DRIVEN BY 3.3V LVDS DRIVER**

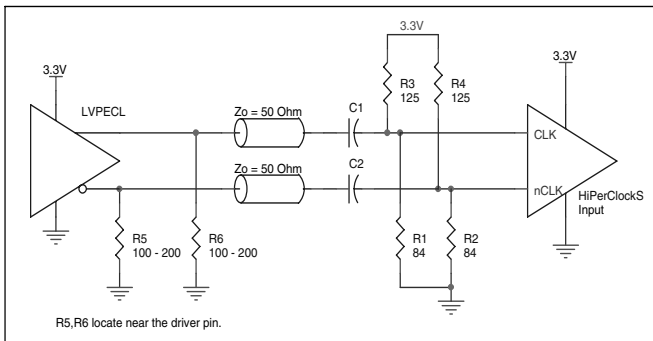

**FIGURE 2E. HiPerClockS CLK/nCLK INPUT DRIVEN BY 3.3V LVPECL DRIVER WITH AC COUPLE**





### TERMINATION FOR LVPECL OUTPUTS

The clock layout topology shown below is a typical termination for LVPECL outputs. The two different layouts mentioned are recommended only as guidelines.

FOUT and nFOUT are low impedance follower outputs that generate ECL/LVPECL compatible outputs. Therefore, terminating resistors (DC current path to ground) or current sources must be used for functionality. These outputs are designed to drive 50Ω transmission lines. Matched imped-

ance techniques should be used to maximize operating frequency and minimize signal distortion. *Figures 3A and 3B* show two different layouts which are recommended only as guidelines. Other suitable clock layouts may exist and it would be recommended that the board designers simulate to guarantee compatibility across all printed circuit and clock component process variations.

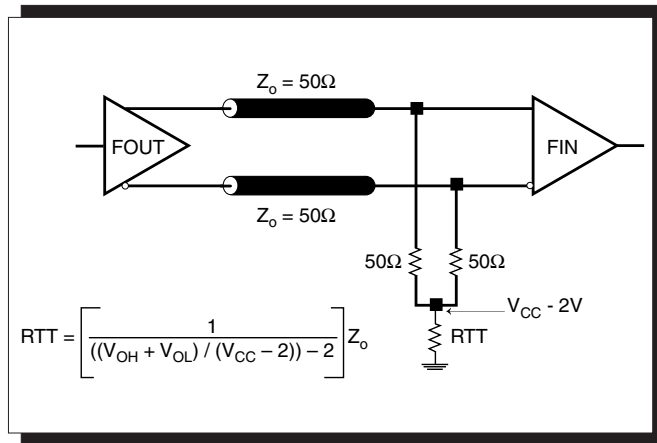

FIGURE 3A. LVPECL OUTPUT TERMINATION

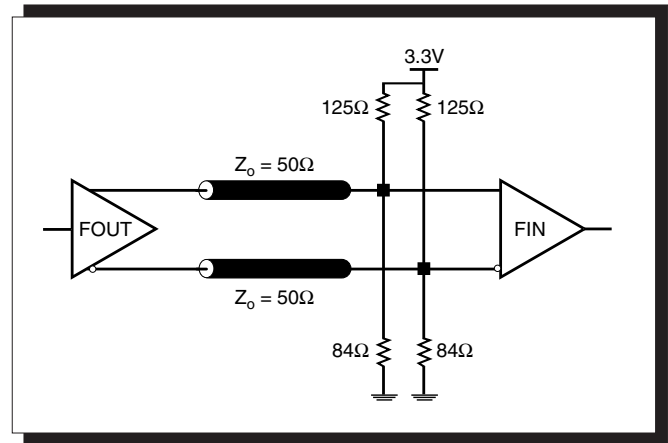

FIGURE 3B. LVPECL OUTPUT TERMINATION



## POWER CONSIDERATIONS

This section provides information on power dissipation and junction temperature for the ICS85310I-01. Equations and example calculations are also provided.

### 1. Power Dissipation.

The total power dissipation for the ICS85310I-01 is the sum of the core power plus the power dissipated in the load(s). The following is the power dissipation for  $V_{CC} = 3.8V$ , which gives worst case results.

**NOTE:** Please refer to Section 3 for details on calculating power dissipated in the load.

- Power (core)<sub>MAX</sub> =  $V_{CC\_MAX} * I_{EE\_MAX} = 3.8V * 120mA = 456mW$
- Power (outputs)<sub>MAX</sub> = **30.2mW/Loaded Output pair**  
If all outputs are loaded, the total power is  $10 * 30.2mW = 302mW$

**Total Power**<sub>MAX</sub> (3.8V, with all outputs switching) =  $456mW + 302mW = 758mW$

### 2. Junction Temperature.

Junction temperature,  $T_j$ , is the temperature at the junction of the bond wire and bond pad and directly affects the reliability of the device. The maximum recommended junction temperature for HiPerClockS™ devices is 125°C.

The equation for  $T_j$  is as follows:  $T_j = \theta_{JA} * Pd\_total + T_A$

$T_j$  = Junction Temperature

$\theta_{JA}$  = Junction-to-Ambient Thermal Resistance

$Pd\_total$  = Total Device Power Dissipation (example calculation is in section 1 above)

$T_A$  = Ambient Temperature

In order to calculate junction temperature, the appropriate junction-to-ambient thermal resistance  $\theta_{JA}$  must be used. Assuming a moderate air flow of 200 linear feet per minute and a multi-layer board, the appropriate value is 42.1°C/W per Table 5 below.

Therefore,  $T_j$  for an ambient temperature of 85°C with all outputs switching is:

$85^\circ C + 0.758W * 42.1^\circ C/W = 117^\circ C$ . This is below the limit of 125°C.

This calculation is only an example.  $T_j$  will obviously vary depending on the number of loaded outputs, supply voltage, air flow, and the type of board (single layer or multi-layer).

**TABLE 5. THERMAL RESISTANCE  $\theta_{JA}$  FOR 32-PIN LQFP, FORCED CONVECTION**

	$\theta_{JA}$ by Velocity (Linear Feet per Minute)		
	0	200	500
Single-Layer PCB, JEDEC Standard Test Boards	67.8°C/W	55.9°C/W	50.1°C/W
Multi-Layer PCB, JEDEC Standard Test Boards	47.9°C/W	42.1°C/W	39.4°C/W

**NOTE:** Most modern PCB designs use multi-layered boards. The data in the second row pertains to most designs.



3. Calculations and Equations.

LVPECL output driver circuit and termination are shown in Figure 4.

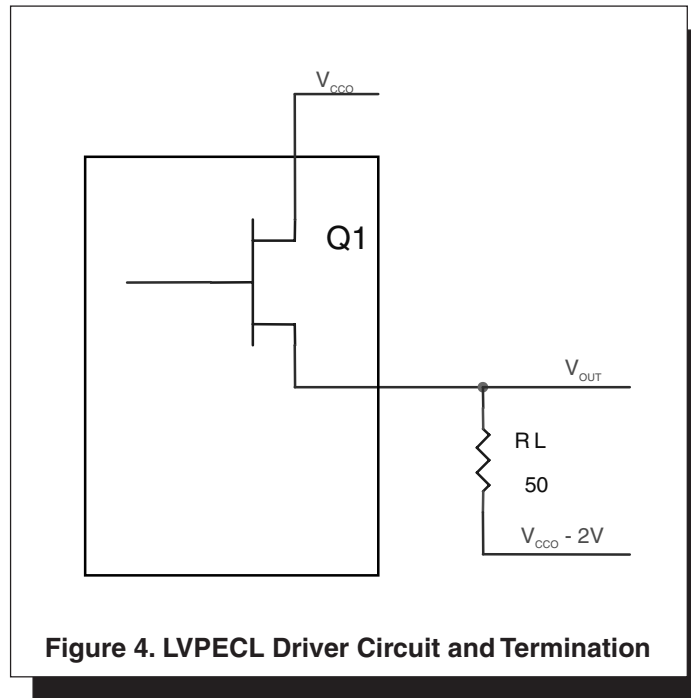

**Figure 4. LVPECL Driver Circuit and Termination**

To calculate worst case power dissipation into the load, use the following equations which assume a 50Ω load, and a termination voltage of  $V_{CCO} - 2V$ .

- For logic high,  $V_{OUT} = V_{OH\_MAX} = V_{CCO\_MAX} - 1.0V$

$$(V_{CCO\_MAX} - V_{OH\_MAX}) = 1.0V$$

- For logic low,  $V_{OUT} = V_{OL\_MAX} = V_{CCO\_MAX} - 1.7V$

$$(V_{CCO\_MAX} - V_{OL\_MAX}) = 1.7V$$

$Pd\_H$  is power dissipation when the output drives high.

$Pd\_L$  is the power dissipation when the output drives low.

$$Pd\_H = [(V_{OH\_MAX} - (V_{CCO\_MAX} - 2V))/R_L] * (V_{CCO\_MAX} - V_{OH\_MAX}) = [(2V - (V_{CCO\_MAX} - V_{OH\_MAX}))/R_L] * (V_{CCO\_MAX} - V_{OH\_MAX}) = [(2V - 1V)/50\Omega] * 1V = 20.0mW$$

$$Pd\_L = [(V_{OL\_MAX} - (V_{CCO\_MAX} - 2V))/R_L] * (V_{CCO\_MAX} - V_{OL\_MAX}) = [(2V - (V_{CCO\_MAX} - V_{OL\_MAX}))/R_L] * (V_{CCO\_MAX} - V_{OL\_MAX}) = [(2V - 1.7V)/50\Omega] * 1.7V = 10.2mW$$

Total Power Dissipation per output pair =  $Pd\_H + Pd\_L = 30.2mW$



## RELIABILITY INFORMATION

TABLE 6.  $\theta_{JA}$  VS. AIR FLOW TABLE FOR 32 LEAD LQFP

$\theta_{JA}$ by Velocity (Linear Feet per Minute)			
	0	200	500
Single-Layer PCB, JEDEC Standard Test Boards	67.8°C/W	55.9°C/W	50.1°C/W
Multi-Layer PCB, JEDEC Standard Test Boards	47.9°C/W	42.1°C/W	39.4°C/W

**NOTE:** Most modern PCB designs use multi-layered boards. The data in the second row pertains to most designs.

### TRANSISTOR COUNT

The transistor count for ICS85310I-01 is: 1034

Pin compatible with MC100LVEP111



**PACKAGE OUTLINE - Y SUFFIX FOR 32 LEAD LQFP**

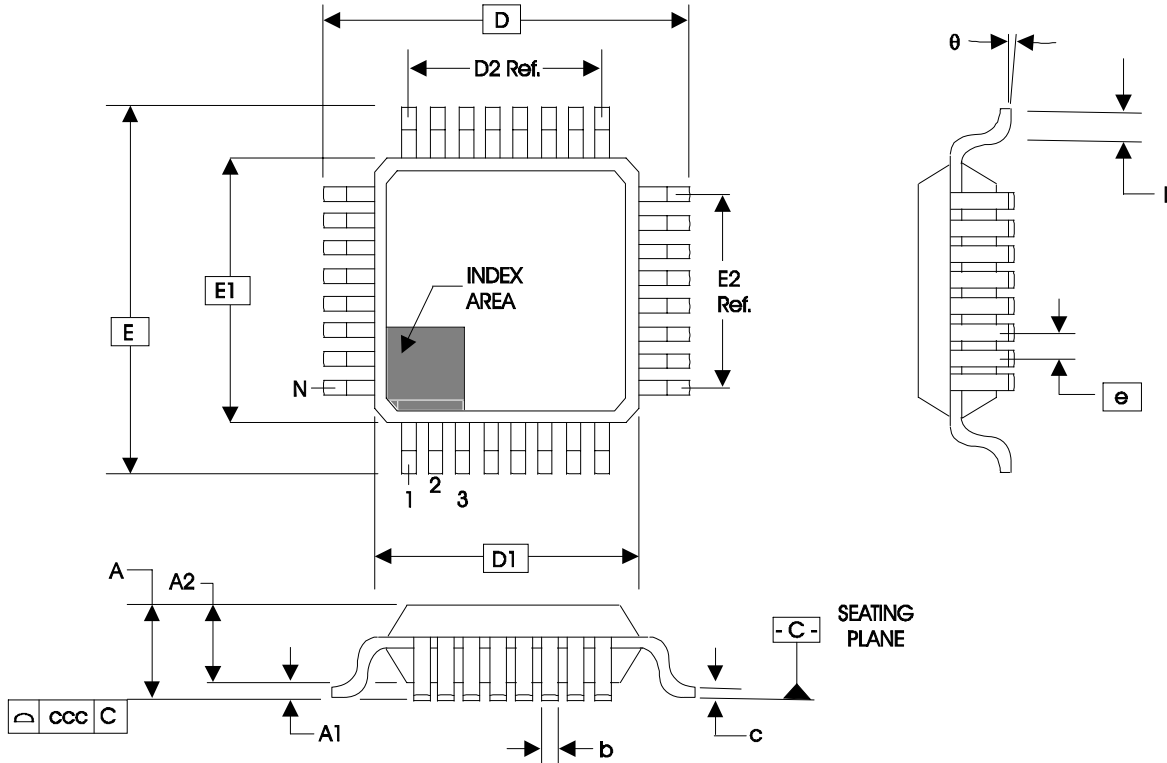

**TABLE 7. PACKAGE DIMENSIONS**

JEDEC VARIATION ALL DIMENSIONS IN MILLIMETERS			
SYMBOL	BBA		
	MINIMUM	NOMINAL	MAXIMUM
N	32		
A	--	--	1.60
A1	0.05	--	0.15
A2	1.35	1.40	1.45
b	0.30	0.37	0.45
c	0.09	--	0.20
D	9.00 BASIC		
D1	7.00 BASIC		
D2	5.60 Ref.		
E	9.00 BASIC		
E1	7.00 BASIC		
E2	5.60 Ref.		
e	0.80 BASIC		
L	0.45	0.60	0.75
θ	0°	--	7°
ccc	--	--	0.10

Reference Document: JEDEC Publication 95, MS-026



Integrated  
Circuit  
Systems, Inc.

**ICS85310I-01**  
Low SKEW, 1-TO-10  
DIFFERENTIAL-TO-2.5V/3.3V ECL/LVPECL FANOUT BUFFER

**TABLE 8. ORDERING INFORMATION**

Part/Order Number	Marking	Package	Shipping Packaging	Temperature
ICS85310AYI-01	ICS85310AYI01	32 lead LQFP	tray	-40°C to 85°C
ICS85310AYI-01T	ICS85310AYI01	32 lead LQFP	1000 tape & reel	-40°C to 85°C
ICS85310AYI-01LF	ICS5310AI01L	32 lead "Lead Free" LQFP	tray	-40°C to 85°C
ICS85310AYI-01LFT	ICS5310AI01L	32 lead "Lead Free" LQFP	1000 tape & reel	-40°C to 85°C
ICS85310AYI-01LN	ICS5310AI01N	32 lead (Lead Free/Annealed) LQFP	tray	-40°C to 85°C
ICS85310AYI-01LNT	ICS5310AI01N	32 lead (Lead Free/Annealed) LQFP	1000 tape & reel	-40°C to 85°C

NOTE: Parts that are ordered with an "LF" suffix to the part number are the Pb-Free configuration and are RoHS compliant.

The aforementioned trademark, HiPerClockS is a trademark of Integrated Circuit Systems, Inc. or its subsidiaries in the United States and/or other countries. While the information presented herein has been checked for both accuracy and reliability, Integrated Circuit Systems, Incorporated (ICS) assumes no responsibility for either its use or for infringement of any patents or other rights of third parties, which would result from its use. No other circuits, patents, or licenses are implied. This product is intended for use in normal commercial and industrial applications. Any other applications such as those requiring high reliability, or other extraordinary environmental requirements are not recommended without additional processing by ICS. ICS reserves the right to change any circuitry or specifications without notice. ICS does not authorize or warrant any ICS product for use in life support devices or critical medical instruments.



DIFFERENTIAL-TO-2.5V/3.3V ECL/LVPECL FANOUT BUFFER

REVISION HISTORY SHEET				
Rev	Table	Page	Description of Change	Date
B	T4	4	AC Characteristics table - $t_{PD}$ row, revised value from 2.25ns Max. to 2.5ns Max.	4/29/02
B		8	Added Termination for LVPECL Outputs.	5/29/02
C	T3D	4	Added LVPECL DC Characteristics table. Changed part number from ICS85310-01 to ICS85310I-01 in title and all subsequent areas throughout the datasheet.	7/26/02
D	T3A	3 7	Power Supply table - increased max. value for $I_{EE}$ to 120mA from 30mA max. Power Considerations have re-adjusted to the increased $I_{EE}$ value.	10/22/02
E	T2	2 3 6 7 12	Pin Characteristics - changed $C_{IN}$ 4pF max. to 4pF typical. Absolute Maximum Ratings - updated Outputs. Updated Single Ended Signal Driving Differential Input Drawing and LVPECL Output Termination Drawings. Added Differential Clock Input Interface section. Added Lead Free/Annealed part number.	6/14/04
F	T8	1 5 13	Features Section - added Additive Phase Jitter bullet. Added Additive Phase Jitter Section. Ordering Information Table - added Lead-Free Note.	6/22/05
F	T8	7 14	Added <i>Recommendations for Unused Input and Output Pins</i> . Ordering Information Table - added lead-free part number and marking.	1/16/06