

## GaAs MMIC X4 ACTIVE FREQUENCY MULTIPLIER, 54 - 64 GHz OUTPUT

### Typical Applications

This HMC-XDH158 is ideal for:

- Short-Haul / High Capacity Radios
- Point-to-Point Radio
- Test & Measurement Equipment
- SATCOM
- Military and Secure Communications

### Features

- Output Power: -6 dBm
- Wide Input Power Range: 0 to +5 dBm
- High Fo Isolation: 30 dB
- Low Conversion Loss: 8 dB
- Die Size: 1.8 x 0.8 x 0.1 mm

### Functional Diagram

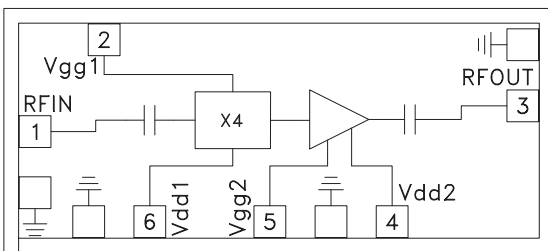

### General Description

The HMC-XDH158 is a monolithic X4 Active Frequency Multiplier which utilizes GaAs High Electron Mobility Transistor (HEMT) technology and exhibits low conversion loss and high Fo isolation. This wideband multiplier is ideal for use in LO multiplier chains for high capacity and SATCOM radios yielding reduced parts count vs. traditional approaches. All bond pads and the die backside are Ti/Au metallized and the HEMT devices are fully passivated for reliable operation. The HMC-XDH158 X4 Active Frequency Multiplier MMIC is compatible with conventional die attach methods, as well as thermocompression and thermosonic wire bonding, making it ideal for MCM and hybrid microcircuit applications. All data shown herein is measured with the chip in a 50 Ohm environment and contacted with RF probes.

### Electrical Specifications\*

$T_A = 25\text{ }^\circ\text{C}$ ,  $V_{dd1} = 1.5\text{V}$ ,  $V_{dd2} = 4\text{V}$ ,  $V_{gg1} = -0.2\text{V}$ ,  $V_{gg2} = -0.3\text{V}$ , +2 dBm Drive Level

Parameter	Min.	Typ.	Max.	Units
Frequency Range Input		14 - 16		GHz
Frequency Range Output		56 - 64		GHz
Output Power		-6		dBm
Conversion Loss		8	14	dB
Fo Isolation with respect to output		36		dB
2Fo Isolation with respect to output		54		dB
Supply Current	Idd1	14		mA
	Idd2	115		mA

\*Unless otherwise indicated, all measurements are from probed die

**GaAs MMIC X4 ACTIVE FREQUENCY MULTIPLIER, 54 - 64 GHz OUTPUT**

**x4 Conversion Loss vs. Frequency**

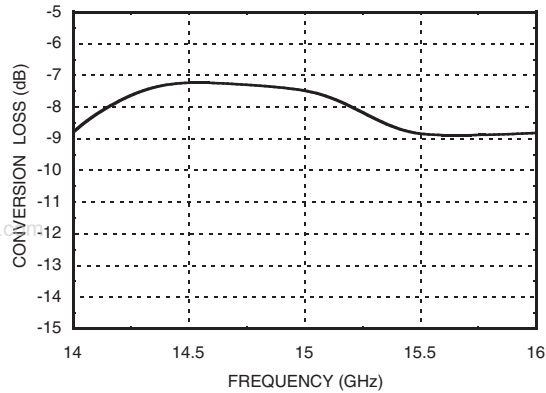

**Output Power vs. Frequency**

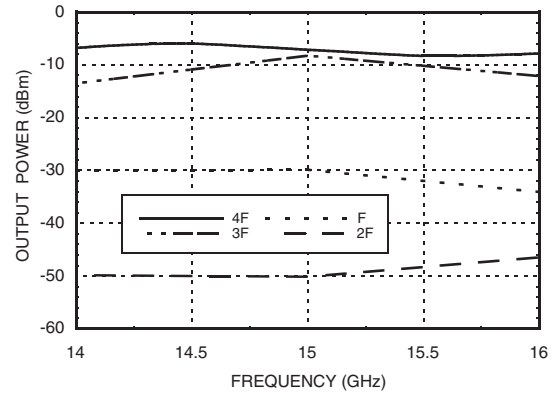

## GaAs MMIC X4 ACTIVE FREQUENCY MULTIPLIER, 54 - 64 GHz OUTPUT

### Absolute Maximum Ratings

RF Input Level	+7 dBm
Supply Voltage (Vdd1, Vdd2)	+5 Vdc
Gate Voltage (Vgg1, Vgg2)	-1 to 0.3 Vdc
Channel Temperature	180 °C
Storage Temperature	-65 to +150 °C
Operating Temperature	-55 to +85 °C



ELECTROSTATIC SENSITIVE DEVICE  
OBSERVE HANDLING PRECAUTIONS

### Outline Drawing

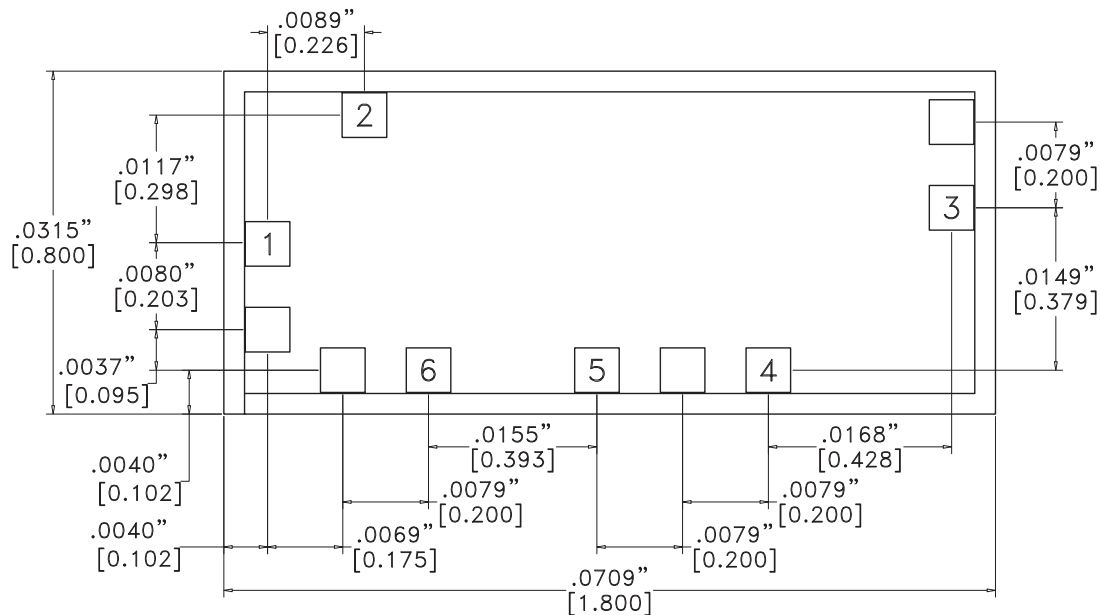

### Die Packaging Information <sup>[1]</sup>

Standard	Alternate
WP - 8	[2]

[1] Refer to the "Packaging Information" section for die packaging dimensions.



[2] For alternate packaging information contact Hittite Microwave Corporation.

#### NOTES:

- ALL DIMENSIONS ARE IN INCHES [MM].
- TYPICAL BOND PAD IS .004" SQUARE.
- BACKSIDE METALLIZATION: GOLD.
- BACKSIDE METAL IS GROUND.
- BOND PAD METALLIZATION: GOLD.
- CONNECTION NOT REQUIRED FOR UNLABELED BOND PADS.
- OVERALL DIE SIZE ±.002"

## GaAs MMIC X4 ACTIVE FREQUENCY MULTIPLIER, 54 - 64 GHz OUTPUT

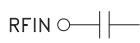
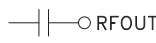
### Pad Descriptions

Pad Number	Function	Description	Interface Schematic
1	RFIN	This pad is AC coupled and matched to 50 Ohms.	RFIN 
4, 6	Vdd1, Vdd2	Power Supply for amplifier. See Assembly Drawing for required external components.	
3	RFOUT	This pad is AC coupled and matched to 50 Ohms.	 RFOUT
2,5	Vgg1, Vgg2	Gate control for amplifier. Please follow "MMIC Amplifier Biasing Procedure" Application Note. See Assembly Drawing for required external components.	
Die Bottom	GND	Die bottom must be connected to RF/DC ground.	 GND

**GaAs MMIC X4 ACTIVE FREQUENCY MULTIPLIER, 54 - 64 GHz OUTPUT**

**Assembly Diagram**

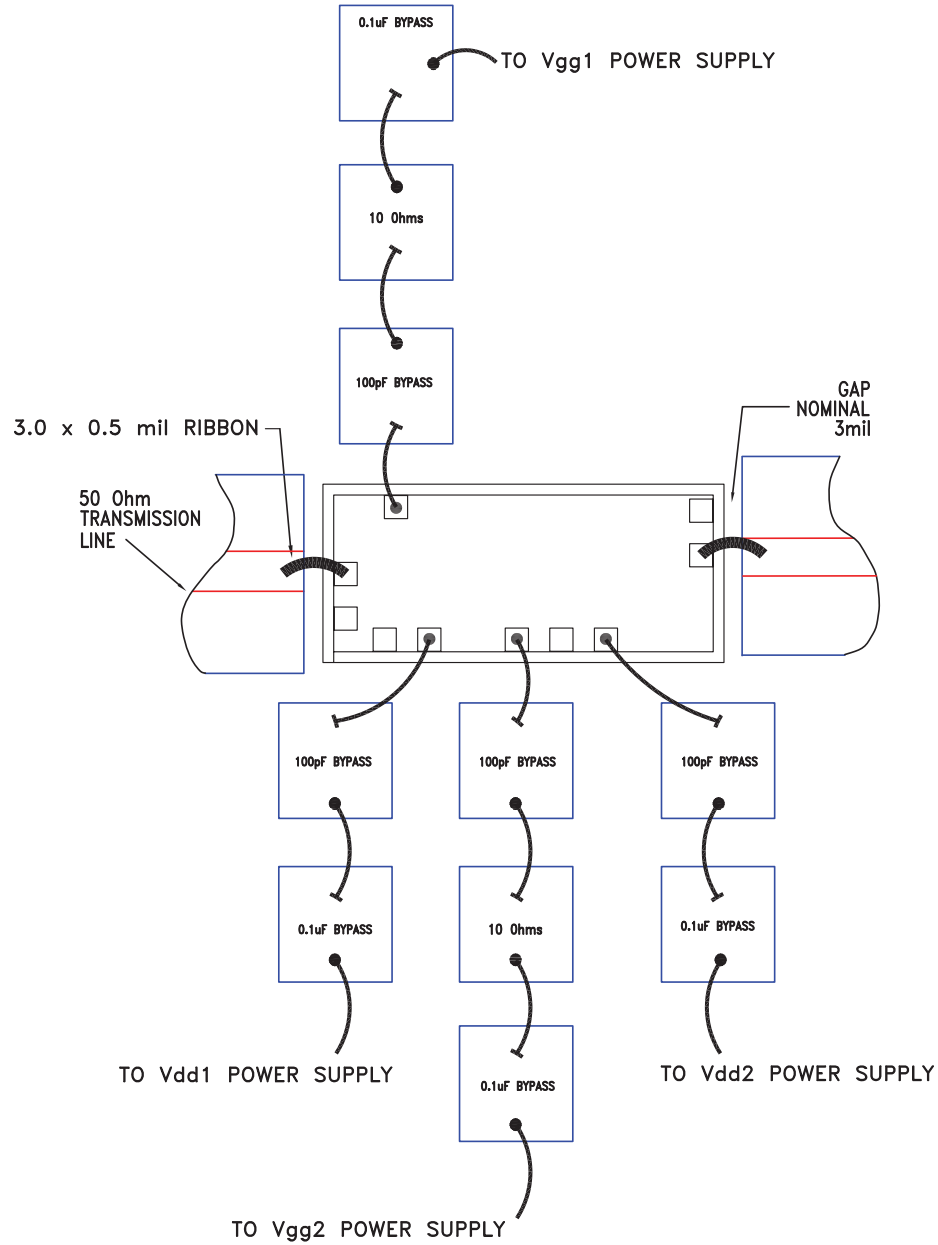

**GaAs MMIC X4 ACTIVE FREQUENCY MULTIPLIER, 54 - 64 GHz OUTPUT**

**Mounting & Bonding Techniques for Millimeterwave GaAs MMICs**

The die should be attached directly to the ground plane eutectically or with conductive epoxy (see HMC general Handling, Mounting, Bonding Note).

50 Ohm Microstrip transmission lines on 0.127mm (5 mil) thick alumina thin film substrates are recommended for bringing RF to and from the chip (Figure 1). If 0.254mm (10 mil) thick alumina thin film substrates must be used, the die should be raised 0.150mm (6 mils) so that the surface of the die is coplanar with the surface of the substrate. One way to accomplish this is to attach the 0.102mm (4 mil) thick die to a 0.150mm (6 mil) thick molybdenum heat spreader (moly-tab) which is then attached to the ground plane (Figure 2).

Microstrip substrates should be placed as close to the die as possible in order to minimize bond wire length. Typical die-to-substrate spacing is 0.076mm to 0.152 mm (3 to 6 mils).

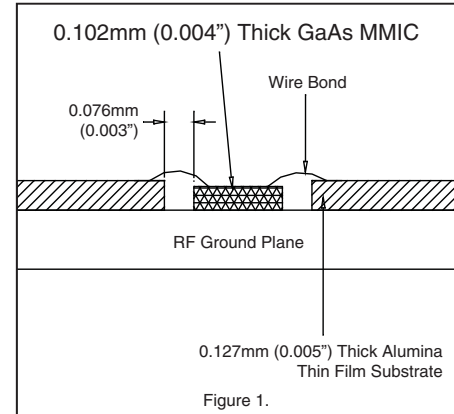

**Handling Precautions**

Follow these precautions to avoid permanent damage.

**Storage:** All bare die are placed in either Waffle or Gel based ESD protective containers, and then sealed in an ESD protective bag for shipment. Once the sealed ESD protective bag has been opened, all die should be stored in a dry nitrogen environment.

**Cleanliness:** Handle the chips in a clean environment. DO NOT attempt to clean the chip using liquid cleaning systems.

**Static Sensitivity:** Follow ESD precautions to protect against ESD strikes.

**Transients:** Suppress instrument and bias supply transients while bias is applied. Use shielded signal and bias cables to minimize inductive pick-up.

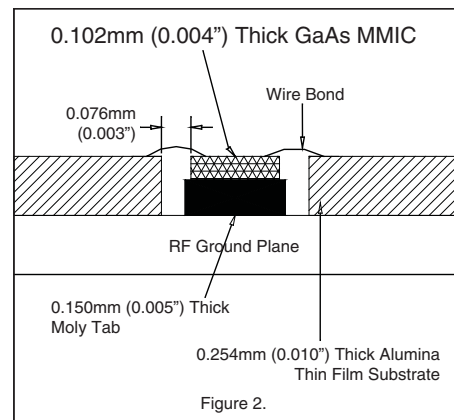

**General Handling:** Handle the chip along the edges with a vacuum collet or with a sharp pair of bent tweezers. The surface of the chip has fragile air bridges and should not be touched with vacuum collet, tweezers, or fingers.

**Mounting**

The chip is back-metallized and can be die mounted with AuSn eutectic preforms or with electrically conductive epoxy. The mounting surface should be clean and flat.

**Eutectic Die Attach:** A 80/20 gold tin preform is recommended with a work surface temperature of 255 °C and a tool temperature of 265 °C. When hot 90/10 nitrogen/hydrogen gas is applied, tool tip temperature should be 290 °C. DO NOT expose the chip to a temperature greater than 320 °C for more than 20 seconds. No more than 3 seconds of scrubbing should be required for attachment.

**Epoxy Die Attach:** Apply a minimum amount of epoxy to the mounting surface so that a thin epoxy fillet is observed around the perimeter of the chip once it is placed into position. Cure epoxy per the manufacturer's schedule.

**Wire Bonding**

RF bonds made with 0.003" x 0.0005" ribbon are recommended. These bonds should be thermosonically bonded with a force of 40-60 grams. DC bonds of 0.001" (0.025 mm) diameter, thermosonically bonded, are recommended. Ball bonds should be made with a force of 40-50 grams and wedge bonds at 18-22 grams. All bonds should be made with a nominal stage temperature of 150 °C. A minimum amount of ultrasonic energy should be applied to achieve reliable bonds. All bonds should be as short as possible, less than 12 mils (0.31 mm).