

Description

The μPD8035HL and the μPD8048H make up the μPD8048H family of single-chip 8-bit microcomputers. The processors in this family differ only in their internal program memory options: the μPD8048H with 1K × 8 bytes of mask ROM and the μPD8035HL with external memory.

The NEC μPD8035HL and μPD8048H are single component, 8-bit, parallel microprocessors using n-channel silicon gate MOS technology. The μPD8048H family of components functions efficiently in control as well as in arithmetic applications. Standard logic function implementation is facilitated by the large variety of branch and table look-up instructions.

The μPD8035HL/48H instruction set comprises 1 and 2 byte instructions with over 70% of them single-byte. Execution requires only 1 or 2 cycles per instruction and over 50% are single-cycle instructions.

The functions of the μPD8048H series of microprocessors can easily be expanded using standard 8080A/8085A peripherals and memories.

The μPD8048H contains the following functions usually found in external peripheral devices: 1024 × 8 bits of ROM program memory; 64 × 8 bits of RAM data memory; 27 I/O lines; an 8-bit interval timer/event counter; oscillator and clock circuitry.

The μPD8035HL is intended for applications using external program memory only. It contains all the features of the μPD8048H except the 1024 × 8-bit internal ROM. The external program memory can be implemented using standard 8080A/8085A memory products.

Features

- Fully compatible with industry standard 8048/8748/8035
- 2.5 μs cycle time: all instructions 1 or 2 bytes
- Interval timer/event counter
- 64 × 8-byte RAM data memory
- External and timer interrupts
- 96 instructions: 70% single byte
- 27 I/O lines
- Internal clock generator
- 8 level stack
- Compatible with 8080A/8085A peripherals
- HMOS silicon gate technology
- Single +5V power supply

Ordering Information

Part Number	Package Type	Max Frequency of Operation
μPD8035HLC	40-pin plastic DIP	6 MHz
μPD8048HC	40-pin plastic DIP	6 MHz

Pin Configuration

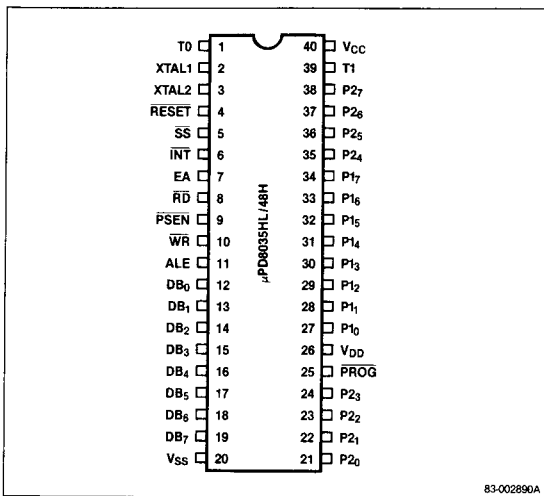

83-002890A



Pin Identification

No.	Symbol	Function
1	T0	Test 0 input/output
2	XTAL1	Crystal 1 input
3	XTAL2	Crystal 2 input
4	RESET	Reset input
5	SS	Single step input
6	INT	Interrupt input
7	EA	External access input
8	RD	Read output
9	PSEN	Program store enable output
10	WR	Write output
11	ALE	Address latch enable output
12-19	DB ₀ -DB ₇	Bidirectional data bus
20	Vss	Ground
21-24, 35-38	P ₂₀ -P ₂₇	Quasi-bidirectional Port 2
25	PROG	Program output

Pin Identification (cont)

No.	Symbol	Function
26	V _{DD}	RAM power supply
27-34	P ₁₀ -P ₁₇	Quasi-bidirectional Port 1
39	T1	Test 1 input
40	V _{CC}	Primary power supply

Pin Functions**XTAL 1 (Crystal 1)**

XTAL1 is one side of the crystal, LC, or external frequency source (non-TTL-compatible V_{IH}).

XTAL 2 (Crystal 2)

XTAL2 is the other side of the crystal or frequency source.

T0 (Test 0)

T0 is the testable input using conditional transfer functions JT0 and JNT0. The internal state clock (CLK) is available to T0 using the ENT0 CLK instruction. T0 can also be used during programming as a testable flag.

T1 (Test 1)

T1 is the testable input using conditional transfer functions JT1 and JNT1. T1 can be made the counter/timer input using the STRT CNT instruction.

RESET (Reset)

An active low on $\overline{\text{RESET}}$ initializes the processor. $\overline{\text{RESET}}$ is also used for PROM programming verification and power-down (non-TTL compatible V_{IH}).

SS (Single Step)

An active low on $\overline{\text{SS}}$, together with ALE, causes the processor to execute the program one step at a time.

INT (Interrupt)

An active low on $\overline{\text{INT}}$ starts an interrupt if interrupts are enabled. A reset disables an interrupt. $\overline{\text{INT}}$ can be tested with the JN1 instruction and, depending on the results, a jump to the specified address can occur.

EA (External Access)

An active high on EA disables internal program memory and fetches and accesses external program memory. EA is used for system testing and debugging.

RD (Read)

$\overline{\text{RD}}$ will pulse low when the processor performs a bus read. An active low on $\overline{\text{RD}}$ enables data onto the processor bus from a peripheral device and functions as a read strobe for external data memory.

WR (Write)

$\overline{\text{WR}}$ will pulse low when the processor performs a bus write. $\overline{\text{WR}}$ can also function as a write strobe for external data memory.

PSEN (Program Store Enable)

$\overline{\text{PSEN}}$ becomes active only during an external memory fetch. (Active low).

ALE (Address Latch Enable)

ALE occurs at each cycle. ALE can also be used as a clock output. The falling edge of ALE addresses external data memory or external program memory.

DB₀-DB₇ (Data Bus)

DB₀-DB₇ is a bidirectional port. Synchronous reads and writes can be performed on this port using $\overline{\text{RD}}$ and $\overline{\text{WR}}$ strobes. The contents of the DB₀-DB₇ bus can be latched in a static mode.

During an external memory fetch, DB₀-DB₇ output the low-order eight bits of the memory address. $\overline{\text{PSEN}}$ fetches the instruction. DB₀-DB₇ also output the address of an external data memory fetch. The addressed data is controlled by ALE, RD, and WR.

P₁₀-P₁₇ (Port 1)

P₁₀-P₁₇ is an 8-bit quasi-bidirectional port.

P₂₀-P₂₇ (Port 2)

P₂₀-P₂₇ is an 8-bit quasi-bidirectional port. P₂₀-P₂₃ output the high-order four bits of the address during an external program memory fetch. P₂₀-P₂₃ also function as a 4-bit I/O bus for the μPD82C43 I/O port expander.

PROG (Program Pulse)

$\overline{\text{PROG}}$ is used as an output pulse during a fetch when interfacing with the μPD82C43 I/O port expander.

V_{CC} (Primary Power Supply)

V_{CC} is the primary power supply. V_{CC} is +5V during normal operation.

V_{DD} (RAM Power Supply)

V_{DD} must be set to +5V for normal operation. V_{DD} supplies power to the internal RAM during standby mode.

V_{SS} (Ground)

V_{SS} is ground potential.

Block Diagram

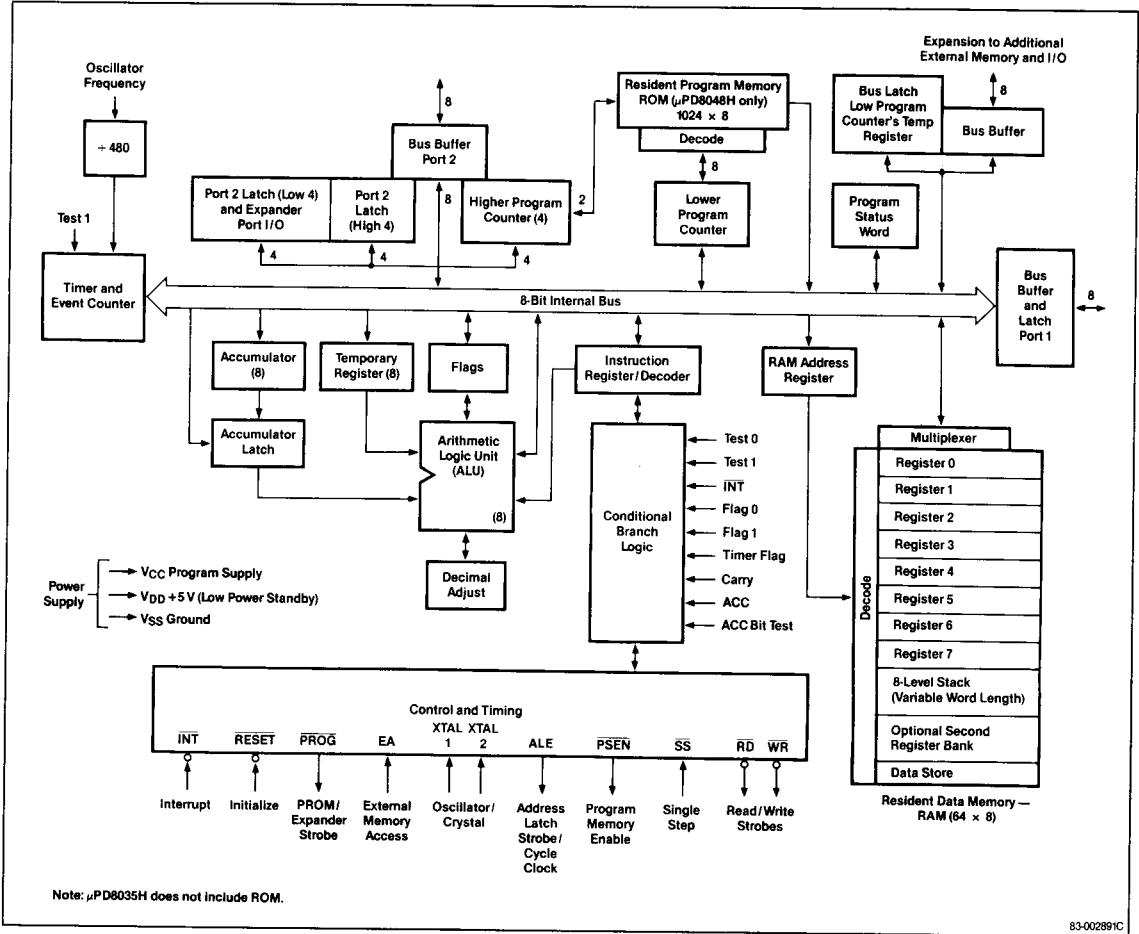

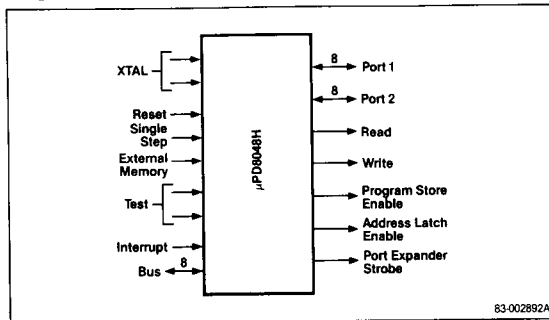
Logic Symbol**Absolute Maximum Ratings** $T_A = 25^\circ\text{C}$

Operating temperature, T_{OPT}	0°C to $+70^\circ\text{C}$
Storage temperature, T_{STG}	-65°C to $+150^\circ\text{C}$
Voltage on any pin, $V_{I/O}$	-0.5 V to $+7\text{ V}$ (Note 1)
Power dissipation, P_D	1.5 W

Note:

(1) With respect to ground.

Comment: Exposing the device to stresses above those listed in Absolute Maximum Ratings could cause permanent damage. The device is not meant to be operated under conditions outside the limits described in the operational sections of the specification. Exposure to absolute maximum rating conditions for extended periods may affect device reliability.

DC Characteristics $T_A = 0^\circ\text{C}$ to $+70^\circ\text{C}$, $V_{\text{CC}} = V_{\text{DD}} = +5\text{ V} \pm 10\%$, $V_{\text{SS}} = 0\text{ V}$

Parameter	Symbol	Limits			Unit	Test Conditions
		Min	Typ	Max		
Input low voltage (All except XTAL1, XTAL2)	V_{IL}	-0.5		0.8	V	
Input low voltage (RESET, X1, X2)	V_{IL1}	-0.5		0.8	V	
Input high voltage (All except XTAL1, XTAL2, RESET)	V_{IH}	2.0		V_{CC}	V	
Input high voltage (XTAL1, XTAL2, RESET)	V_{IH1}	3.8		V_{CC}	V	
Output low voltage (bus)	V_{OL}		0.45		V	$I_{\text{OL}} = 2.0\text{ mA}$
Output low voltage (RD, WR, PSEN, ALE)	V_{OL1}		0.45		V	$I_{\text{OL}} = 2.0\text{ mA}$
Output low voltage (PROG)	V_{OL2}		0.45		V	$I_{\text{OL}} = 2.0\text{ mA}$

DC Characteristics (cont) $T_A = 0^\circ\text{C}$ to $+70^\circ\text{C}$, $V_{\text{CC}} = V_{\text{DD}} = +5\text{ V} \pm 10\%$, $V_{\text{SS}} = 0\text{ V}$

Parameter	Symbol	Limits			Unit	Test Conditions
		Min	Typ	Max		
Output low voltage (all other outputs)	V_{OL3}		0.45		V	$I_{\text{OL}} = 2.0\text{ mA}$
Output high voltage (bus)	V_{OH}	2.4			V	$I_{\text{OH}} = -400\ \mu\text{A}$
Output high voltage (RD, WR, PSEN, ALE)	V_{OH1}	2.4			V	$I_{\text{OH}} = -400\ \mu\text{A}$
Output high voltage (all other outputs)	V_{OH2}	2.4			V	$I_{\text{OH}} = -40\ \mu\text{A}$
Input leakage current (T1, INT)	I_{IL}			± 10	μA	$V_{\text{SS}} \leq V_{\text{IN}} \leq V_{\text{CC}}$
Input leakage current (P10-P17, P20-P27, EA, SS)	I_{IL1}			-500	μA	$V_{\text{CC}} \geq V_{\text{IN}} \geq V_{\text{SS}} + 0.45\text{ V}$
Output leakage current (bus, TO, high impedance state)	I_{OL}			± 10	μA	$V_{\text{CC}} \geq V_{\text{IN}} \geq V_{\text{SS}} + 0.45\text{ V}$
Power down supply current	I_{DD}		4	8	mA	$T_A = 25^\circ\text{C}$
Total supply current	$I_{\text{DD}+}$ I_{CC}		50	80	mA	$T_A = 25^\circ\text{C}$
RAM standby voltage	V_{DD}	2.2		5.5	V	Standby mode. Reset $\leq 0.6\text{ V}$

AC Characteristics $T_A = 0^\circ\text{C}$ to $+70^\circ\text{C}$, $V_{\text{CC}} = V_{\text{DD}} = +5\text{ V} \pm 10\%$, $V_{\text{SS}} = 0\text{ V}$

Parameter	Symbol	Limits			Unit	Test Conditions
		Min	Typ	Max		
ALE pulse width	t_{LL}	410			ns	(Note 1)
Address setup to ALE	t_{AL}	220			ns	(Note 1)
Address hold from ALE	t_{LA}	120			ns	(Note 1)
Control pulse width (RD, WR)	t_{CC1}	1050			ns	(Note 1)
Control pulse width (PSEN)	t_{CC2}	800			ns	(Note 1)
Data setup WR	t_{DW}	880			ns	(Note 1)
Data hold after WR	t_{WD}	110			ns	(Note 2)
Data hold (RD, PSEN)	t_{DR}	0		220	ns	(Note 1)
RD to data in	t_{RD1}			800	ns	(Note 1)
PSEN to data in	t_{RD2}			550	ns	(Note 1)

AC Characteristics (cont)

$T_A = 0^\circ\text{C}$ to $+70^\circ\text{C}$, $V_{CC} = V_{DD} = +5\text{V} \pm 10\%$, $V_{SS} = 0\text{V}$

Parameter	Symbol	Limits			Unit	Test Conditions
		Min	Typ	Max		
Address setup to WR	t_{AW}	680			ns	(Note 1)
Address setup to data (RD)	t_{AD1}			1570	ns	(Note 1)
Address setup to data (PSEN)	t_{AD2}			1090	ns	(Note 1)
Address float to RD, WR	t_{AFC1}	290			ns	(Note 1)
Address float to PSEN	t_{AFC2}	40			ns	(Note 1)
ALE to control (RD, WR)	t_{LAFC1}	420			ns	(Note 1)
ALE to control (PSEN)	t_{LAFC2}	170			ns	(Note 1)
Control to ALE (RD, WR, PROG)	t_{CA1}	120			ns	(Note 1)
Control to ALE (PSEN)	t_{CA2}	620			ns	(Note 1)
Port control setup to PROG	t_{CP}	210			ns	(Note 1)
Port control hold to PROG	t_{PC}	460			ns	(Note 1)
PROG to P2 input valid	t_{PR}		1300		ns	(Note 1)
Input data hold from PROG	t_{PF}		250		ns	(Note 1)
Output data setup	t_{DP}	850			ns	(Note 1)
Output data hold	t_{DD}	200			ns	(Note 1)
PROG pulse width	t_{PP}	1500			ns	(Note 1)
Port 2 I/O data setup to ALE	t_{PL}	460			ns	(Note 1)
Port 2 I/O data hold to ALE	t_{LP}	150			ns	(Note 1)
Port output from ALE	t_{PV}		850		ns	(Note 1)
Cycle time	t_{CY}	2.5	15		μs	(Note 1)
T0 rep rate	t_{OPRR}	500			ns	(Note 1)

Note:

- (1) Control outputs: $C_L = 80\text{ pF}$, bus outputs: $C_L = 150\text{ pF}$
- (2) Bus high impedance, load = 20 pF

Timing Waveforms

Instruction Fetch from External Memory

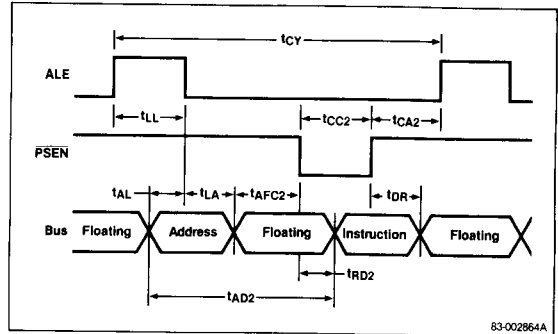

83-002864A

Read from External Data Memory

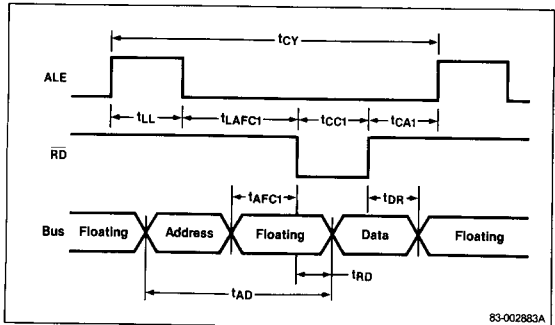

83-002883A

Write to External Memory

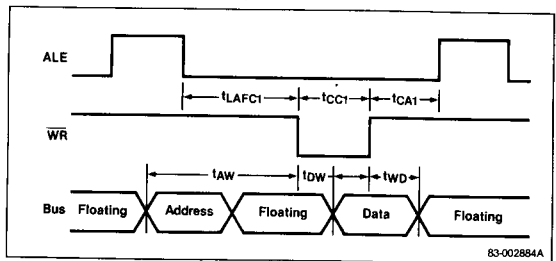

83-002884A

4

Timing Waveforms (cont)

Port 2 Timing

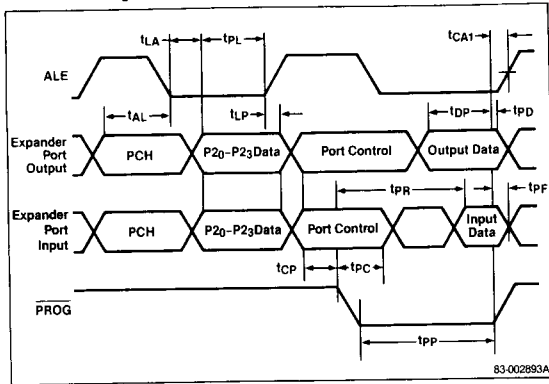

Bus Timing Requirements

Symbol	Timing Formula	Min/Max	Unit
t_{LL}	$(7/30) t_{CY} - 170$	Min	ns
t_{AL}	$(2/15) t_{CY} - 110$	Min	ns
t_{LA}	$(1/15) t_{CY} - 40$	Min	ns
t_{CC1}	$(1/2) t_{CY} - 200$	Min	ns
t_{CC2}	$(2/5) t_{CY} - 200$	Min	ns
t_{DW}	$(13/30) t_{CY} - 200$	Min	ns
t_{WD}	$(1/15) t_{CY} - 50$	Min	ns
t_{DR}	$(1/10) t_{CY} - 30$	Max	ns
t_{RD1}	$(2/5) t_{CY} - 200$	Max	ns
t_{RD2}	$(3/10) t_{CY} - 200$	Max	ns
t_{AW}	$(1/3) t_{CY} - 150$	Min	ns
t_{AD1}	$(11/15) t_{CY} - 250$	Max	ns
t_{AD2}	$(8/15) t_{CY} - 250$	Max	ns
t_{AFC1}	$(2/15) t_{CY} - 40$	Min	ns
t_{AFC2}	$(1/30) t_{CY} - 40$	Min	ns
t_{LAF1}	$(1/5) t_{CY} - 75$	Min	ns
t_{LAF2}	$(1/10) t_{CY} - 75$	Min	ns
t_{CA1}	$(1/15) t_{CY} - 40$	Min	ns
t_{CA2}	$(4/15) t_{CY} - 40$	Min	ns
t_{CP}	$(1/10) t_{CY} - 40$	Min	ns
t_{PC}	$(4/15) t_{CY} - 200$	Min	ns
t_{PR}	$(17/30) t_{CY} - 120$	Max	ns
t_{PF}	$(1/10) t_{CY}$	Max	ns
t_{DP}	$(2/5) t_{CY} - 150$	Min	ns
t_{PD}	$(1/10) t_{CY} - 50$	Min	ns
t_{PP}	$(7/10) t_{CY} - 250$	Min	ns
t_{PL}	$(4/15) t_{CY} - 200$	Min	ns
t_{LP}	$(1/10) t_{CY} - 100$	Min	ns
t_{PV}	$(3/10) t_{CY} - 100$	Max	ns
t_{OPRR}	$(3/15) t_{CY}$	Min	ns
t_{CY}	6 MHz		μs

Instruction Set

Mnemonic	Function	Description	Operation Code										Flags				
			D7	D6	D5	D4	D3	D2	D1	D0	Cycles	Bytes	C	AC	F0	F1	
Accumulator																	
ADD A, # data	(A) ← (A) + data	Add immediate the specified data to the accumulator.	0	0	0	0	0	0	0	1	1	2	2	•			
	d7		d7	d6	d5	d4	d3	d2	d1	d0							
ADD A, Rr	(A) ← (A) + (Rr) r = 0-7	Add contents of designated register to the accumulator.	0	1	1	0	1	r	r	r	r	1	1	•			
ADD A, @ Rr	(A) ← (A) + ((Rr)) r = 0-1	Add indirect the contents of the data memory location to the accumulator.	0	1	1	0	0	0	0	0	r	1	1	•			
ADDC A, # data	(A) ← (A) + (C) + data	Add immediate with carry the specified data to the accumulator.	0	0	0	1	0	0	1	1	2	2	•				
	d7		d7	d6	d5	d4	d3	d2	d1	d0							
ADDC A, Rr	(A) ← (A) + (C) + (Rr) for r = 0-7	Add with carry the contents of the designated register to the accumulator.	0	1	1	1	1	r	r	r	r	1	1	•			
ADDC A, @ Rr	(A) ← (A) + (C) + ((Rr)) for r = 0-1	Add indirect with carry the contents of data memory location to the accumulator.	0	1	1	1	0	0	0	0	r	1	1	•			
ANL A, # data	(A) ← (A) AND data	Logical AND specified immediate data with accumulator.	0	1	0	1	0	0	1	1	2	2					
	d7		d7	d6	d5	d4	d3	d2	d1	d0							
ANL A, Rr	(A) ← (A) AND (Rr) r = 0-7	Logical AND contents of designated register with accumulator.	0	1	0	1	1	r	r	r	r	1	1				
ANL A, @ Rr	(A) ← (A) AND ((Rr)) r = 0-1	Logical AND indirect the contents of data memory with accumulator.	0	1	0	1	0	0	0	0	r	1	1				
CPL A	(A) ← NOT (A)	Complement the contents of the accumulator.	0	0	1	1	0	1	1	1	1	1	1				
CLR A	(A) ← 0	Clear the contents of the accumulator.	0	0	1	0	0	1	1	1	1	1	1				
DA A	(A) ← (A) - 1	Decimal adjust the contents of the accumulator.	0	1	0	1	0	1	1	1	1	1	1	•			
DEC A	(A) ← (A) - 1	Decrement by 1 the accumulator's contents.	0	0	0	0	0	1	1	1	1	1	1				
INC A	(A) ← (A) + 1	Increment by 1 the accumulator's contents.	0	0	0	1	0	1	1	1	1	1	1				
ORL A, # data	(A) ← (A) OR data	Logical OR specified immediate data with accumulator.	0	1	0	0	0	0	1	1	2	2					
	d7		d7	d6	d5	d4	d3	d2	d1	d0							
ORL A, Rr	(A) ← (A) OR (Rr) for r = 0-7	Logical OR contents of designated register with accumulator.	0	1	0	0	1	r	r	r	r	1	1				
ORL A, @ Rr	(A) ← (A) OR ((Rr)) for r = 0-1	Logical OR indirect the contents of data memory location with accumulator.	0	1	0	0	0	0	0	0	r	1	1				
Rl	(AN + 1) ← (AN); N = 0-6 (A0) ← (A7)	Rotate accumulator left by 1 bit without carry.	1	1	1	0	0	1	1	1	1	1	1				
Rr	(AN + 1) ← (AN); N = 0-6 (A0) ← (C) (C) ← (A7)	Rotate accumulator left by 1 bit through carry.	1	1	1	1	0	1	1	1	1	1	1	•			
Rr	(AN) ← (AN + 1); N = 0-6 (A7) ← (A0)	Rotate accumulator right by 1 bit without carry.	0	1	1	1	0	1	1	1	1	1	1				

Instruction Set (cont)

Mnemonic	Function	Description	Operation Code								Flags											
			D ₇	D ₆	D ₅	D ₄	D ₃	D ₂	D ₁	D ₀	Cycles	Bytes	C	AC	F0	F1						
Accumulator (cont)																						
RRC A	(AN) ← (AN + 1); N = 0-6 (A ₇) ← (C) (C) ← (A ₀)	Rotate accumulator right by 1 bit through carry.	0	1	1	0	0	1	1	1	1	1	1	1	1	•						
SWAP A	(A ₄ -A ₇) ← (A ₀ -A ₃)	Swap the two 4-bit nibbles in the accumulator.	0	1	0	0	0	1	1	1	1	1	1	1	1							
XRL A, # data	(A) ← (A) XOR data	Logical XOR specified immediate data with accumulator.	1	1	0	1	0	0	1	1	2	2	d ₇	d ₆	d ₅	d ₄	d ₃	d ₂	d ₁	d ₀		
XRL A, Rr	(A) ← (A) XOR (Rr) for r = 0-7	Logical XOR contents of designated register with accumulator.	1	1	0	1	1	1	r	r	1	1	1	r	r	r	r	r	r	r	1	
XRL A, @ Rr	(A) ← (A) XOR ((Rr)) for r = 0-1	Logical XOR indirect the contents of data memory location with accumulator.	1	1	0	1	0	0	0	0	1	1	1	0	0	0	0	0	0	0	r	1
Branch																						
DJNZ Rr, addr	(Rr) ← (Rr) - 1; r = 0-7 if (Rr) = 0; (PC ₀ -PC ₇) ← addr	Decrement the specified register and test contents.	1	1	1	0	1	r	r	r	2	2	a ₇	a ₆	a ₅	a ₄	a ₃	a ₂	a ₁	a ₀		
JCb addr	(PC ₀ -PC ₇) ← addr; if B ₀ = 1 (PC) ← (PC) + 2; if B ₀ = 0	Jump to specified address if accumulator bit is set.	b ₂	b ₁	b ₀	1	0	0	1	0	2	2	a ₇	a ₆	a ₅	a ₄	a ₃	a ₂	a ₁	a ₀		
JC addr	(PC ₀ -PC ₇) ← addr; if C = 1 (PC) ← (PC) + 2; if C = 0	Jump to specified address if carry flag is set.	1	1	1	1	0	1	1	0	2	2	a ₇	a ₆	a ₅	a ₄	a ₃	a ₂	a ₁	a ₀		
JFO addr	(PC ₀ -PC ₇) ← addr; if F0 = 1 (PC) ← (PC) + 2; if F0 = 0	Jump to specified address if flag F0 is set.	1	0	1	1	0	1	1	0	2	2	a ₇	a ₆	a ₅	a ₄	a ₃	a ₂	a ₁	a ₀		
JF1 addr	(PC ₀ -PC ₇) ← addr; if F1 = 1 (PC) ← (PC) + 2; if F1 = 0	Jump to specified address if flag F1 is set.	0	1	1	1	0	1	1	0	2	2	a ₇	a ₆	a ₅	a ₄	a ₃	a ₂	a ₁	a ₀		
JMP addr	(PC ₀ -PC ₁₀) ← (addr); addr ₁₀ (PC ₀ -PC ₇) ← (addr); addr ₇ (PC ₁₁) ← DBF	Direct jump to specified address within the 2K address block.	a ₁₀	a ₉	a ₈	0	0	1	0	0	2	2	a ₇	a ₆	a ₅	a ₄	a ₃	a ₂	a ₁	a ₀		
JMPP @ A	(PC ₀ -PC ₇) ← ((A))	Jump indirect to specified address with address page.	1	0	1	1	0	0	1	1	2	1										
JNC addr	(PC ₀ -PC ₇) ← addr; if C = 0 (PC) ← (PC) + 2; if C = 1	Jump to specified address if carry flag is low.	1	1	1	0	0	1	1	0	2	2	a ₇	a ₆	a ₅	a ₄	a ₃	a ₂	a ₁	a ₀		
JN1 addr	(PC ₀ -PC ₇) ← addr; if I = 0 (PC) ← (PC) + 2; if I = 1	Jump to specified address if interrupt is low.	1	0	0	0	0	1	1	0	2	2	a ₇	a ₆	a ₅	a ₄	a ₃	a ₂	a ₁	a ₀		
JNT0 addr	(PC ₀ -PC ₇) ← addr; if T0 = 0 (PC) ← (PC) + 2; if T0 = 1	Jump to specified address if test 0 is low.	0	0	1	0	0	1	1	0	2	2	a ₇	a ₆	a ₅	a ₄	a ₃	a ₂	a ₁	a ₀		
JNT1 addr	(PC ₀ -PC ₇) ← addr; if T1 = 0 (PC) ← (PC) + 2; if T1 = 1	Jump to specified address if test 1 is low.	0	1	0	0	0	1	1	0	2	2	a ₇	a ₆	a ₅	a ₄	a ₃	a ₂	a ₁	a ₀		
JNZ addr	(PC ₀ -PC ₇) ← addr; if A = 0 (PC) ← (PC) + 2; if A = 1	Jump to specified address if accumulator is non-zero.	1	0	0	1	0	1	1	0	2	2	a ₇	a ₆	a ₅	a ₄	a ₃	a ₂	a ₁	a ₀		
JTF addr	(PC ₀ -PC ₇) ← addr; if TF = 1 (PC) ← (PC) + 2; if TF = 0	Jump to specified address if timer flag is set to 1.	0	0	0	1	0	1	1	0	2	2	a ₇	a ₆	a ₅	a ₄	a ₃	a ₂	a ₁	a ₀		

Instruction Set (cont)

Mnemonic	Function	Description	Operation Code										Flags					
			D7	D6	D5	D4	D3	D2	D1	D0	Cycles	Bytes	C	AC	F0	F1		
Branch (cont)																		
JTO addr	(PC ₀ -PC ₇) ← addr if T0 = 1 (PC) ← (PC) + 2 if T0 = 0	Jump to specified address if test 0 is a 1.	0	0	1	1	0	1	1	0	1	1	0	2	2			
JT1 addr	(PC ₀ -PC ₇) ← addr if T1 = 1 (PC) ← (PC) + 2 if T1 = 0	Jump to specified address if test 1 is a 1.	0	1	0	1	0	1	0	1	1	1	0	2	2			
JZ addr	(PC ₀ -PC ₇) ← addr if A = 0 (PC) ← (PC) + 2 if A = 1	Jump to specified address if accumulator is 0.	1	1	0	0	0	1	1	1	0	1	0	2	2			
Control																		
EN I		Enable the external interrupt input.	0	0	0	0	0	1	0	1	0	1	1	1	1			
DIS I		Disable the external interrupt input.	0	0	0	1	0	1	0	1	0	1	1	1	1			
EN TO CLK		Enable the clock output pin T0.	0	1	1	1	0	1	0	1	0	1	1	1	1			
SEL MB0	(0BF) ← 0	Select bank 0 (locations 0-2047) of program memory.	1	1	1	0	0	1	0	1	0	1	1	1	1			
SEL MB1	(0BF) ← 1	Select bank 1 (locations 2048-4095) of program memory.	1	1	1	1	0	1	0	1	0	1	1	1	1			
SEL RB0	(8S) ← 0	Select bank 0 (locations 0-7) of data memory.	1	1	0	0	0	1	0	1	0	1	1	1	1			
SEL RB1	(8S) ← 1	Select bank 1 (locations 24-31) of data memory.	1	1	0	1	0	1	0	1	0	1	1	1	1			
Data Moves																		
MOV A, # data	(A) ← data	Move immediate the specified data into the accumulator.	0	0	1	0	0	0	1	1	2	2		2				
MOV A, Rr	(A) ← (Rr); r = 0-7	Move the contents of the designated registers into the accumulator.	1	1	1	1	1	1	r	r	r	r	1	1	1			
MOV A, @ Rr	(A) ← ((Rr)); r = 0-1	Move indirect the contents of data memory location into the accumulator.	1	1	1	1	0	0	0	0	0	r	1	1				
MOV A, PSW	(A) ← (PSW)	Move contents of the program status word into the accumulator.	1	1	0	0	0	1	1	1	1	1	1	1	1			
MOV Rr, # data	(Rr) ← data; r = 0-7	Move immediate the specified data into the designated register.	1	0	1	1	1	1	r	r	r	r	2	2				
MOV Rr, A	(Rr) ← (A); r = 0-7	Move accumulator contents into the designated register.	1	0	1	0	1	0	1	0	1	1	1	1	1			
MOV @ Rr, A	((Rr)) ← (A); r = 0-1	Move indirect accumulator contents into data memory location.	1	0	1	0	0	0	0	0	0	r	1	1				
MOV @ Rr, # data	((Rr)) ← data; r = 0-1	Move immediate the specified data into data memory.	1	0	1	1	1	1	0	0	0	1	2	2				
MOV @ PSW, A	(PSW) ← (A)	Move contents of accumulator into the program status word.	1	1	0	1	0	1	0	1	1	1	1	1	1			
MOV @ A, @ A	(PC ₀ -PC ₇) ← (A) (A) ← ((PC))	Move data in the current page into the accumulator.	1	0	1	0	0	0	1	1	2	1						
MOV @3 A, @ A	(PC ₀ -PC ₇) ← (A) (PC ₈ -PC ₁₀) ← 011 (A) ← ((PC))	Move program data in page 3 into the accumulator.	1	1	1	0	0	0	1	1	2	1						

Instruction Set (cont)

Mnemonic	Function	Description	Operation Code								Flags						
			D ₇	D ₆	D ₅	D ₄	D ₃	D ₂	D ₁	D ₀	Cycles	Bytes	C	AC	F0	F1	
Data Moves (cont)																	
MOVX A, @ R	(A) ← ((Rr)); r = 0-1	Move indirect the contents of external data memory into the accumulator.	1	0	0	0	0	0	0	0	0	r	2	1			
MOVX @ R, A	((Rr)) ← (A); r = 0-1	Move indirect the contents of the accumulator into external data memory.	1	0	0	1	0	0	0	0	0	r	2	1			
XCH A, Rr	(A) ↔ (Rr); r = 0-7	Exchange the accumulator and designated register's contents.	0	0	1	0	1	r	r	r	r	r	1	1			
XCH A, @ Rr	(A) ↔ ((Rr)); r = 0-1	Exchange indirect contents of accumulator and location in data memory.	0	0	1	0	0	0	0	0	0	r	1	1			
XCHD A, @ Rr	(A ₀ -A ₃) ↔ ((Rr)) ₀ -((Rr)) ₃ ; r = 0-1	Exchange indirect 4-bit contents of accumulator and data memory.	0	0	1	1	0	0	0	0	0	r	1	1			
Flags																	
CPL C	(C) ← NOT (C)	Complement contents of carry bit.	1	0	1	0	0	1	1	1	1	1	1	1	•		
CPL F0	(F0) ← NOT (F0)	Complement contents of flag F0.	1	0	0	1	0	1	0	1	1	1	1	1	•		
CPL F1	(F1) ← NOT (F1)	Complement contents of flag F1.	1	0	1	1	0	1	0	1	1	1	1	1	•		
CLR C	(C) ← 0	Clear contents of carry bit to 0.	1	0	0	1	0	1	1	1	1	1	1	1	•		
CLR F0	(F0) ← 0	Clear contents of flag 0 to 0.	1	0	0	0	0	1	0	1	1	1	1	1	•		
CLR F1	(F1) ← 0	Clear contents of flag 1 to 0.	1	0	1	0	0	1	0	1	1	1	1	1	•		
Input / Output																	
ANL BUS, # data	(bus) ← (bus) AND data	Logical AND immediate specified data with contents of bus.	1	0	0	1	1	0	0	0	0	0	2	2			
			d ₇	d ₆	d ₅	d ₄	d ₃	d ₂	d ₁	d ₀							
ANL Pp, # data	(Pp) ← (Pp) AND data p = 1-2	Logical AND immediate specified data with designated port (1 or 2).	1	0	0	1	1	0	p	p	p	2	2				
			d ₇	d ₆	d ₅	d ₄	d ₃	d ₂	d ₁	d ₀							
ANLD Pp, A	(Pp) ← (Pp) AND (A ₀ -A ₃); p = 4-7	Logical AND contents of accumulator with designated port (4-7).	1	0	0	1	1	1	p	p	p	2	1				
IN A, Pp	(A) ← (Pp); p = 1-2	Input data from designated port (1-2) into accumulator.	0	0	0	0	1	0	p	p	p	2	1				
INS A, BUS	(A) ← (bus)	Input strobed bus data into accumulator.	0	0	0	0	1	0	0	0	0	2	1				
MOV D A, Pp	(A ₀ -A ₃) ← (Pp); p = 4-7 (A ₄ -A ₇) ← 0	Move contents of designated port (4-7) into accumulator.	0	0	0	0	1	1	p	p	p	2	1				
MOV D Pp, A	(Pp) ← (A ₀ -A ₃); p = 4-7	Move contents of accumulator to designated port (4-7).	0	0	1	1	1	1	p	p	p	2	1				
ORL BUS, # data	(bus) ← (bus) OR data	Logical OR immediate specified data with contents of bus.	1	0	0	0	1	0	0	0	0	2	2				
			d ₇	d ₆	d ₅	d ₄	d ₃	d ₂	d ₁	d ₀							
ORL D Pp, A	(Pp) ← (Pp) OR (A ₀ -A ₃); p = 4-7	Logical OR contents of accumulator with designated port (4-7).	1	0	0	0	1	1	p	p	p	2	1				
ORL Pp, # data	(Pp) ← (Pp) OR data p = 1-2	Logical OR immediate specified data with designated port (1-2).	1	0	0	0	1	0	p	p	p	2	2				
			d ₇	d ₆	d ₅	d ₄	d ₃	d ₂	d ₁	d ₀							
OUTL BUS, A	(bus) ← (A)	Output contents of accumulator onto bus.	0	0	0	0	0	0	0	1	0	2	1				
OUTL Pp, A	(Pp) ← (A); p = 1-2	Output contents of accumulator to designated port (1-2).	0	0	1	1	1	0	p	p	p	2	1				

Instruction Set (cont)

Mnemonic	Function	Description	Operation Code																Flags																			
			D7	D6	D5	D4	D3	D2	D1	D0	Cycles	Bytes	C	AC	F0	F1																						
Subroutine																																						
Registers																																						
DEC Rr (Rr)	(Rr) ← (Rr) - 1; r = 0-7	Decrement by 1 contents of designated register.	1	1	0	0	1	r	r	r	1	1																										
INC Rr	(Rr) ← (Rr) + 1; r = 0-7	Increment by 1 contents of designated register.	0	0	0	1	1	r	r	r	1	1																										
INC @ Rr	((Rr)) ← ((Rr)) + 1; r = 0-1	Increment indirect by 1 the contents of data memory location.	0	0	0	1	0	0	0	0	r	1																										
CALL addr	((SP)) ← (PC), (PSW4-PSW7), (SP) ← (SP) + 1 (PC8-PC0) ← (addr8-addr0) (PC0-PC7) ← (addr0-addr7) (PC11) ← DBF	Call designated subroutine.	a10	a9	a8	1	0	1	0	1	0	0	2	2																								
			a7	a6	a5	a4	a3	a2	a1	a0																												
RET	(SP) ← (SP) = 1 (PC) ← ((SP))	Return from subroutine without restoring program status word.	1	0	0	0	0	0	1	1	2	1																										
RETR	(SP) ← (SP) = 1 (PC) ← ((SP)) (PSW4-PSW7) ← ((SP))	Return from subroutine restoring program status word.	1	0	0	1	0	0	1	1	2	1																										
Timer / Counter																																						
EN TCNTI		Enable internal interrupt flag for timer / counter output.	0	0	1	0	0	1	0	1	1	1																										
DIS TCNTI		Disable internal interrupt flag for timer / counter output.	0	0	1	1	0	1	0	1	1	1																										
MOV A, T	(A) ← (T)	Move contents of timer / counter into accumulator.	0	1	0	0	0	0	1	0	1	1																										
MOV T, A	(T) ← (A)	Move contents of accumulator into timer / counter.	0	1	1	0	0	0	1	0	1	1																										
STOP TCNT		Stop count for event counter.	0	1	1	0	0	1	0	1	1	1																										
START CNT		Start count for event counter.	0	1	0	0	0	1	0	1	1	1																										
START T		Start count for timer.	0	1	0	1	0	1	0	1	1	1																										
Miscellaneous																																						
NOP		No operation performed.	0	0	0	0	0	0	0	0	0	1																										

Note:

- (1) Operation code designations r and p form the binary representation of the registers and ports involved.
- (2) The dot under the appropriate flag bit indicates that its content is subject to change by the instruction it appears in.
- (3) References to the address and data are specified in bytes 2 and/or 1 of the instruction.
- (4) Numerical subscripts appearing in the function column reference the specific bits affected.
- (5) When the bus is written to, with an OUTL instruction, the bus remains an output port until either device is reset or a MOVX instruction is executed.

www.DataSheet4U.com

Instruction Set Symbol Definitions

Symbol	Description
A	Accumulator
AC	Auxiliary carry flag
addr	Program memory address (12 bits)
B _b	Bit designator (b = 0-7)
BS	Bank switch
BUS	Bus port
C	Carry flag
CLK	Clock signal
CNT	Event counter
D	Nibble designator (4 bits)
data	Number of expression (8 bits)
DBF	Memory bank flip-flop
F0, F1	Flags 0, 1
I	Interrupt
P	"In-page" operation designator
Pp	Port designator (p = 1, 2 or 4-7)
PSW	Program status word
Rr	Register designator (r = 0, 1 or 0-7)
SP	Stack pointer
T	Timer
TF	Timer flag
T0, T1	Testable flags 0, 1
X	External RAM
#	Prefix for immediate data
@	Prefix for indirect address
\$	Program counter's current value
(x)	Contents of external RAM location
((x))	Contents of memory location addressed by the contents of external RAM location
←	Replaced by
AND	Logical product (logical AND)
OR	Logical sum (logical OR)
XOR	Exclusive-OR

Operating Characteristics

Bus Output High Voltage vs. Source Current

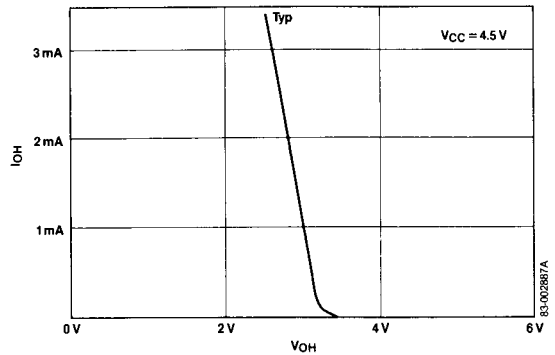

Port P1 & P2 Output High Voltage vs. Source Current

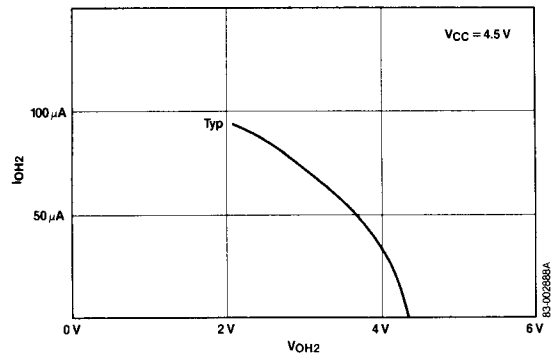

Bus Output Low Voltage vs. Sink Current

