

---

# HKT100\*\*\*U/HKT100Y01U

μ-Chip (RFID)

REJ03P0006-0101

Rev.1.01

Feb 23, 2007

---

## Overview

- HKT100\*\*\*U/HKT100Y01U is RFID (Radio Frequency Identification) for 2.45 GHz.
- It has a unique ID inside, then it is applicable for management of individual object.

Note: "\*\*\*" or "Y01" is a ROM code.

## Feature

- Thin and small package: URP (PTSP0002ZA-A)
- Including unique μ-Chip ID which is not alterable
- Communication without contact

Note: "μ-Chip" and the μ-Chip Logo are either registered Trademarks or Trademarks of Hitachi,Ltd. in Japan and in other countries.

### Order Part No.

Order Part No.	Unit of Packaging	Packing Form	Unit of Order	Note
HKT100***U	3,000	Taping	75,000	
HKT100Y01U	3,000	Taping	3,000	

### Outline and Mark

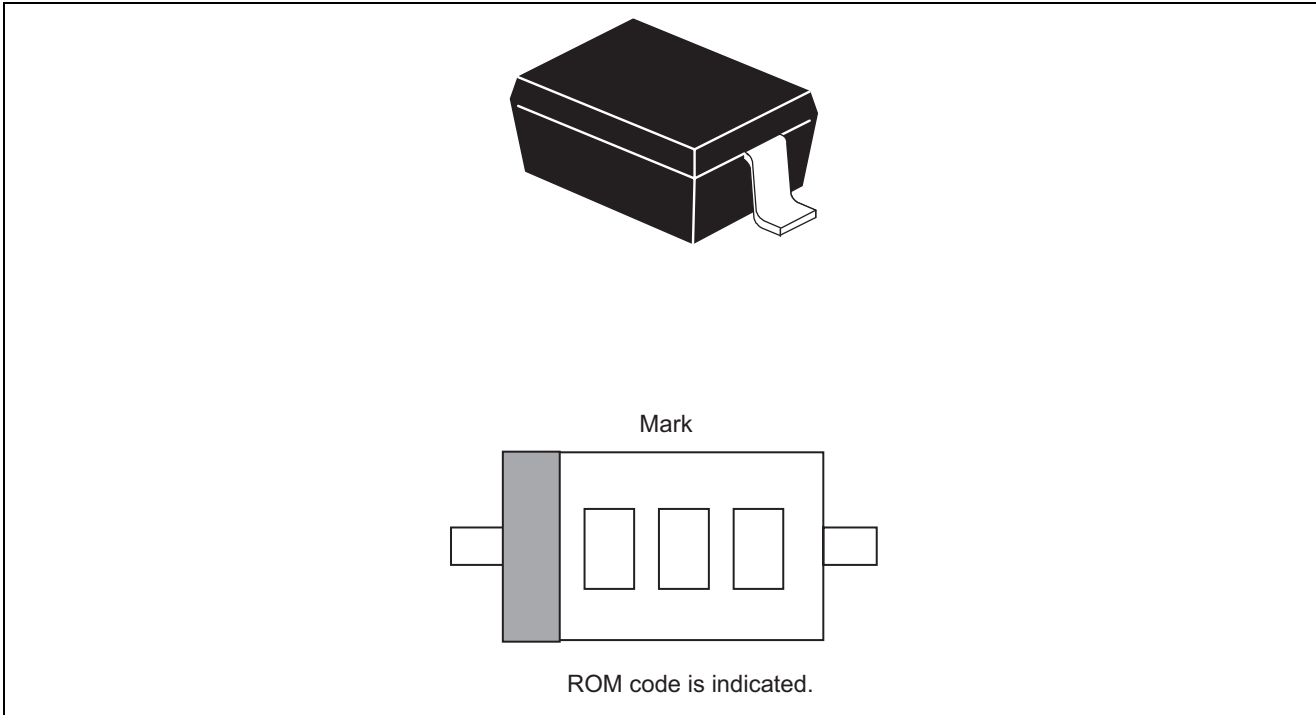

## Absolute Maximum Ratings

Item	Symbol	Specification			Unit	Condition	Remark
		Min	Typ	Max			
Storage temperature	Tstg	-30	—	75	°C		
Ambient operation temperature	Ta	0	25	40	°C		No condensation
Received power	Pr	—	—	13.8	dBm		

## Electrical Characteristics

Measurement conditions:

Unless otherwise specified, Ta = 25°C, fc = 2.416 ± 0.010 GHz, reader power = 150 mW

Single-patch antenna, linearity polarized waves, clock cycle = 10 μs, clock duty cycle = 85%

Period of reading operations: 8 clock cycles, number of read bits: 128 bits

Product is measured under the condition that it is pressed onto the antenna shown in figure 1.

Please refer the preceding sheet.

Item	Specification			Unit	Condition	Remark
	Min	Typ	Max			
Communication distance	6.5	—	13	cm	Note4	Note1
μ-Chip ID Check	—	Passed	—	—	EDC Check	Note2, Note3

- Notes: 1. The distance at which the read μ-Chip ID value matches the indicated value and the EDC check is passed.  
 2. Verification value calculated from the read μ-Chip ID value.  
 3. Detail data of μ-Chip ID is describe on the commodity specification.  
 4. Relation between the evaluation antenna and antenna positions;

The planes of the gilded pattern for the evaluation antenna and the antenna itself should be parallel, the center of the evaluation antenna should be on the line that passes through the center of the antenna plane, and the gilded pattern's longer side should be within the antenna's plane of polarization.

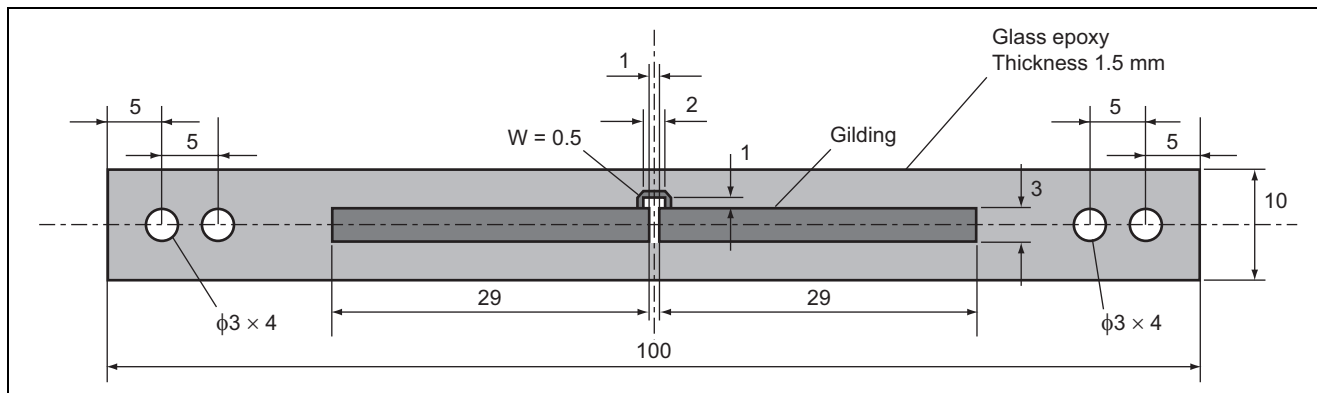

Figure 1 Evaluation Antenna

**Reader Specifications and Type No.: MR-STD2**

Item	Symbol	Specification	Unit	Remarks
Operation temperature	Ta	25	°C	
Carrier frequency	fc	2.416 ± 0.010	GHz	
Power	Pw	150	mW	
Clock cycle	Tclk	10	μs	
Clock duty ratio	duty	85	%	
Data read cycle	Tfm	8	Clock	
Data read bit count	Nb	128	Bits	

**Cable Specifications**

Item	Symbol	Specification	Unit	Remarks
Cable material	—	semi-rigid	—	
Total length of cable	L	20	cm	

**Antenna Specifications and Type No.: PA1-2450AS**

Item	Symbol	Specification	Unit	Remarks
Operation temperature	Ta	25	°C	
Polarization	—	Linear	—	
Number of patches	—	1	pcs	
Gain	—	7	dBi	

## Dimension of Inlet Outline

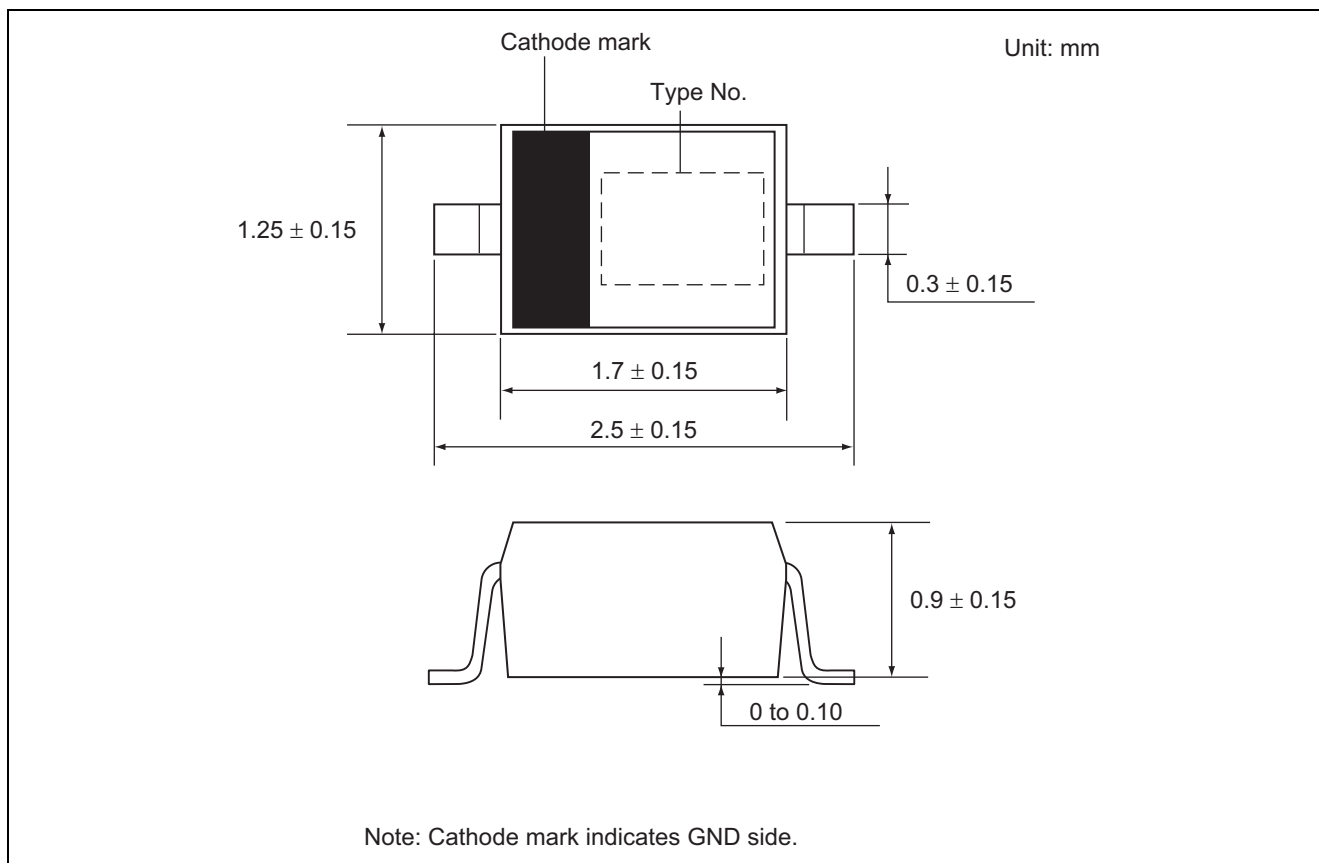

## Packing Specifications

### Taping Specification

#### 1. Direction of Device

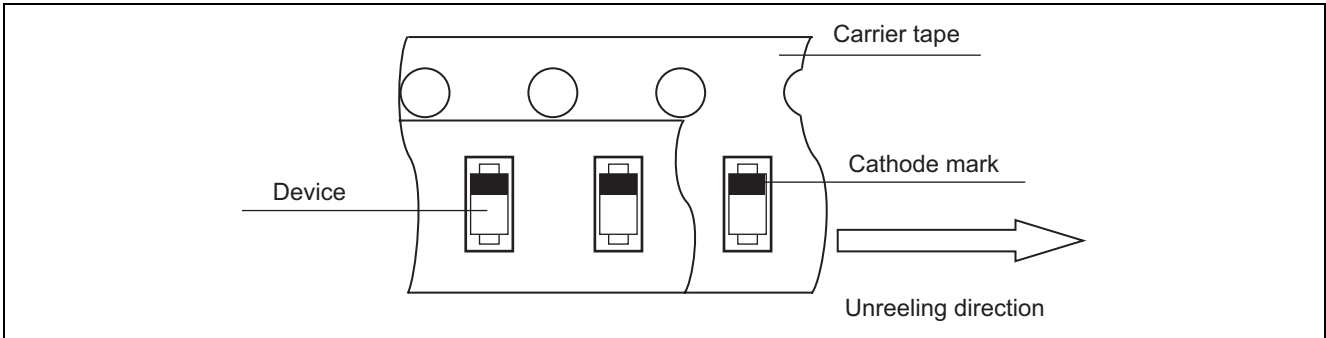

#### 2. Taping Dimensions

##### a. Carrier Tape and Cover Tape

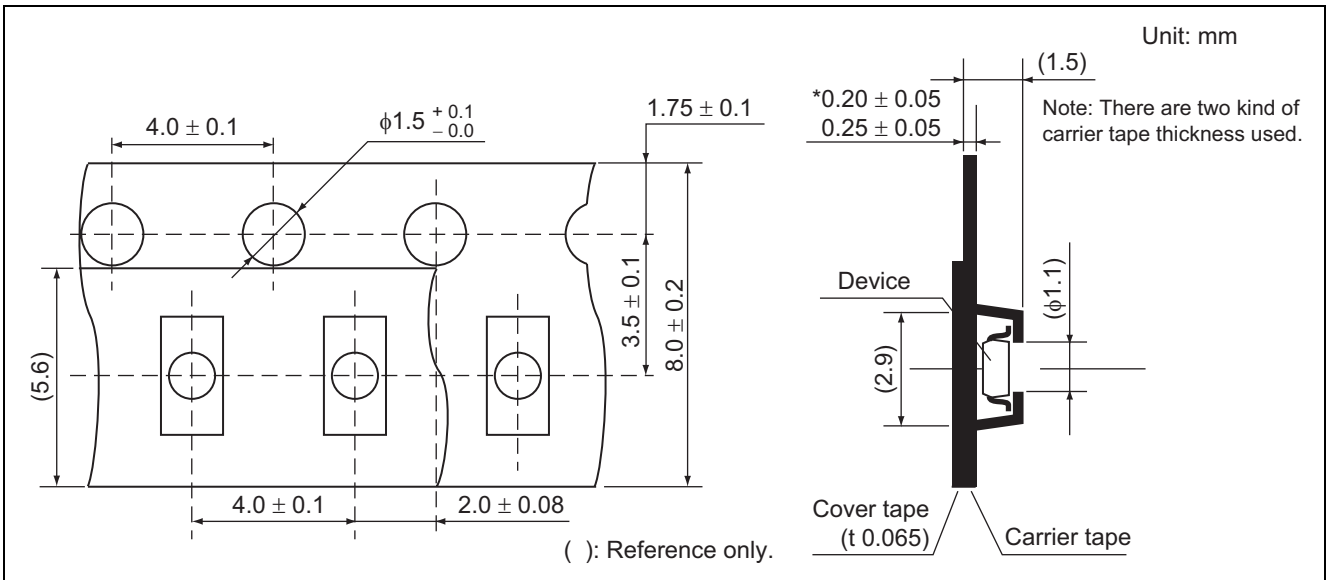

##### b. Leader and Trailer

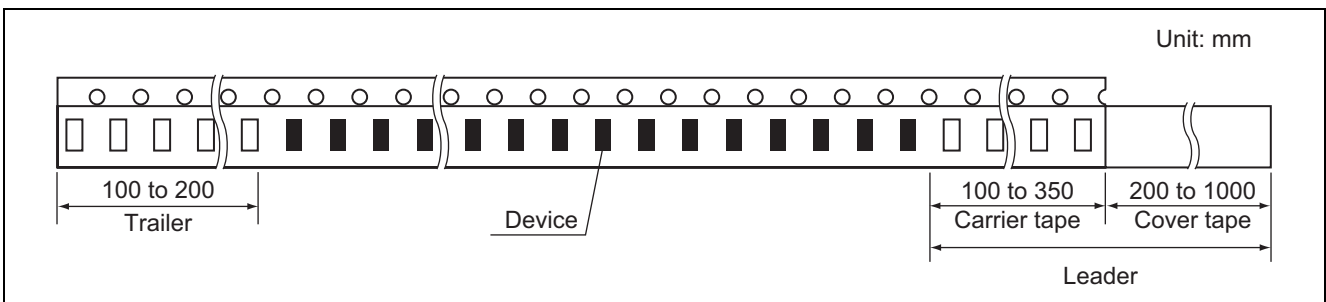

c. Reel Dimensions

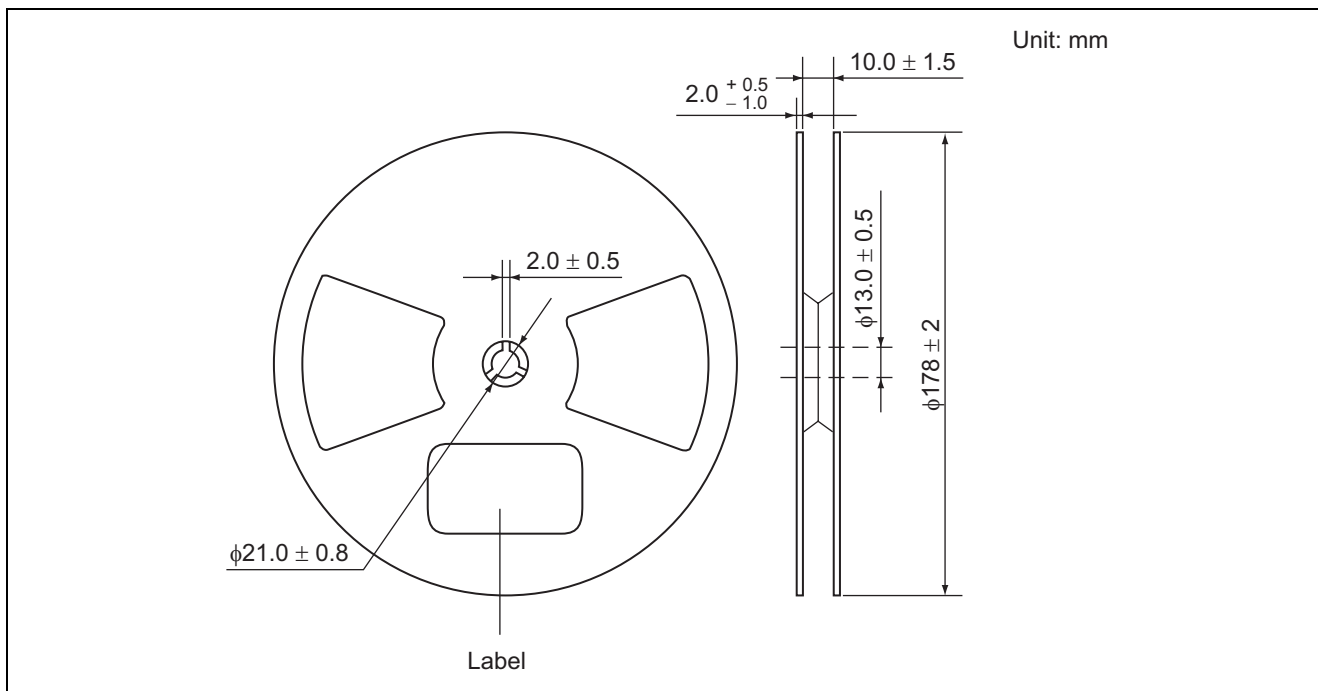

d. Example of Labeling

(For adapted lead free)

Notes:

1. Part No.
2. Management No. (Year, Month and Weekly code)
3. Quantity
4. Lot No.
5. Country of origin  
Japan → JAPAN  
Malaysia → MALAYSIA

## 3. Specifications

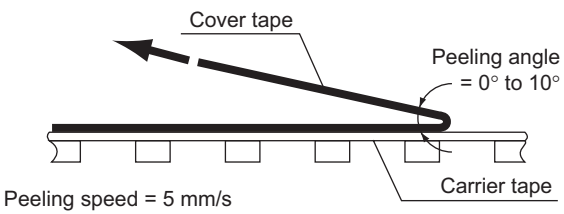
Item	Rated Value
Breaking force (F) of cover tape	Breaking force (F) = 0.10 to 0.69 N (10 to 70 g) <Measurement condition> 
Carrier tape (enclosed device) flexibility	Bending radius $\geq 30$ mm
Continuity	1. Missing devices $\leq 0.2\%$ / Reel 2. Continuous miss = 0 / Reel

## 4. Material

Item	Material
Carrier tape	Conductive plastics
Cover tape	Plastics
Reel	Polystyrene

## 5. Quantity of Devices

3,000 pieces/Reel



### Inner Packing Box

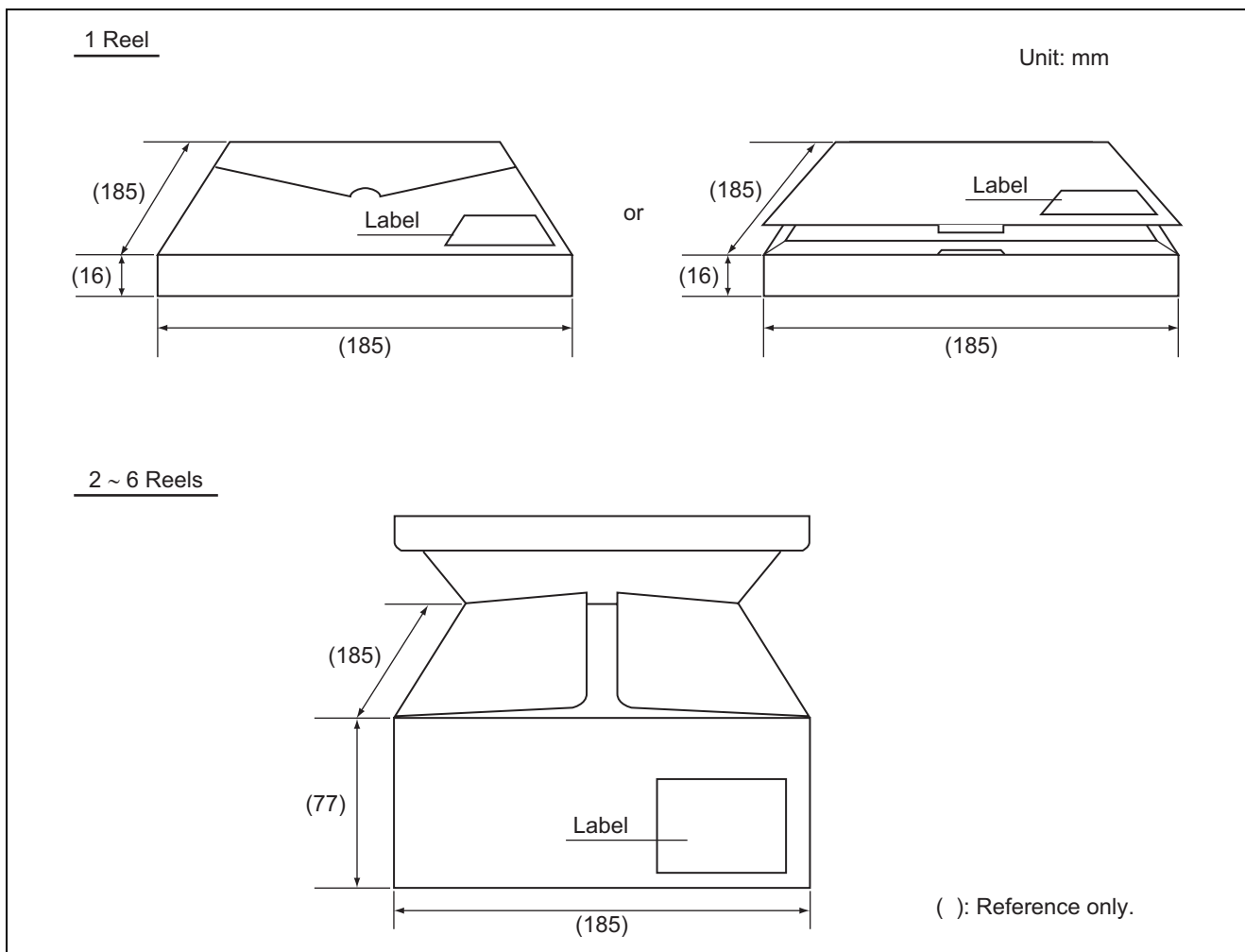

### Example of Labeling

(1) → PID 06100P10CV-001

(2) → D/N RKZ6.8TKJR1

(3) → QTY 8000

(4) → SPN RKZ6.8TKJR1 ZZZZ

(5) → WP MADE IN JAPAN T/C 6C2 FL90030E0

(6) → AS MADE IN JAPAN S.LOT FL90030E0

(7) Trace code

(8) Lot code

(9) Pb-Free indication (Only for Pb-free product)

(10) Date of Label issuance

(1) Pack-ID

(2) Device Name  
Note: Indicate "Q" the end of a device name only in the case of direct sale in Malaysia

(3) Quantity

(4) SAP Name

(5) Country of Wafer Process  
Japan → MADE IN JAPAN  
Malaysia → MADE IN MALAYSIA

(7) Trace code

(8) Lot code

(9) Pb-Free indication (Only for Pb-free product)

(10) Date of Label issuance

## Appearance

There should not be any scratch or/and dirt that affect characteristics.

## Quality Level

(Compliant with the JIS Z 9015)

Electrical characteristics: AQL = 4.0%

Appearance: AQL = 4.0%

## Precautions on Usage

1. Renesas Technology does not guarantee the product characteristics after it has been through assembly on the customer side.
2. Please refer to the mounting manual. (Document No.: REJ11P0006-0101)
3. As for this product, the electrostatic destruction prevention measures are not done because of the communication characteristic priority. Therefore, the electrostatic destruction voltage is about 50 V in machine model (EIAJ), and the static electricity level management in the process until a metallic antenna connecting is especially necessary.

## System Outline

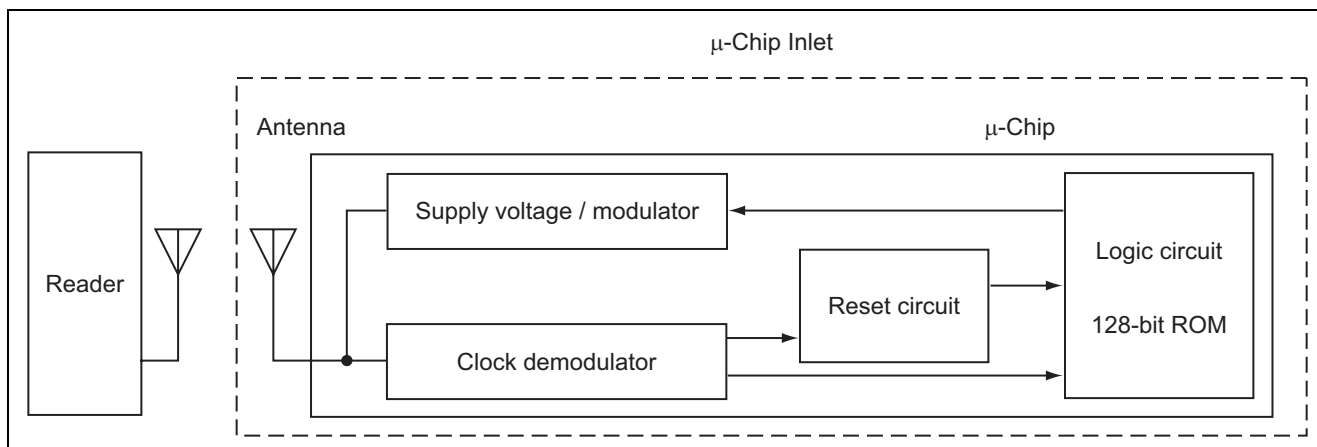

## Function Blocks

Block Name	Description of Functions
Supply voltage/modulator	Generates power-supply voltage from carrier signals, varies the output impedance of the modulator circuit to match the input impedance of the antenna, and handles communications. The IC incorporates a power limiter for the protection of internal devices.
Reset circuit	Determines whether or not a clock signal is being supplied and cancels the reset mode in synchronization with the first clock cycle.
Clock demodulator	Demodulates the clock signal from the envelope signal of the received signal.
Logic circuit	The IC includes an on-chip 128-bit ROM from which data signals are sent out in synchronization with the clock signal.

## Precautions for Storage, Transportation and Measuring

Note: These notes indicate a general item.

Please give priority to the notation in each C.S with Various kinds of notes originating in a product.

### 1. Other Precaution Involve Problems Occurring During Storage, Transportation and Measurement.

Although the general precautions for storage and transportation of electronic components can be applied as they are to semiconductor devices, the latter require certain special precautions in addition to these. The following account includes the general precautions.

#### 1.1 Storage of Semiconductor Devices

The following methods of storage are advisable for semiconductor devices. If the precautions are not observed, faults in electrical characteristics, solderability, external appearance and other attributes may occur. In some cases, failure may also result. Precautions for storage are as follows,

- (1) The storage location should be kept within the optimum ranges of temperature and humidity: 5 to 35°C and 45 to 75% R.H. are the optimal conditions.
- (2) The atmosphere in the storage location should not contain any noxious gases, and the amount of dust should be minimal.
- (3) Storage containers should not be susceptible to static electricity.
- (4) Semiconductor devices should not be subjected to loads.
- (5) When stored for long periods, store in the non-processed state. When leads have already been formed, corrosion at their bent portion of leads may occur.
- (6) Be sure that sudden temperature changes sufficient to cause condensation do not occur during storage of the devices.

#### 1.2 Precautions for Transportation

When transporting semiconductor devices or their assembly units or subsystems, the same precautions as for other electronic components should be taken. The items listed in 1.1 and 1.2 have to be followed.

- (1) Transportation containers, jigs etc., should not pick up static charge due to vibration en route.
- (2) Persons handling semiconductor devices should be grounded via a high resistance to discharge any static electricity that may be adhering to their clothing. The resistance value should be around 1 MΩ and no other person should come between the person being discharged and ground (GND).
- (3) When transporting semiconductor devices and PCBs, try to keep mechanical vibration and shocks to an absolute minimum.

## 2. Soldering

### 2.1 SMD Diodes are Formed in Consideration of PCB Mount Ability, and can be Mounted without Modification.

- (1) When mounting on PCB, adhesive is used to temporarily hold diodes in place before solder is applied. When as SMD diodes is held by adhesive, be sure that it is not subjected to undue stress.
- (2) Using a mounter to fix SMD diodes to a PCB can result in bending of the leads, and diode package destroy, so make sure that a force of no more than 3 N is applied and also required to not apply any force on the leads as being mounted, especially for flat package.
- (3) When mounting diodes to circuit board, so make sure that flatten on the PCB. (Not becoming rough by wiring under diode body.)
- (4) Please superfluous power does not join a product by the curvature of a circuit board or bending by circuit board bread etc.
- (5) Since SMD diodes come in small package, be aware of thermal stress from soldering as small as possible. Keep to the following conditions.
  - When flow soldering: 260°C max. for 10 s
  - When using a soldering iron: 350°C max. for 3 s
- (6) The material of lead is exposed for cutting plane. Therefore, soldering nature of lead tip part is considered as unquestioned. Please kindly consider soldering nature.
- (7) When the SMD is mounted through reflow soldering, avoid incorrect positioning and floating-type failures due to bad mounting balance by taking care on the following points.
  - The left and right land patterns must have the same shape.
  - The left and right land areas, including the wiring sections, must take up the same area and include the same amount of solder.
  - The land position should become symmetrical.
  - Heat must be applied to both soldering sections at the same time (the direction shown in follow is recommended).

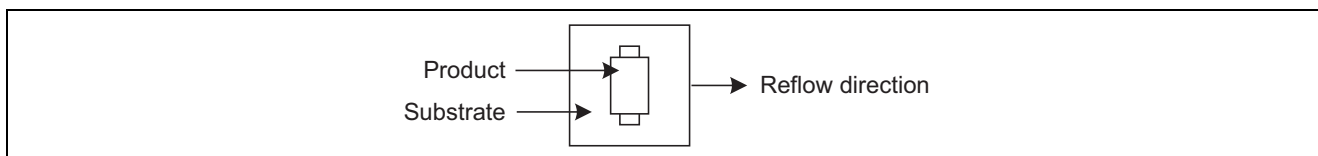

### Soldering Conditions Using Reflow Soldering Method

Lead plating	Sn-Pb / Au / Sn-Bi
Solder paste	Sn-Pb eutectic / Sn-Ag system
Package surface temperature (Upper limit)	Peak temperature: 260°C 220°C or greater for 60 s or less
Temperature profile	<p>Package surface temperature</p> <p>           (1) 110 ± 30 s    (5) 220°C 60 s Max            (2) 160°C        (6) 255°C 16 s Max            (3) 190°C        (7) 260°C Max            (4) 1 to 4°C/s         </p> <p>Reflow cycle: 2 times max.</p> <p>Time</p>

### 3. Cleaning

#### 3.1 Fading of the Marking and Color Codes

Clearness of marking and color-fastness of color codes may be lost due to cleaning.

Be sure to check these after using cleaning agents.

#### 3.2 Electrical and Mechanical Characteristics (Discoloration, Deformation, Denaturation, etc.)

After cleaning a PCB, some corrosive material contained in the cleaning agent or flux may remain on semiconductor devices, causing corrosion of device wiring and leads with resulting loss of reliability.

Thorough cleaning is therefore required for PCBs. It is recommended that level of purity of the PCB after cleaning should conform with the MIL standard below.

##### PCB Level of Purity after Cleaning

Item	Standard
Remaining Cl volume	$\leq 1 \mu\text{g}/\text{cm}^2$
Resistance of solvent (after extraction)	$\geq 2 \times 10^6 \Omega.\text{cm}$

- Notes:
1. PCB surface area: Both sides of the PCB + mounted components.
  2. Extract solvent: Isopropyl alcohol (75 vol%) + H<sub>2</sub>O (25 vol%)  
(Resistance of solvent before extraction is  $\geq 6 \times 10^6 \Omega.\text{cm}$ )
  3. Extraction method: Clean both sides of PCB with 10 ml /  $2.54 \times 2.54 \text{ cm}^2$  (minimum of 1 min.)
  4. Measuring extracted solvent resistance: Conductivity meter

See MIL-P-28809A for details of the MIL standard.

#### 3.3 Ultrasonic Cleaning

It should be avoid resonation of the devices to prevent the device being destroyed.

- SMD
  - Frequency: 28 to 29 kHz (device should not be resonated)
  - Ultrasonic power output: 15 W/1 (1 time)
  - Time: Up to 30 s
  - Others: Make sure that neither devices not PCB come into contact with the vibration source.

Note: To ensure prompt handling of customer queries, the following information should be provided concerning the diode product used;

- (1) Product Name (INT.C)
- (2) Lot No. (LOT)
- (3) Weekly Code (W/C)

Items (1), (2) and (3) above are printed on the label attached to the packing case, reel, etc.

## Renesas Technology Corp. Sales Strategic Planning Div. Nippon Bldg., 2-6-2, Ohte-machi, Chiyoda-ku, Tokyo 100-0004, Japan

### Notes:

- This document is provided for reference purposes only so that Renesas customers may select the appropriate Renesas products for their use. Renesas neither makes warranties or representations with respect to the accuracy or completeness of the information contained in this document nor grants any license to any intellectual property rights or any other rights of Renesas or any third party with respect to the information in this document.
- Renesas shall have no liability for damages or infringement of any intellectual property or other rights arising out of the use of any information in this document, including, but not limited to, product data, diagrams, charts, programs, algorithms, and application circuit examples.
- You should not use the products or the technology described in this document for the purpose of military applications such as the development of weapons of mass destruction or for the purpose of any other military use. When exporting the products or technology described herein, you should follow the applicable export control laws and regulations, and procedures required by such laws and regulations.
- All information included in this document such as product data, diagrams, charts, programs, algorithms, and application circuit examples, is current as of the date this document is issued. Such information, however, is subject to change without any prior notice. Before purchasing or using any Renesas products listed in this document, please confirm the latest product information with a Renesas sales office. Also, please pay regular and careful attention to additional and different information to be disclosed by Renesas such as that disclosed through our website. (<http://www.renesas.com>)
- Renesas has used reasonable care in compiling the information included in this document, but Renesas assumes no liability whatsoever for any damages incurred as a result of errors or omissions in the information included in this document.
- When using or otherwise relying on the information in this document, you should evaluate the information in light of the total system before deciding about the applicability of such information to the intended application. Renesas makes no representations, warranties or guaranties regarding the suitability of its products for any particular application and specifically disclaims any liability arising out of the application and use of the information in this document or Renesas products.
- With the exception of products specified by Renesas as suitable for automobile applications, Renesas products are not designed, manufactured or tested for applications or otherwise in systems the failure or malfunction of which may cause a direct threat to human life or create a risk of human injury or which require especially high quality and reliability such as safety systems, or equipment or systems for transportation and traffic, healthcare, combustion control, aerospace and aeronautics, nuclear power, or undersea communication transmission. If you are considering the use of our products for such purposes, please contact a Renesas sales office beforehand. Renesas shall have no liability for damages arising out of the uses set forth above.
- Notwithstanding the preceding paragraph, you should not use Renesas products for the purposes listed below:
  - artificial life support devices or systems
  - surgical implantations
  - healthcare intervention (e.g., excision, administration of medication, etc.)
  - any other purposes that pose a direct threat to human life
 Renesas shall have no liability for damages arising out of the uses set forth in the above and purchasers who elect to use Renesas products in any of the foregoing applications shall indemnify and hold harmless Renesas Technology Corp., its affiliated companies and their officers, directors, and employees against any and all damages arising out of such applications.
- You should use the products described herein within the range specified by Renesas, especially with respect to the maximum rating, operating supply voltage range, movement power voltage range, heat radiation characteristics, installation and other product characteristics. Renesas shall have no liability for malfunctions or damages arising out of the use of Renesas products beyond such specified ranges.
- Although Renesas endeavors to improve the quality and reliability of its products, IC products have specific characteristics such as the occurrence of failure at a certain rate and malfunctions under certain use conditions. Please be sure to implement safety measures to guard against the possibility of physical injury, and injury or damage caused by fire in the event of the failure of a Renesas product, such as safety design for hardware and software including but not limited to redundancy, fire control and malfunction prevention, appropriate treatment for aging degradation or any other applicable measures. Among others, since the evaluation of microcomputer software alone is very difficult, please evaluate the safety of the final products or system manufactured by you.
- In case Renesas products listed in this document are detached from the products to which the Renesas products are attached or affixed, the risk of accident such as swallowing by infants and small children is very high. You should implement safety measures so that Renesas products may not be easily detached from your products. Renesas shall have no liability for damages arising out of such detachment.
- This document may not be reproduced or duplicated, in any form, in whole or in part, without prior written approval from Renesas.
- Please contact a Renesas sales office if you have any questions regarding the information contained in this document, Renesas semiconductor products, or if you have any other inquiries.



### RENESAS SALES OFFICES

<http://www.renesas.com>

Refer to "<http://www.renesas.com/en/network>" for the latest and detailed information.

#### Renesas Technology America, Inc.

450 Holger Way, San Jose, CA 95134-1368, U.S.A  
Tel: <1> (408) 382-7500, Fax: <1> (408) 382-7501

#### Renesas Technology Europe Limited

Dukes Meadow, Millboard Road, Bourne End, Buckinghamshire, SL8 5FH, U.K.  
Tel: <44> (1628) 585-100, Fax: <44> (1628) 585-900

#### Renesas Technology (Shanghai) Co., Ltd.

Unit 204, 205, AZIACenter, No.1233 Lujiazui Ring Rd, Pudong District, Shanghai, China 200120  
Tel: <86> (21) 5877-1818, Fax: <86> (21) 6887-7898

#### Renesas Technology Hong Kong Ltd.

7th Floor, North Tower, World Finance Centre, Harbour City, 1 Canton Road, Tsimshatsui, Kowloon, Hong Kong  
Tel: <852> 2265-6688, Fax: <852> 2730-6071

#### Renesas Technology Taiwan Co., Ltd.

10th Floor, No.99, Fushing North Road, Taipei, Taiwan  
Tel: <886> (2) 2715-2888, Fax: <886> (2) 2713-2999

#### Renesas Technology Singapore Pte. Ltd.

1 Harbour Front Avenue, #06-10, Keppel Bay Tower, Singapore 098632  
Tel: <65> 6213-0200, Fax: <65> 6278-8001

#### Renesas Technology Korea Co., Ltd.

Kukje Center Bldg. 18th Fl., 191, 2-ka, Hangang-ro, Yongsan-ku, Seoul 140-702, Korea  
Tel: <82> (2) 796-3115, Fax: <82> (2) 796-2145

#### Renesas Technology Malaysia Sdn. Bhd

Unit 906, Block B, Menara Amcorp, Amcorp Trade Centre, No.18, Jalan Persiaran Barat, 46050 Petaling Jaya, Selangor Darul Ehsan, Malaysia  
Tel: <603> 7955-9390, Fax: <603> 7955-9510