



October 1988
Revised February 2000

DM9324 5-Bit Comparator

DM9324 5-Bit Comparator

General Description

The DM9324 expandable comparators provide comparison between two 5-bit words and give three outputs—"less than", "greater than" and "equal to". A HIGH on the active LOW Enable Input forces all three outputs LOW.

Ordering Code:

Order Number	Package Number	Package Description
DM9324N	N16E	16-Lead Plastic Dual-In-Line Package (PDIP), JEDEC MS-001, 0.300 Wide

Logic Symbol

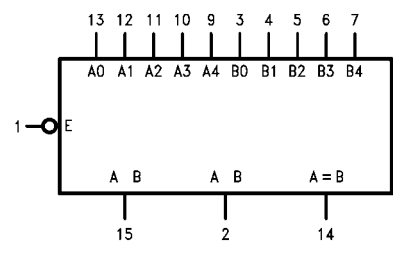

V_{CC} = Pin 16
GND = Pin 6

Connection Diagram

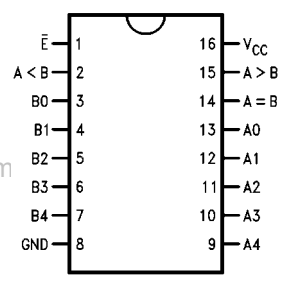

Pin Descriptions

Pin Names	Description
\bar{E}	Enable Input (Active LOW)
A0-A4	Word A Parallel Inputs
B0-B4	Word B Parallel Inputs
A < B	A Less than B Output (Active HIGH)
A > B	A Greater than B Output (Active HIGH)
A = B	A Equal to B Output (Active HIGH)

Truth Table

\bar{E}	Inputs		Outputs		
	A _n	B _n	A < B	A > B	A = B
H	X	X	L	L	L
L	Word A = Word B		L	L	H
L	Word A > Word B		L	H	L
L	Word B > Word A		H	L	L

H = HIGH Voltage Level
L = LOW Voltage Level
X = Immaterial

DM9324

Functional Description

The '24 5-bit comparators use combinational circuitry to directly generate "A greater than B" and "A less than B" outputs. As evident from the logic diagram, these outputs are generated in only three gate delays. The "A equals B" output is generated in one additional gate delay by decoding the "A neither less than nor greater than B" condition with a NOR gate. All three outputs are activated by the active LOW Enable Input (\bar{E}).

Tying the A > B output from one device into an A input on another device and the A < B output into the corresponding B input permits easy expansion.

The A4 and B4 inputs are the most significant inputs and A0, B0 the least significant. Thus if A4 is HIGH and B4 is LOW, the A > B output will be HIGH regardless of all other inputs except \bar{E} .

Logic Diagram

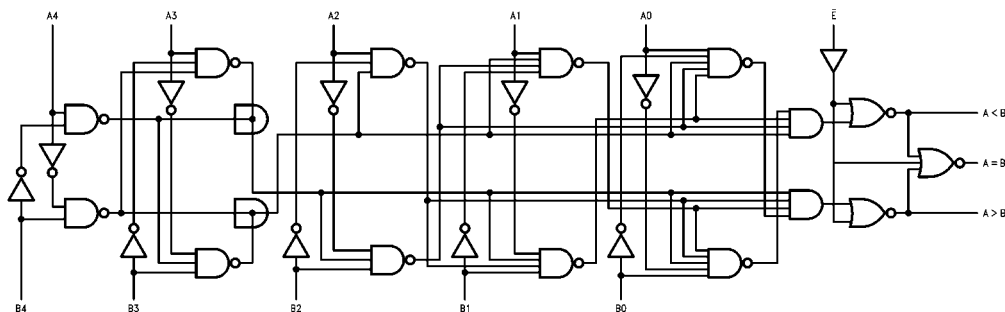

Absolute Maximum Ratings(Note 1)

Supply Voltage	7V
Input Voltage	5.5V
Operating Free Air Temperature Range	0°C to +70°C
Storage Temperature Range	-65°C to +150°C

Note 1: The "Absolute Maximum Ratings" are those values beyond which the safety of the device cannot be guaranteed. The device should not be operated at these limits. The parametric values defined in the Electrical Characteristics tables are not guaranteed at the absolute maximum ratings. The "Recommended Operating Conditions" table will define the conditions for actual device operation.

Recommended Operating Conditions

Symbol	Parameter	Min	Nom	Max	Units
V_{CC}	Supply Voltage	4.75	5	5.25	V
V_{IH}	HIGH Level Input Voltage	2			V
V_{IL}	LOW Level Input Voltage			0.8	V
I_{OH}	HIGH Level Output Current			-0.8	mA
I_{OL}	LOW Level Output Current			16	mA
T_A	Free Air Operating Temperature	0		70	°C

Electrical Characteristics

Over recommended operating free air temperature range (unless otherwise noted)

Symbol	Parameter	Conditions	Min	Typ (Note 2)	Max	Units
V_I	Input Clamp Voltage	$V_{CC} = \text{Min}, I_I = -12 \text{ mA}$			-1.5	V
V_{OH}	HIGH Level Output Voltage	$V_{CC} = \text{Min}, I_{OH} = \text{Max}$ $V_{IL} = \text{Max}$	2.4	3.4		V
V_{OL}	LOW Level Output Voltage	$V_{CC} = \text{Min}, I_{OL} = \text{Max}$ $V_{IH} = \text{Min}$		0.2	0.4	V
I_I	Input Current @ Max Input Voltage	$V_{CC} = \text{Max}, V_I = 5.5\text{V}$			1	mA
I_{IH}	HIGH Level Input Current	$V_{CC} = \text{Max}, V_I = 2.4\text{V}$			80	μA
I_{IL}	LOW Level Input Current	$V_{CC} = \text{Max}, V_I = 0.4\text{V}$			-3.2	mA
I_{OS}	Short Circuit Output Current	$V_{CC} = \text{Max}$ (Note 3)	-20		-70	mA
I_{CC}	Supply Current	$V_{CC} = \text{Max}$			81	mA

Note 2: All typicals are at $V_{CC} = 5\text{V}, T_A = 25^\circ\text{C}$.

Note 3: Not more than one output should be shorted at a time.

Switching Characteristics

$V_{CC} = +5.0\text{V}, T_A = +25^\circ\text{C}$

Symbol	Parameter	$C_L = 15 \text{ pF}$		Units
		Min	Max	
t_{PLH}	Propagation Delay		14	ns
t_{PHL}	\bar{E} to A = B		14	
t_{PLH}	Propagation Delay		25	ns
t_{PHL}	A_n, B_n to A > B		22	
t_{PLH}	Propagation Delay		26	ns
t_{PHL}	A_n, B_n to A < B		21	
t_{PLH}	Propagation Delay		30	ns
t_{PHL}	A_n, B_n to A = B		32	

Physical Dimensions inches (millimeters) unless otherwise noted

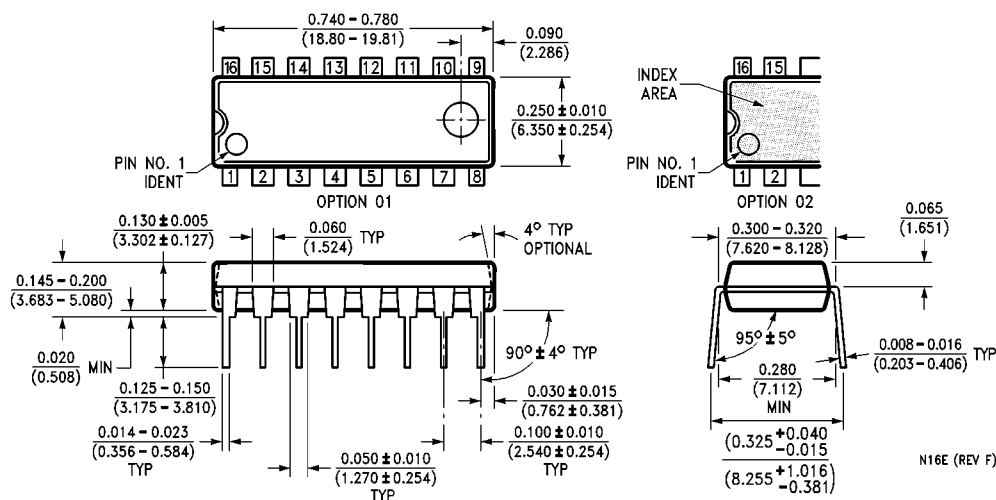

16-Lead Plastic Dual-In-Line Package (PDIP), JEDEC MS-001, 0.300 Wide
Package Number N16E

DataSheet4U.com

Fairchild does not assume any responsibility for use of any circuitry described, no circuit patent licenses are implied and Fairchild reserves the right at any time without notice to change said circuitry and specifications.

LIFE SUPPORT POLICY

FAIRCHILD'S PRODUCTS ARE NOT AUTHORIZED FOR USE AS CRITICAL COMPONENTS IN LIFE SUPPORT DEVICES OR SYSTEMS WITHOUT THE EXPRESS WRITTEN APPROVAL OF THE PRESIDENT OF FAIRCHILD SEMICONDUCTOR CORPORATION. As used herein:

1. Life support devices or systems are devices or systems which, (a) are intended for surgical implant into the body, or (b) support or sustain life, and (c) whose failure to perform when properly used in accordance with instructions for use provided in the labeling, can be reasonably expected to result in a significant injury to the user.
2. A critical component in any component of a life support device or system whose failure to perform can be reasonably expected to cause the failure of the life support device or system, or to affect its safety or effectiveness.

www.fairchildsemi.com