

TO-220 • TO-220FP • TO-220FN • HRT

TO-220FP is a TO-220 with mold coated fin for easier mounting and higher PC, 2W. TO-220FN is a low profile (by 2mm) version of TO-220FP without fin support pin, for higher mounting density. HRT is a taped power transistor package for use with an automatic placement machine.

Application	Part No.				V _{CEO} (V)	I _C (A)	P _C (W)				h _{FE}	h _{FE} Ranking code	V _{CE} (V)	I _C (A)	Internal circuit
	TO-220	TO-220FP	TO-220FN	HRT			T _C =25°C		T _a =25°C						
							TO-220	TO-220FP	TO-220FN	HRT					
Driver	2SA1634	2SA1635	-	-	-60	-4	40	30	-	-	60~320	D E F	-4	-1	-
	2SB1369	2SB1370	2SB1565	2SB1496	-60	-3	40	30	25	1.8	60~320	D E F	-5	-0.5	-
	2SB1064	2SB1185	2SB1566	2SB1357	-50	-3	30	25	25	1.8	60~320	D E F	-3	-0.5	-
	2SB1085	2SB1186	2SB1569	2SB1353	-120	-1.5	20	20	20	1.8	60~320	D E F	-5	-0.1	-
	2SB1085A	2SB1186A	2SB1569A	2SB1353A	-160	-1.5	20	20	20	1.8	60~200	D E	-5	-0.1	-
	2SB1289	2SB1290	-	2SB1356	-80	-7	40	30	-	1.8	60~320	D E F	-5	-1	-
	2SB1291	2SB1292	-	2SB1358	-60	-5	40	30	-	1.8	60~320	D E F	-5	-1	-
	2SB1293	2SB1294	-	2SB1360	-100	-5	40	30	-	1.8	60~320	D E F	-5	-1	-
	2SB1334	2SB1335	-	2SB1355	-60	-4	40	30	-	1.8	60~320	D E F	-5	-1	-
	2SB1334A	2SB1335A	-	-	-80	-4	40	30	-	-	60~320	D E F	-5	-1	-
	2SC4007	2SC4008	-	2SC4355	80	4	40	30	-	1.8	60~500	D E F G	4	1	-
	2SD2023	2SD2061	2SD2394	2SD2096	60	3	40	30	25	1.8	60~320	D E F	5	0.5	-
	2SD1505	2SD1762	2SD2395	2SD2037	50	3	30	25	25	1.8	60~320	D E F	3	0.5	-
	2SD1562	2SD1763	2SD2400	2SD2033	120	1.5	20	20	20	1.8	60~320	D E F	5	0.1	-
	2SD1562A	2SD1763A	2SD2400A	2SD2033A	160	1.5	20	20	20	1.8	60~200	D E	5	0.1	-
	2SD1580	2SD1833	-	2SD2036	80	7	40	30	-	1.8	60~320	D E F	5	1	-
	2SD1720	2SD1832	-	2SD2038	60	5	40	30	-	1.8	60~320	D E F	5	1	-
	2SD1778	2SD1855	-	2SD2035	60	4	40	30	-	1.8	60~320	D E F	5	1	-
	2SD1778A	2SD1855A	-	-	80	4	40	30	-	-	60~320	D E F	5	1	-
	2SD1896	2SD1897	-	2SD2040	100	5	40	30	-	1.8	60~320	D E F	5	1	-
2SD1956	2SD1957	-	-	120	7	40	30	-	-	100~500	E F G	5	1	-	
Low V _{CE(sat)}	-	2SA1757	-	-	-60	-5	-	25	-	-	60~320	D E F	-2	-1	-
	-	2SA1758	-	-	-60	-12	-	30	-	-	60~320	D E F	-2	-2	-
	-	2SC4595	-	-	60	12	-	30	-	-	60~320	D E F	2	2	-
	-	2SC4596	-	-	60	5	-	25	-	-	60~320	D E F	2	1	-
	2SC4845	2SC4846	-	-	120	5	40	30	-	-	60~200	D E	5	3	-
2SC4848	2SC4849	-	-	120	7	40	30	-	-	60~200	D E	5	3	-	
Chroma	-	-	2SC5147	2SC4506	300	0.1	-	-	10	1.5	40~200	C D E	10	0.01	-
High h _{FE}	2SD1943	2SD1944	2SD2396	2SD2044	60	3	40	30	30	1.8	400~2k	H J K	4	0.5	-
High Voltage SW	2SC3968	2SC3969	-	2SC4354	400	2	20	20	-	1.8	16~50	A B	5	0.1	-
	2SC4205	2SC4129	-	-	400	5	40	30	-	-	16~32	A	5	3	-
	☆2SC5112	☆2SC5113	-	-	500	5	40	35	-	-	10~50	-	5	2.5	-
	☆2SC5116	☆2SC5117	-	-	550	4	40	35	-	-	10~50	-	5	2	-
Darlington	2SB1286	2SB1287	2SB1567	2SB1359	-100	-2	25	20	20	1.8	1k~10k	-	-2	-1	Fig.1
	2SB1339	2SB1340	-	2SB1513	-120	-6	40	30	-	1.8	2k~20k	-	-3	-2	Fig.1
	2SB1341	2SB1342	2SB1568	2SB1512	-80	-4	35	30	30	1.8	1k~10k	-	-3	-2	Fig.1
	2SB1343	2SB1344	-	2SB1514	-100	-8	40	30	-	1.8	1k~20k	-	-3	-2	Fig.1
	2SB1550	2SB1551	-	2SB1549	-80	-10	40	30	-	1.8	1k~20k	-	-3	-5	Fig.1
	-	2SB1616	-	-	-80	-4	-	30	-	-	1K~10K	-	-3	-2	Fig.5
	2SC4573	2SC4574	-	2SC4575	60±10	4	35	30	-	1.8	2k~10k	-	5	1.5	Fig.4
	-	2SC4895	-	-	100	3	-	30	-	-	2k~10k	-	2	1.5	Fig.2
	2SD1646	2SD1765	2SD2398	2SD2039	100	2	25	20	20	1.8	1k~10k	-	2	1	Fig.2
	2SD1647	2SD1764	2SD2397	2SD2041	60±10	2	25	20	20	1.8	1k~10k	-	2	1	Fig.4
	-	2SD2091	-	2SD2283	90 ⁺²⁰ ₋₁₀	2	-	20	-	1.8	1k~10k	-	2	1	Fig.4
	2SD1783	2SD1856	-	2SD2042	60±10	5	30	25	-	1.8	2k~30k	-	3	2	Fig.4
	2SD1888	2SD1889	-	2SD2043	120	6	40	30	-	1.8	2k~20k	-	3	2	Fig.2
	2SD1932	2SD1933	2SD2399	2SD2032	80	4	35	30	30	1.8	1k~10k	-	3	2	Fig.2
	2SD1986	2SD1987	-	2SD2306	60	4	35	30	-	1.8	1k~10k	-	3	2	Fig.3
2SD2024	2SD2025	-	2SD2307	100	8	40	30	-	1.8	1k~20k	-	3	2	Fig.2	

Note : ☆Under development

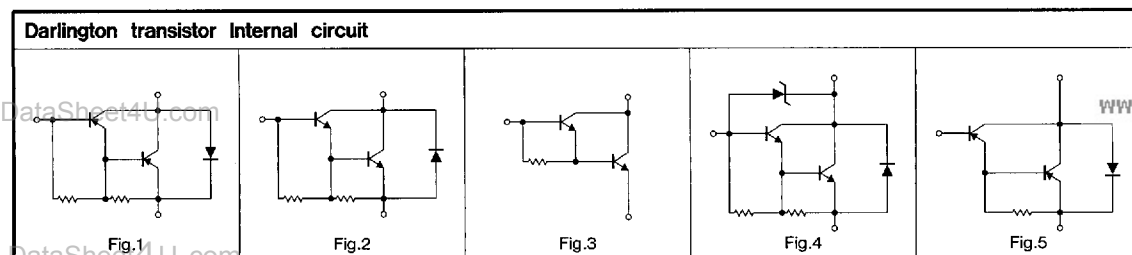

●Product Designation

- When ordering, specify the type.
- Check each code against the tables shown below.
- Fill a space with the next character.

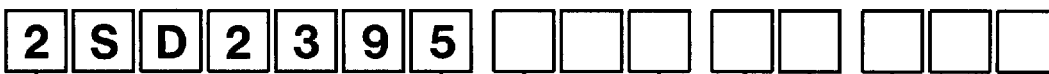

Part No.

Special code

- Omit for standard product.
- Factory assigned for custom product.

Packaging

Package	Code	Package specifications	Quantity /Package (pcs)
TO-220*	None	Bulk	500
	C7	Tube	1,000 (50pcs × 20)
TO-220FP*	None	Bulk	500
	C7	Tube	1,000 (50pcs × 20)
TO-220FN	None	Bulk	500
	C7	Tube	1,000 (50pcs × 20)
HRT	T114	Ammo box	1,000

Note : Available in various lead configurations (forming, cut leads) .
For further information , contact our sales representatives .

hFE Ranking code

Input hFE rank signal display
One rank preferred D
Multiple rank preferred D F
(Min., Max. is displayed)

Code	hFE Range
A	16~32
B	25~50
C	40~80
D	60~120
E	100~200
F	160~320
G	250~500
H	400~800
J	600~1200
K	1000~2000

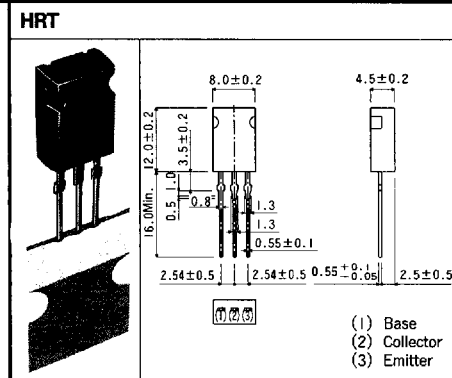
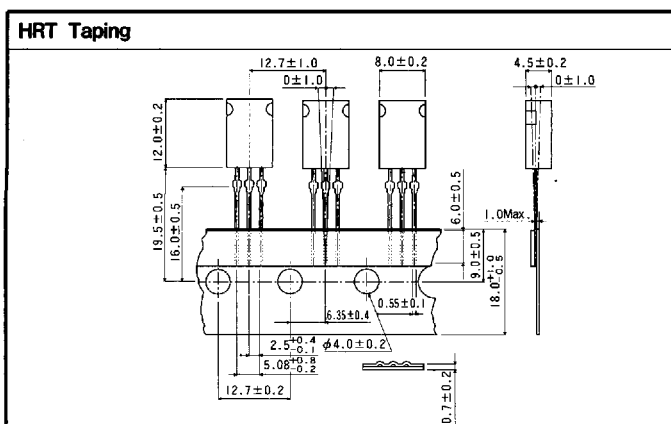
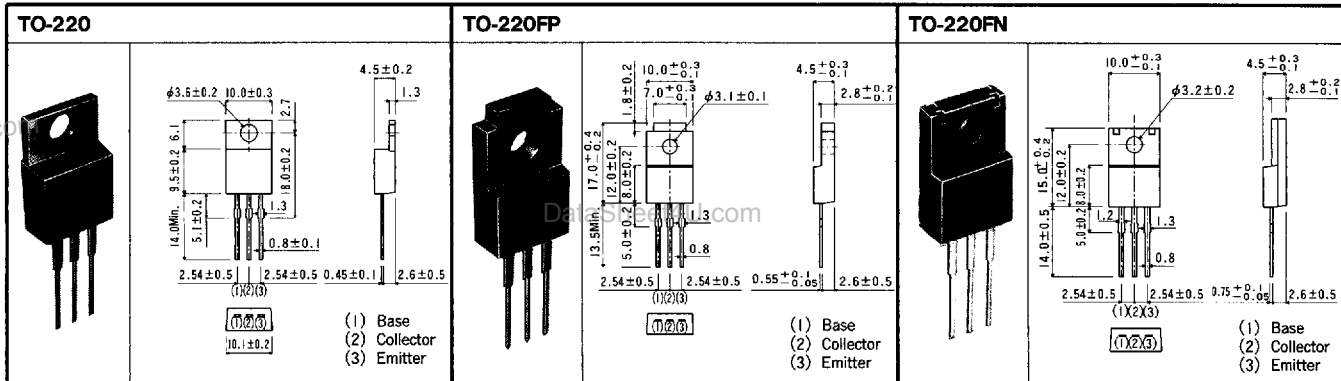

(Unit : mm)

HRT Ammo box

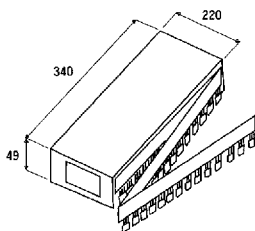

TO-220 Container tube

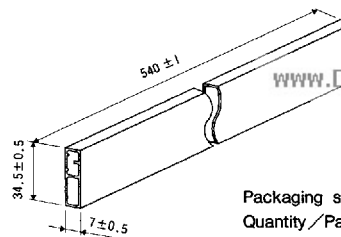

www.DataSheet4U.com
Packaging specification code : C7
Quantity /Packaging : 50 pcs