



Gated-Class H, Dual-Port VDSL2 Line Driver

 Check for Samples: [THS6226](#)

FEATURES

- **Digitally-Adjustable Quiescent Current:** 7.6mA to 23.0mA
- **1.0mA Bias Current Step**
- **Independent Voltage Boost and Main Line Driver Disable**
- **Low-Power Line Termination Mode**
- **Full Capacitor Recharge: 3ms**
- **Low Input Voltage Noise Density:** 6.3 nV/ $\sqrt{\text{Hz}}$ Input-Referred Voltage Noise
- **Low MTPR Distortion:** 70dB with +19.8dBm G.993.2—Profile 8b
- **–91dBc HD3 (1MHz, 60 Ω Differential)**
- **High Output Current: (383mA into 60 Ω)**
- **Wide Output Swing: 40V_{PP} (+12V, 60 Ω Differential Load with a 1:1.4 Transformer)**
- **Wide Bandwidth: 125MHz**
- **Port-to-Port Separation of 90dB at 1MHz**
- **PSRR: 70dB at 1MHz for Good Isolation**

APPLICATIONS

- **Ideal for All VDSL2 Profiles**
- **Backwards-Compatible with ADSL/ADSL2+/ADSL2++ Systems**

DESCRIPTION

The THS6226 is a dual-port, class H, current-feedback architecture, differential line driver amplifier system ideal for xDSL systems. The device is targeted for use in very-high-bit-rate digital subscriber line 2 (VDSL2) line driver systems that enable native DTM signals while supporting greater than +20.5dBm line power (up to 8.5MHz) with good linearity, supporting the G.993.2 VDSL2 8b profile. It is also fast enough to support central-office transmission of +14.5dBm line power up to 30MHz.

The unique architecture of the THS6226 allows quiescent current to be minimal while still achieving very high linearity. Differential distortion, under full bias conditions, is –91dBc at 1MHz and reduces to only –75dBc at 5MHz. Fixed multiple bias settings of the amplifiers offer enhanced power savings for line lengths where the full performance of the amplifier is not required. To allow for even more flexibility and power savings on all profiles, quiescent current is digitally adjustable from 7.6mA to 23mA with a bias current step of 1.0mA. For systems where additional power savings while not transmitting are desired, the THS6226 can be used in its line termination mode to maintain impedance matching.

The wide output swing on +12V power supplies, coupled with excellent current drive, allows for wide dynamic headroom, keeping distortion minimal.

The THS6226 is available in a QFN-32 PowerPAD™ package.

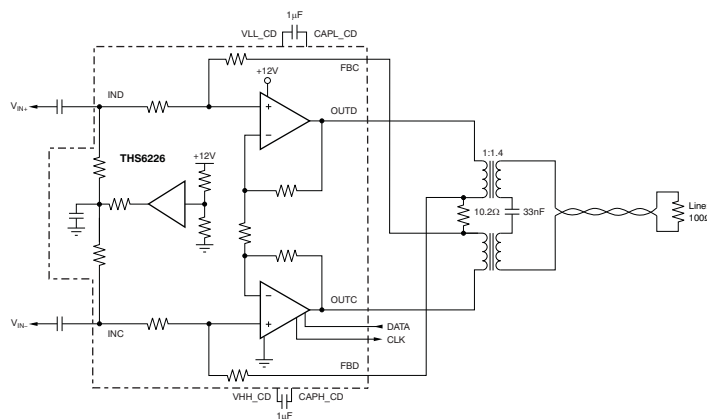

Typical VDSL2 Line Driver Circuit Using One Port of the THS6226



Please be aware that an important notice concerning availability, standard warranty, and use in critical applications of Texas Instruments semiconductor products and disclaimers thereto appears at the end of this data sheet.

PowerPAD is a trademark of Texas Instruments, Inc.

All other trademarks are the property of their respective owners.



This integrated circuit can be damaged by ESD. Texas Instruments recommends that all integrated circuits be handled with appropriate precautions. Failure to observe proper handling and installation procedures can cause damage.

ESD damage can range from subtle performance degradation to complete device failure. Precision integrated circuits may be more susceptible to damage because very small parametric changes could cause the device not to meet its published specifications.

ORDERING INFORMATION⁽¹⁾

PRODUCT ⁽²⁾	PACKAGE-LEAD	PACKAGE DESIGNATOR	PACKAGE MARKING	TRANSPORT MEDIA, QUANTITY
THS6226IRHBT	VQFN-32	RHB	THS6226IRHB	Tape and Reel, 250
THS6226IRHBR				Tape and Reel, 3000

(1) For the most current package and ordering information, see the Package Option Addendum at the end of this document, or visit the device product folder at www.ti.com.

(2) The PowerPAD is electrically isolated from all other pins.

ABSOLUTE MAXIMUM RATINGS⁽¹⁾

Over operating free-air temperature range, unless otherwise noted.

PARAMETER		THS6226	UNIT
Supply voltage, GND to V_{S+} , class AB only		15	V
Supply voltage, GND to V_{S+} , class H only		12.5	V
Input voltage, V_I		15	V
Output current, I_O : static dc ⁽²⁾		±100	mA
Continuous power dissipation		See Thermal Information table	
Normal storage temperature		–40 to +85	°C
Maximum junction temperature, any condition, T_J ⁽³⁾		+150	°C
Maximum junction temperature, continuous operation, long-term reliability, T_J ⁽⁴⁾		+130	°C
Storage temperature range, T_{STG}		–65 to +150	°C
ESD ratings:	Human body model (HBM)	2000	V
	Charged device model (CDM)	500	V
	Machine model (MM)	100	V

(1) Stresses above those listed under *absolute maximum ratings* may cause permanent damage to the device. These are stress ratings only, and functional operation of the device at these or any other conditions beyond those indicated under *recommended operating conditions* is not implied. Exposure to absolute maximum rated conditions for extended periods may degrade device reliability.

(2) The THS6226 incorporates a PowerPAD on the underside of the chip. This acts as a heatsink and must be connected to a thermally dissipating plane for proper power dissipation. Failure to do so may result in exceeding the maximum junction temperature which could permanently damage the device. See TI Technical Brief [SLMA002](#) for more information about utilizing the PowerPAD thermally-enhanced package. Under high-frequency ac operation (> 10kHz), the short-term output current capability is much greater than the continuous dc output current rating. This short-term output current rating is about 8.5x the dc capability, or approximately ±850mA.

(3) The absolute maximum junction temperature under any condition is limited by the constraints of the silicon process.

(4) The absolute maximum junction temperature for continuous operation is limited by the package constraints. Operation above this temperature may result in reduced reliability and/or lifetime of the device.

THERMAL INFORMATION

THERMAL METRIC ⁽¹⁾		THS6226	UNITS
		RHB	
		32 PINS	
θ_{JA}	Junction-to-ambient thermal resistance	35.1	°C/W
θ_{JCTop}	Junction-to-case (top) thermal resistance	22.1	
θ_{JB}	Junction-to-board thermal resistance	7.0	
Ψ_{JT}	Junction-to-top characterization parameter	0.3	
Ψ_{JB}	Junction-to-board characterization parameter	6.9	
θ_{JCbott}	Junction-to-case (bottom) thermal resistance	1.3	

(1) For more information about traditional and new thermal metrics, see the *IC Package Thermal Metrics* application report, [SPRA953](#).

ELECTRICAL CHARACTERISTICS: $V_S = +12V$
Boldface limits are tested at **+25°C**.

 At $T_A = +25^\circ\text{C}$, with $R_{MATCH} = 10.2\Omega$, transformer turn ratio 1:1.4, $R_L = 100\Omega$ differential at transformer output, Full Bias Mode, and active impedance circuit configuration, unless otherwise noted. Each port is tested independently.

PARAMETER	CONDITIONS	THS6226IRHB			UNIT	TEST LEVEL ⁽¹⁾
		MIN	TYP	MAX		
AC PERFORMANCE						
Small-signal bandwidth, –3dB	$V_O = 2V_{PP}$, differential at OUTCD and OUTAB, gain = 19V/V		125		MHz	C
0.1dB bandwidth flatness	$V_O = 2V_{PP}$		37		MHz	C
Large-signal bandwidth	$V_O = 10V_{PP}$		125		MHz	C
Slew rate (10% to 90% level)	$V_O = 15V$ step, differential		1500		V/ μs	C
Rise and fall time	$V_O = 2V_{PP}$		2.8		ns	C
Harmonic distortion	$V_O = 2V_{PP}$, $R_L = 60\Omega$ differential					C
Second harmonic	Full bias, $f = 1\text{MHz}$		–91		dBc	C
Third harmonic	Full bias, $f = 1\text{MHz}$		–91		dBc	C
Second harmonic	Full bias, $f = 5\text{MHz}$		–70		dBc	C
	Low bias, $f = 5\text{MHz}$		–64		dBc	C
Third harmonic	Full bias, $f = 5\text{MHz}$		–75		dBc	C
	Low bias, $f = 5\text{MHz}$		–47		dBc	C
Differential input voltage noise	$f = 1\text{MHz}$, input-referred		6.3		nV/ $\sqrt{\text{Hz}}$	C
DC PERFORMANCE						
Differential gain			19		V/V	C
Differential gain error ⁽²⁾				± 2.5	%	A
Input offset voltage			± 1	± 5	mV	A
	–40°C to +85°C			± 6	mV	B
Input offset voltage drift				15	$\mu\text{V}/^\circ\text{C}$	B
Input offset voltage matching	Channels 1 to 2 and 3 to 4 only		± 1	± 5	mV	A
INPUT CHARACTERISTICS						
Noninverting input resistance			500 2		k Ω pF	C
Input bias voltage		5.8	6	6.2	V	A
OUTPUT CHARACTERISTICS						
Class H output voltage swing	$R_L = 60\Omega$ differential, class H operation ⁽³⁾⁽⁴⁾ , each output	+16/–4	+17.5/–5.5		V	A
	–40°C to +85°C ⁽³⁾⁽⁴⁾	+15.7/–3.7			V	B
Class H output current (sourcing, sinking)	$R_L = 60\Omega$ differential, class H operation	± 333	± 383		mA	A
	–40°C to +85°C	± 323			mA	B
Class AB output voltage swing	$R_L = 60\Omega$ differential, normal operation ⁽³⁾ , each output	+9.9/+2.1	+10.1/+1.9		V	A
	–40°C to +85°C ⁽³⁾	+9.8/+2.2			V	B
Class AB output current (sourcing, sinking)	$R_L = 60\Omega$ differential, normal operation	± 130	± 137		mA	A
	–40°C to +85°C	± 126			mA	B
Short-circuit output current			1		A	C
Output impedance	$f = 1\text{MHz}$, differential		0.2		Ω	C
Crosstalk	$f = 1\text{MHz}$, $V_{OUT} = 2V_{PP}$, port 1 to port 2		–90		dB	C

- (1) Test levels: **(A)** 100% tested at +25°C. Over temperature limits set by characterization and simulation. **(B)** Limits set by characterization and simulation. **(C)** Typical value only for information.
- (2) Negative feedback loop only.
- (3) Measured at amplifier output (pin 17, 20, 21, and 24).
- (4) Capacitor fully charged, no droop.

ELECTRICAL CHARACTERISTICS: $V_S = +12V$ (continued)
Boldface limits are tested at **+25°C**.

 At $T_A = +25^\circ\text{C}$, with $R_{MATCH} = 10.2\Omega$, transformer turn ratio 1:1.4, $R_L = 100\Omega$ differential at transformer output, Full Bias Mode, and active impedance circuit configuration, unless otherwise noted. Each port is tested independently.

PARAMETER	CONDITIONS	THS6226IRHB			UNIT	TEST LEVEL ⁽¹⁾
		MIN	TYP	MAX		
POWER SUPPLY						
Maximum operating voltage	Class AB	+10	+12	+15	V	A
	–40°C to +85°C	+10		+15	V	B
	Class H	+10	+12	+12.5	V	B
	–40°C to +85°C	+10		+12.5		B
I_{S+} quiescent current	Per port, full bias, class H enable (power supply connected together)	22.5	23.5	24.5	mA	A
	–40°C to +85°C	21.8		25.2	mA	B
	Per port, full bias, class H disable (power supply connected together)	22.0	23.0	24.0	mA	A
	–40°C to +85°C	21.3		24.7	mA	B
	Bias current step		1.0		mA	C
	Per port, low bias, class H disable (power supply connected together)	7.2	7.6	8	mA	A
	–40°C to +85°C	6.9		8.3	mA	B
	Per port, line termination mode (B9 = B8 = B7 = B6 = 0) (power supply connected together)		4.4		mA	C
Power-supply rejection (PSRR)	Both ports, main amplifiers and class H disable (B9 = B8 = B7 = B6 = 0)		1.7	2.2	mA	A
	–40°C to +85°C			2.3	mA	B
	Differential, from +12V, GND	60	70		dB	A
	–40°C to +85°C	58			dB	B
LOGIC						
Logic pin logic threshold	Logic 1, with respect to GND ⁽⁵⁾	1.9			V	C
	Logic 0, with respect to GND ⁽⁵⁾			0.8	V	C
Logic pin quiescent current	Logic X = 0.5V (logic 0)		10	25	μA	A
	–40°C to +85°C			30	μA	B
	Logic X = 3.3V (logic 1)		66	125	μA	A
	–40°C to +85°C			130	μA	B
Turn-on time delay (t_{ON})	Time for I_S to reach 50% of final value		1		μs	C
Turn-off time delay (t_{OFF})	Time for I_S to reach 50% of final value		1		μs	C
Logic pin input impedance			50 1		k Ω pF	C

 (5) The GND pin usable range is from V_{S-} to $(V_{S+} - 5V)$.

PIN DESCRIPTIONS

NAME	PIN	DESCRIPTION
GND	1	Analog ground
IND	2	Input D of amplifier CD
INC	3	Input C of amplifier CD
DATA	4	Serial interface data pin
CLK	5	Serial interface CLK pin
INB	6	Input B of amplifier AB
INA	7	Input A of amplifier AB
GND	8	Analog ground
V _{H_ENAB}	9	Class H mode control pin for amplifier AB
VLL_AB	10	Amplifier AB low pump supply
CAPL_AB	11	Amplifier AB negative voltage pump capacitor pin
GND	12	Analog ground
V _S AB	13	Amplifier AB supply voltage
V _S AB	14	Amplifier AB supply voltage
CAPH_AB	15	Amplifier AB positive voltage pump capacitor pin
VHH_AB	16	Amplifier AB high pump supply
OUTA	17	Output A of amplifier AB
FB_A	18	Feedback for active output impedance of amplifier AB
FB_B	19	Feedback for active output impedance of amplifier AB
OUTB	20	Output B of amplifier AB
OUTC	21	Output C of amplifier CD
FB_C	22	Feedback for active output impedance of amplifier CD
FB_D	23	Feedback for active output impedance of amplifier CD
OUTD	24	Output D of amplifier CD
VHH_CD	25	Amplifier CD high pump supply
CAPH_CD	26	Amplifier CD positive voltage pump capacitor pin
V _S CD	27	Amplifier CD supply voltage
V _S CD	28	Amplifier CD supply voltage
GND	29	Analog ground
CAPL_CD	30	Amplifier CD negative voltage pump capacitor pin
VLL_CD	31	Amplifier CD low pump supply
V _{H_ENCD}	32	Class H mode control pin for amplifier CD

TIMING CHARACTERISTICS

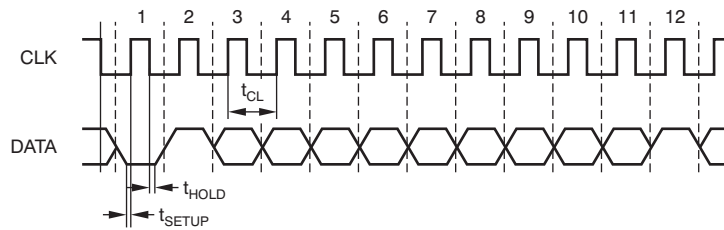

Figure 1. Serial Interface Timing

PARAMETER	DESCRIPTION	THS6226		UNITS
		MIN	MAX	
t_{SETUP}	Setup time	3		ns
t_{HOLD}	Hold time	0.5		ns
t_{CL}	Clock period	200		ns

TYPICAL CHARACTERISTICS: $V_S = +12V$

At $T_A = +25^\circ C$ and Full Bias Mode, unless otherwise noted

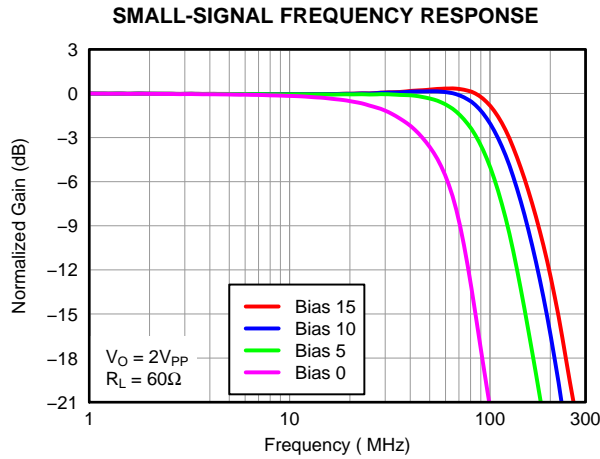

Figure 2.

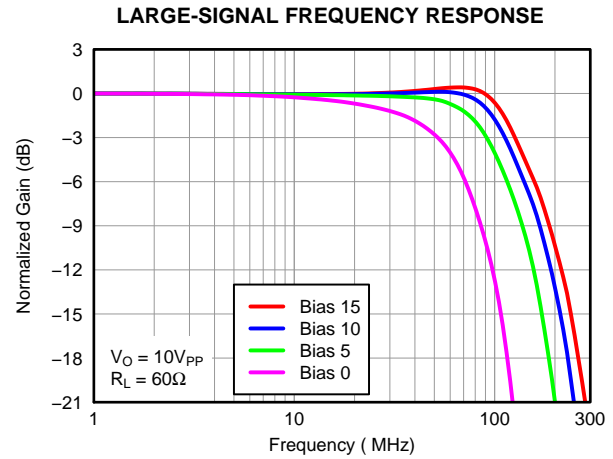

Figure 3.

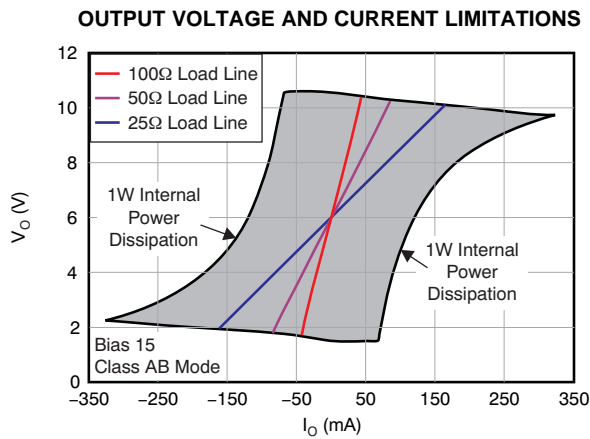

Figure 4.

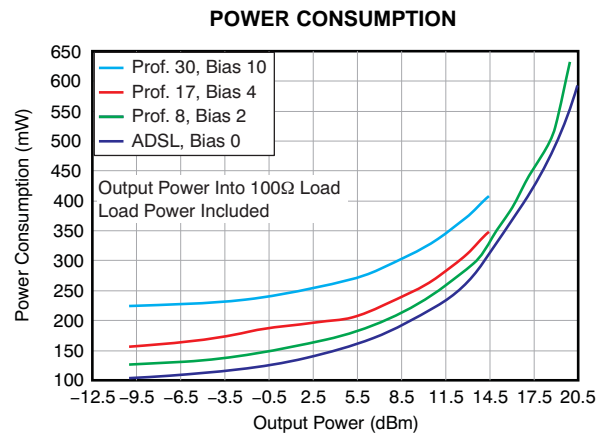

Figure 5.

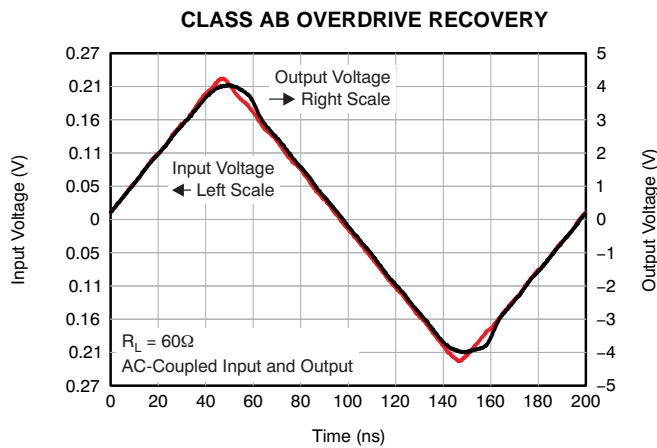

Figure 6.

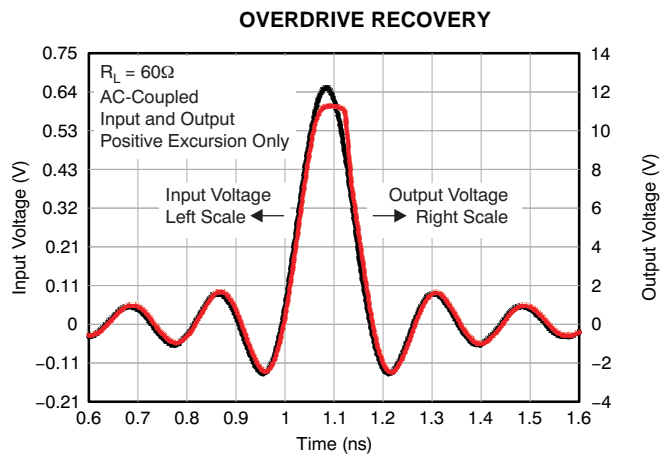

Figure 7.

TYPICAL CHARACTERISTICS: $V_S = +12V$ (continued)

At $T_A = +25^\circ C$ and Full Bias Mode, unless otherwise noted

INPUT NOISE DENSITY

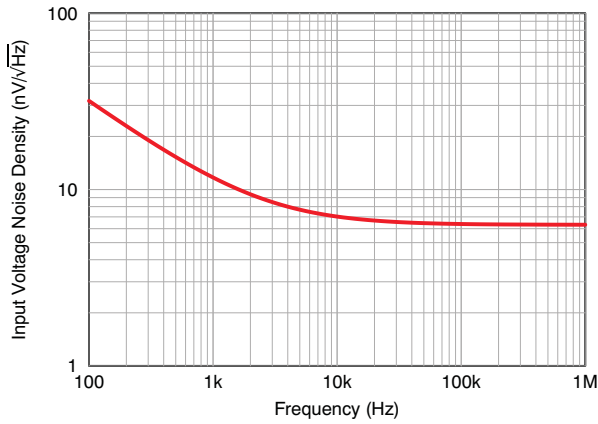

Figure 8.

HARMONIC DISTORTION vs FREQUENCY

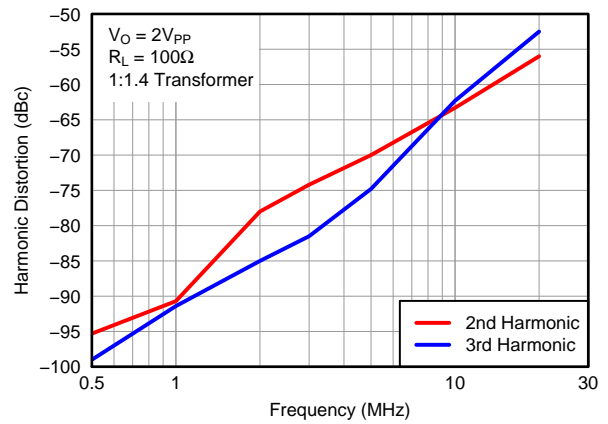

Figure 9.

HARMONIC DISTORTION vs LOAD

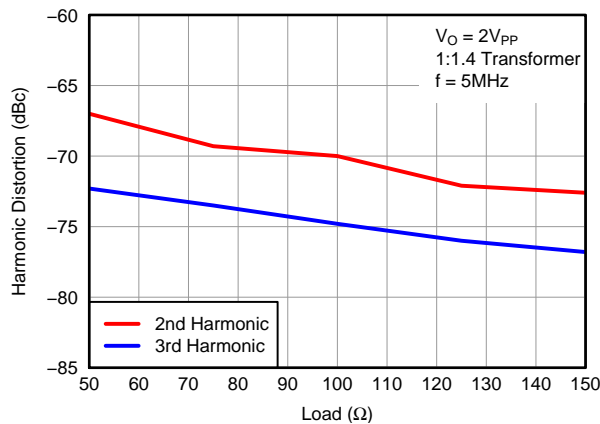

Figure 10.

TWO-TONE, THIRD-ORDER INTERMODULATION SPURIOUS

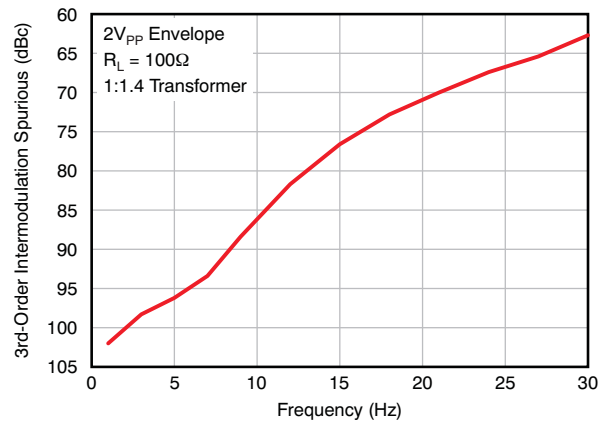

Figure 11.

HARMONIC DISTORTION vs OUTPUT VOLTAGE

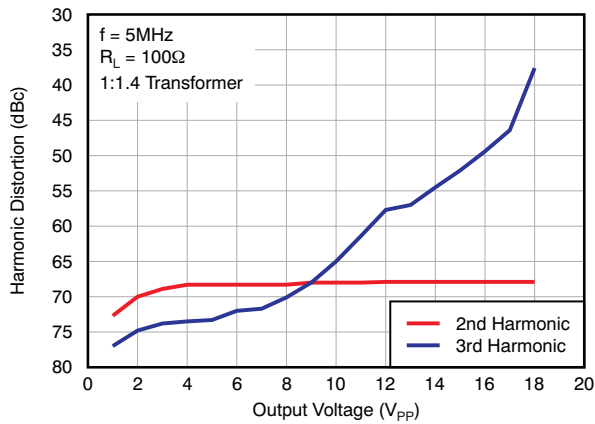

Figure 12.

HARMONIC DISTORTION vs BIAS CURRENT

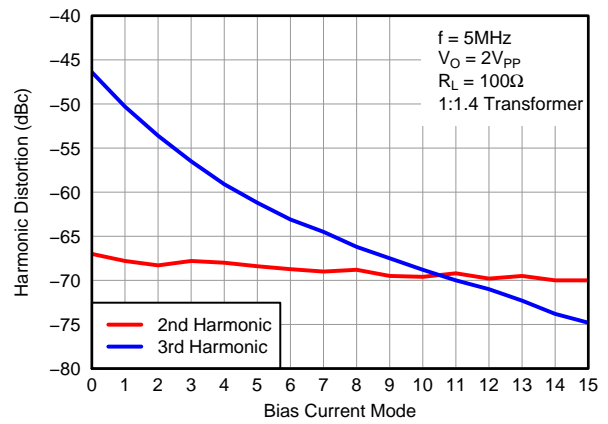

Figure 13.

TYPICAL CHARACTERISTICS: $V_S = +12V$ (continued)

At $T_A = +25^\circ C$ and Full Bias Mode, unless otherwise noted

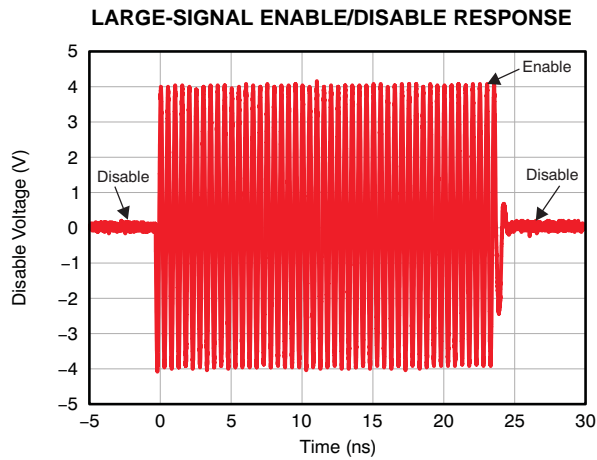

Figure 14.

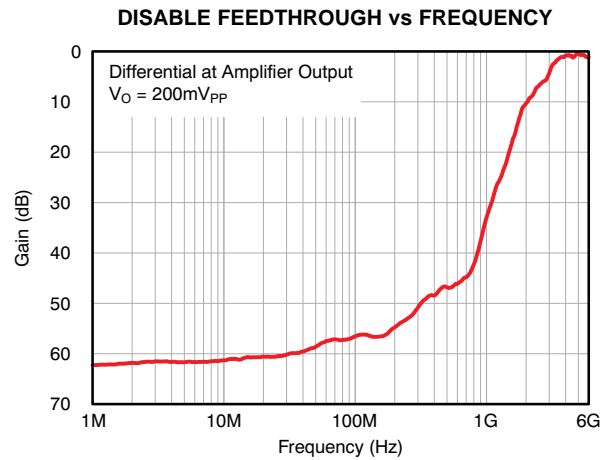

Figure 15.

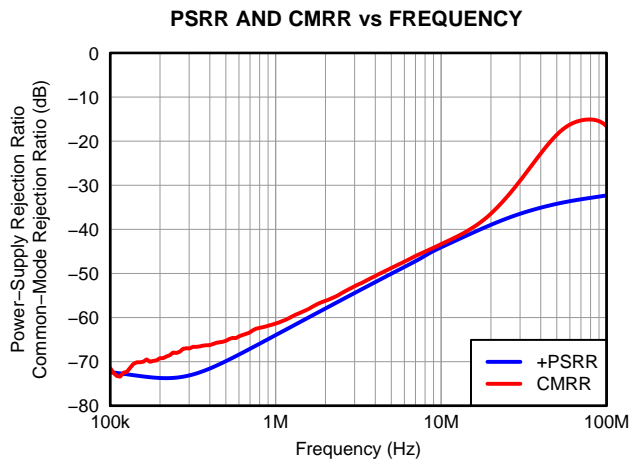

Figure 16.

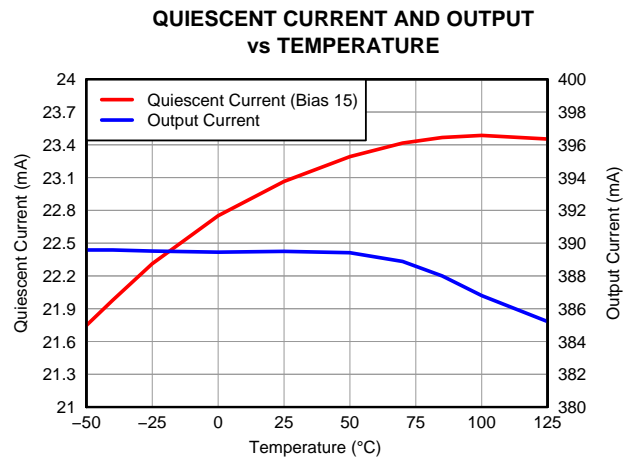

Figure 17.

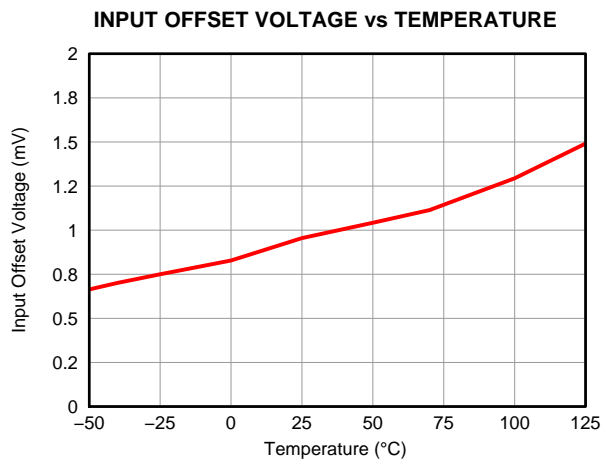

Figure 18.

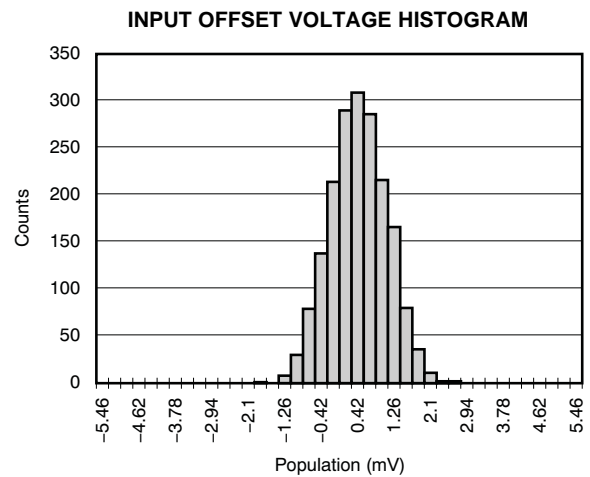

Figure 19.

APPLICATION INFORMATION

The THS6226 class H line driver provides exceptional ac performance in conjunction with wide output voltage swing. The class H operation allows voltage swings to exceed the power supply for short intervals limited only by the charge in the capacitor. In class AB mode, the THS6226 is capable of driving a 60Ω load from +1.9V to +10.1V. In class H mode, under the same conditions, the output voltage range becomes an impressive –5.5V to +17.5V, or 46V_{PP} differentially with the capacitor fully charged.

Figure 20 shows a fully-differential, noninverting amplifier configuration with active impedance. In this configuration, the 10.2Ω matching resistance appears through the transformer as 100Ω, minimizing reflection on the line, while also minimizing transmission losses. The THS6226 gain is fixed and equal to 19V/V from input of the amplifier to the output of the amplifier (IN_{CD} to OUT_{CD}), not including the transformer-turn ratio.

To simplify the implementation as well as provide design flexibility, the THS6226 contains an integrated mid-supply buffer that provides the correct biasing to the amplifier core without requiring any external components. Also present is a two-pin serial interface that provides exceptional design flexibility and allows minimal power consumption for each xDSL profile.

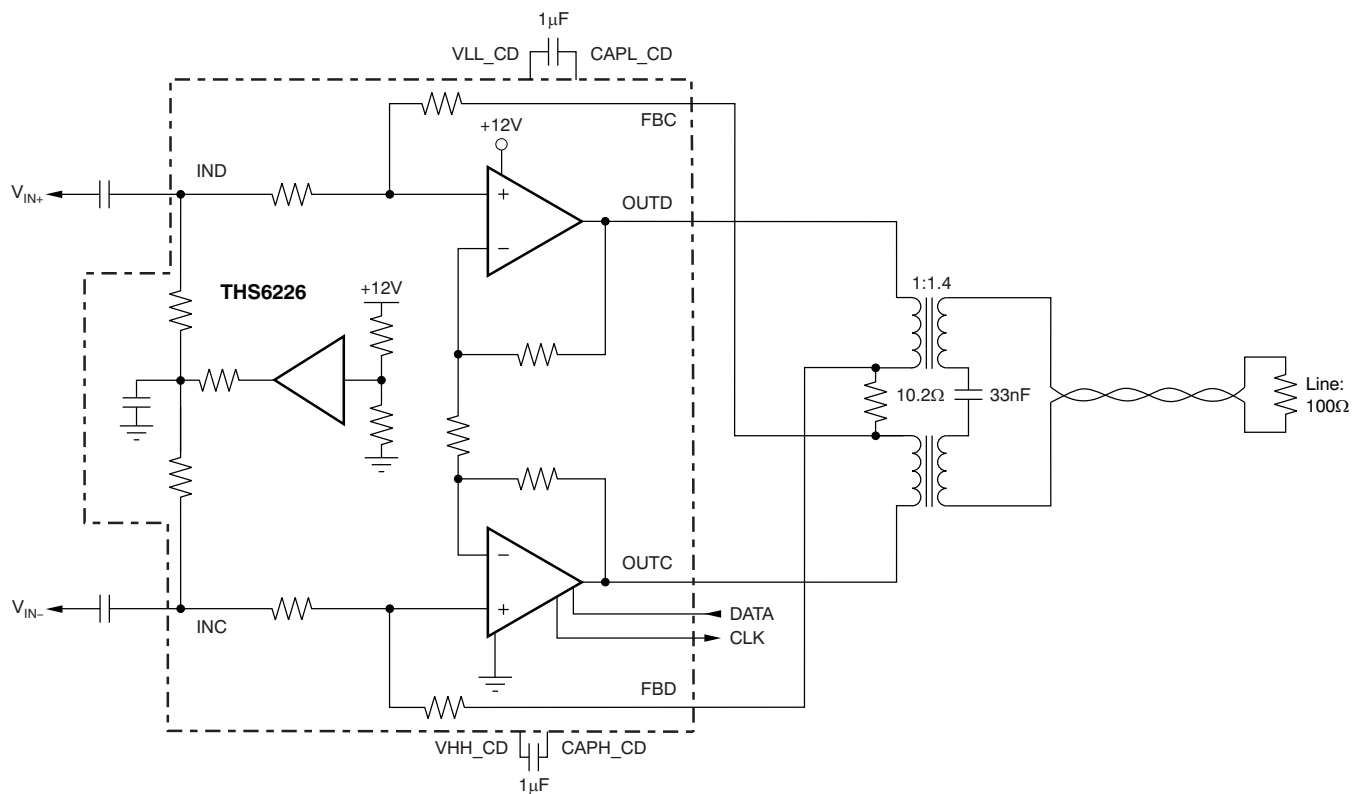

Figure 20. Multi-Tone Power Ratio (MTPR) Test Circuit

PROGRAMMING THE THS6226

Programming of the THS6226 is realized through a serial interface (pins 4 and 5) and proceeds in the following sequence.

Two start bits are required B0 = 0 followed by B1 = 1.

B2 through B9 are used to program the THS6226.

Refer to [Table 1](#) for the bit descriptions.

B10 (refer to [Table 2](#)) is the parity bit that controls if the word is or is not loaded.

B11 is the stop bit and should be set to B11 = 1. [Figure 21](#) shows the sequence to be adopted.

Table 1. SDATA

PARAMETER	DESCRIPTION
B0, B1	Start bit
B2, B3	Channel select
B4, B5	Power-down features
B6-B9	Quiescent current setting
B10	Parity bit
B11	Stop bit

Table 2. Parity Bit

B10	ODD PARITY BIT
0	If odd, number of high bits in B2 to B9
1	If even, number of high bits in B2 to B9

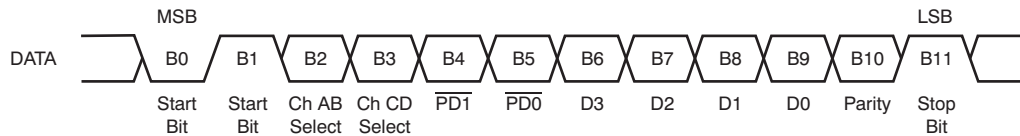

Figure 21. DATA Description

QUIESCENT CURRENT

The quiescent current of the THS6226 is dissipated in two main modules of the THS6226: the class AB and the charge pump. B4 and B5 select the mode of operation, class AB operating with or without the charge pump enabled, powering down the entire port, or operating in a line termination mode. [Table 4](#) lists the details on each bit functionality and the approximate quiescent current.

The class AB quiescent current is set by bits B6 to B9, using B4 and B5 for the power-down function, and B2 and B3 for channel select. The approximate quiescent current for the amplifier core is shown in [Table 3](#).

Table 3. Class AB Quiescent Current

B6 (D3)	B7 (D2)	B8 (D1)	B9 (D0)	QUIESCENT CURRENT SETTING	APPROXIMATE I_Q (mA/Port)
0	0	0	0	ADSL2+ mode	7.6
0	0	0	1		8.7
0	0	1	0	Profile 8b mode	9.8
0	0	1	1		10.9
0	1	0	0	Profile 17a mode	12
0	1	0	1		13
0	1	1	0		14
0	1	1	1		15
1	0	0	0		16
1	0	0	1		17
1	0	1	0	Profile 30a mode	18
1	0	1	1		19
1	1	0	0		20
1	1	0	1		21
1	1	1	0		22
1	1	1	1		23

The various power modes are shown in [Table 4](#). For all modes, when B6 through B9 are not defined, set B9 = B8 = B7 = B6 = 0 to achieve the lowest power dissipation possible.

Table 4. Power Modes

B4 (PD1)	B5 (PD0)	POWER-DOWN MODE	APPROXIMATE I_Q (mA/Port)
0	0	Power-down (B9, B8, B7, B6 = 0)	0.85
0	1	Line termination mode (B9, B8, B7, B6 = 0)	4.4
1	0	Class AB driver I_Q set by B6 to B9, class H disabled	—
1	1	Class AB driver I_Q set by B6 to B9, class H enabled	—

Channel selection is shown in [Table 5](#). Each channel can be programmed independently, or together if both B2 and B3 are set to '1'.

Table 5. Channel Selection

B2 (Channel AB)	B3 (Channel CD)	CHANNEL SELECT
0	0	Bits B4 to B9 are ignored
0	1	Channel B programmed with B4 to B9
1	0	Channel A programmed with B4 to B9
1	1	Channels A and B programmed with B4 to B9

At startup, the internal register is set as shown in [Table 6](#).

Table 6. Internal Register

B2 (Channel AB)	B3 (Channel CD)	B4 (PD1)	B5 (PD0)	B6 (D3)	B7 (D2)	B8 (D1)	B9 (D0)
0	0	0	0	0	0	0	0



In this condition, the total quiescent power dissipation is 10.2mW/port on a +12V supply.

REVISION HISTORY

NOTE: Page numbers for previous revisions may differ from page numbers in the current version.

Changes from Revision B (February 2011) to Revision C	Page
• Changed LOGIC, <i>Logic pin input impedance</i> typical specification and unit in Electrical Characteristics table	4
• Changed Timing Characteristics section	6

PACKAGING INFORMATION

Orderable Device	Status (1)	Package Type	Package Drawing	Pins	Package Qty	Eco Plan (2)	Lead finish/ Ball material (6)	MSL Peak Temp (3)	Op Temp (°C)	Device Marking (4/5)	Samples
THS6226IRHBR	ACTIVE	VQFN	RHB	32	3000	RoHS & Green	NIPDAU	Level-3-260C-168 HR	-40 to 85	THS6226 IRHB	
THS6226IRHBT	ACTIVE	VQFN	RHB	32	250	RoHS & Green	NIPDAU	Level-3-260C-168 HR	-40 to 85	THS6226 IRHB	

(1) The marketing status values are defined as follows:

ACTIVE: Product device recommended for new designs.

LIFEBUY: TI has announced that the device will be discontinued, and a lifetime-buy period is in effect.

NRND: Not recommended for new designs. Device is in production to support existing customers, but TI does not recommend using this part in a new design.

PREVIEW: Device has been announced but is not in production. Samples may or may not be available.

OBSOLETE: TI has discontinued the production of the device.

(2) **RoHS:** TI defines "RoHS" to mean semiconductor products that are compliant with the current EU RoHS requirements for all 10 RoHS substances, including the requirement that RoHS substance do not exceed 0.1% by weight in homogeneous materials. Where designed to be soldered at high temperatures, "RoHS" products are suitable for use in specified lead-free processes. TI may reference these types of products as "Pb-Free".

RoHS Exempt: TI defines "RoHS Exempt" to mean products that contain lead but are compliant with EU RoHS pursuant to a specific EU RoHS exemption.

Green: TI defines "Green" to mean the content of Chlorine (Cl) and Bromine (Br) based flame retardants meet JS709B low halogen requirements of <=1000ppm threshold. Antimony trioxide based flame retardants must also meet the <=1000ppm threshold requirement.

(3) MSL, Peak Temp. - The Moisture Sensitivity Level rating according to the JEDEC industry standard classifications, and peak solder temperature.

(4) There may be additional marking, which relates to the logo, the lot trace code information, or the environmental category on the device.

(5) Multiple Device Markings will be inside parentheses. Only one Device Marking contained in parentheses and separated by a "~" will appear on a device. If a line is indented then it is a continuation of the previous line and the two combined represent the entire Device Marking for that device.

(6) Lead finish/Ball material - Orderable Devices may have multiple material finish options. Finish options are separated by a vertical ruled line. Lead finish/Ball material values may wrap to two lines if the finish value exceeds the maximum column width.

Important Information and Disclaimer:The information provided on this page represents TI's knowledge and belief as of the date that it is provided. TI bases its knowledge and belief on information provided by third parties, and makes no representation or warranty as to the accuracy of such information. Efforts are underway to better integrate information from third parties. TI has taken and continues to take reasonable steps to provide representative and accurate information but may not have conducted destructive testing or chemical analysis on incoming materials and chemicals. TI and TI suppliers consider certain information to be proprietary, and thus CAS numbers and other limited information may not be available for release.

In no event shall TI's liability arising out of such information exceed the total purchase price of the TI part(s) at issue in this document sold by TI to Customer on an annual basis.

TAPE AND REEL INFORMATION

QUADRANT ASSIGNMENTS FOR PIN 1 ORIENTATION IN TAPE

*All dimensions are nominal

Device	Package Type	Package Drawing	Pins	SPQ	Reel Diameter (mm)	Reel Width W1 (mm)	A0 (mm)	B0 (mm)	K0 (mm)	P1 (mm)	W (mm)	Pin1 Quadrant
THS6226IRHBR	VQFN	RHB	32	3000	330.0	12.4	5.3	5.3	1.1	8.0	12.0	Q2
THS6226IRHBT	VQFN	RHB	32	250	180.0	12.4	5.3	5.3	1.1	8.0	12.0	Q2

TAPE AND REEL BOX DIMENSIONS

*All dimensions are nominal

Device	Package Type	Package Drawing	Pins	SPQ	Length (mm)	Width (mm)	Height (mm)
THS6226IRHBR	VQFN	RHB	32	3000	346.0	346.0	33.0
THS6226IRHBT	VQFN	RHB	32	250	210.0	185.0	35.0

GENERIC PACKAGE VIEW

RHB 32

VQFN - 1 mm max height

5 x 5, 0.5 mm pitch

PLASTIC QUAD FLATPACK - NO LEAD

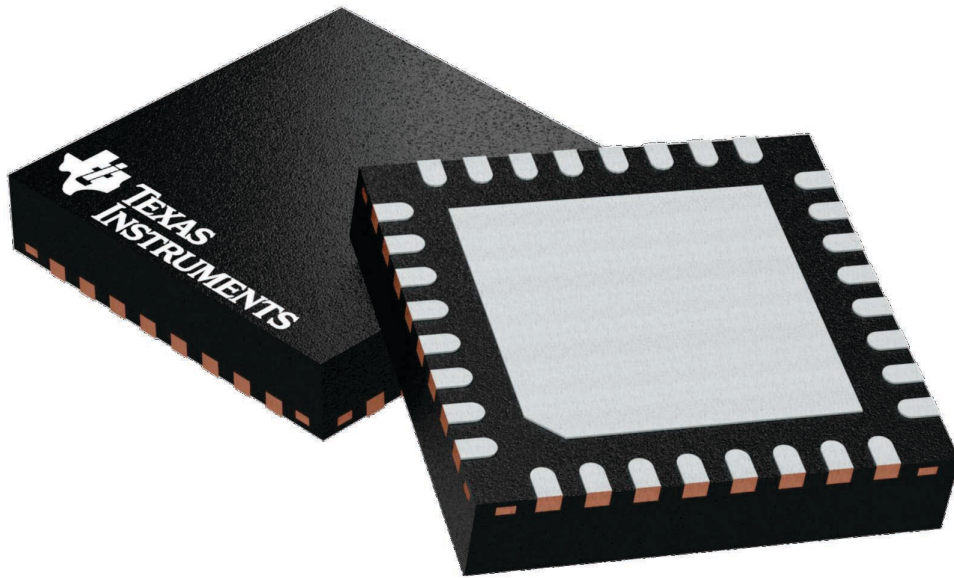

Images above are just a representation of the package family, actual package may vary.
Refer to the product data sheet for package details.

4224745/A

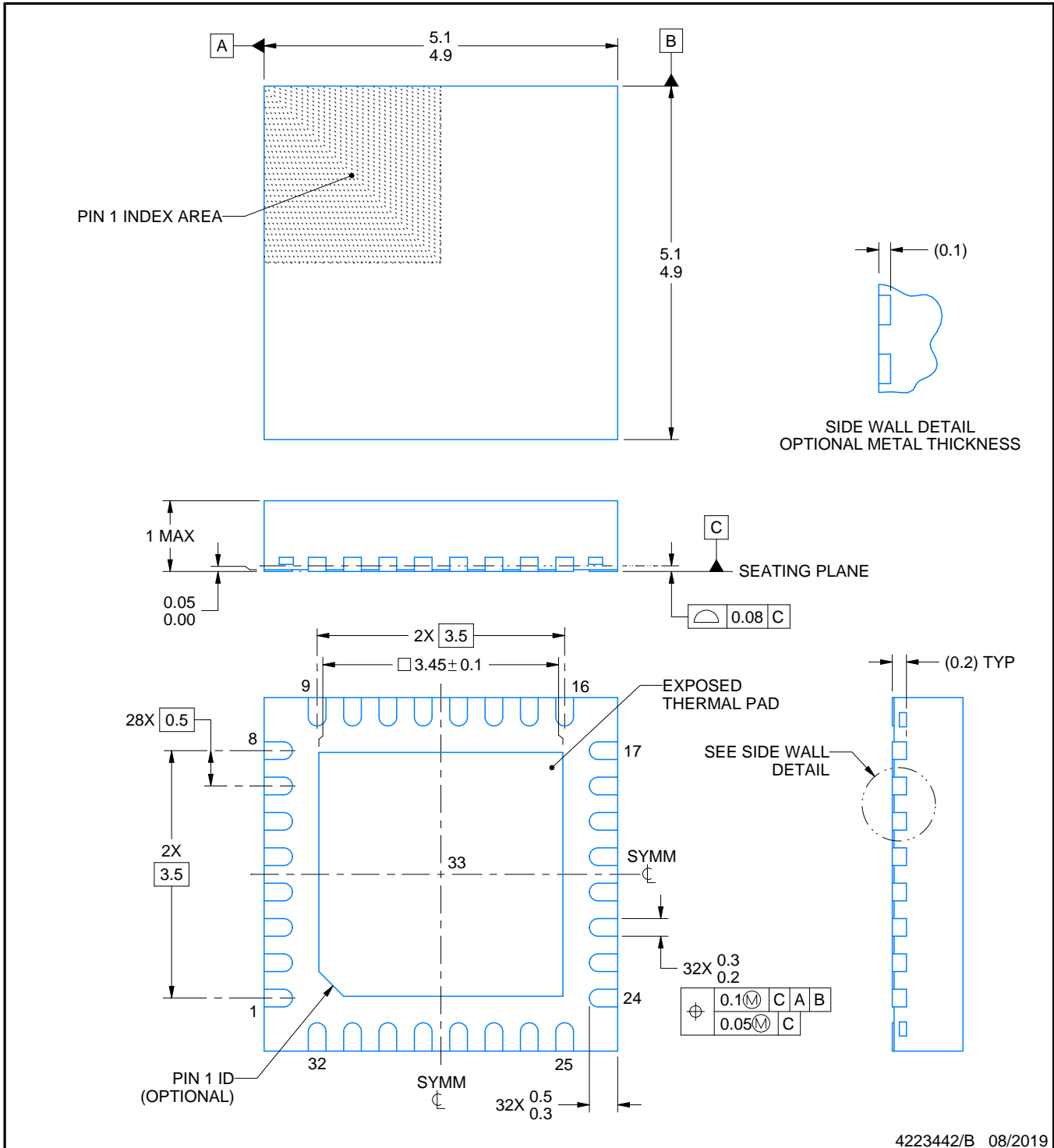
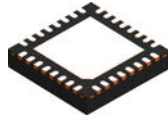

NOTES:

1. All linear dimensions are in millimeters. Any dimensions in parenthesis are for reference only. Dimensioning and tolerancing per ASME Y14.5M.
2. This drawing is subject to change without notice.
3. The package thermal pad must be soldered to the printed circuit board for thermal and mechanical performance.

EXAMPLE BOARD LAYOUT

RHB0032E

VQFN - 1 mm max height

PLASTIC QUAD FLATPACK - NO LEAD

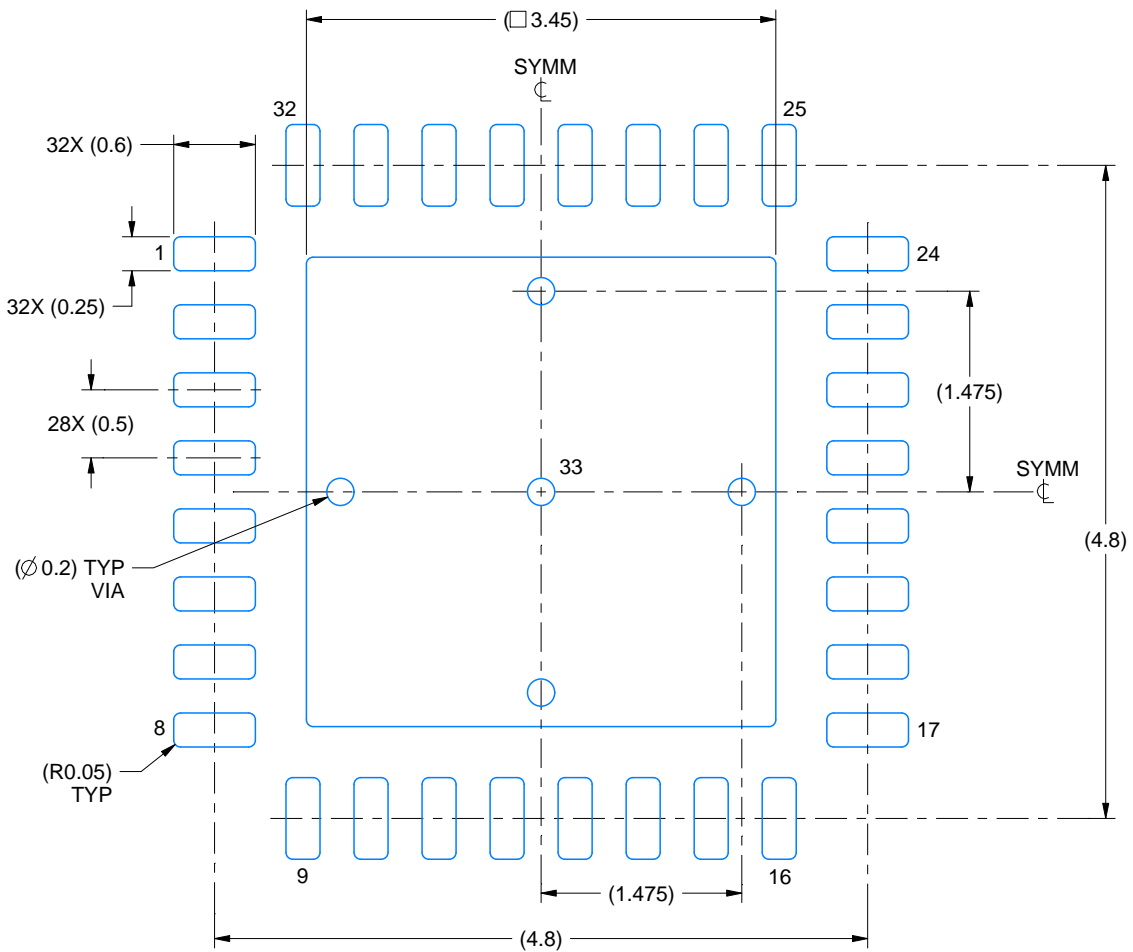

LAND PATTERN EXAMPLE
SCALE:18X

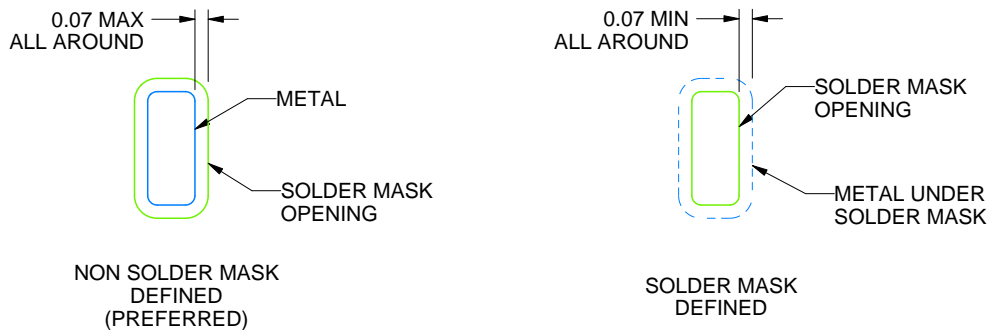

SOLDER MASK DETAILS

4223442/B 08/2019

NOTES: (continued)

4. This package is designed to be soldered to a thermal pad on the board. For more information, see Texas Instruments literature number SLUA271 (www.ti.com/lit/slua271).
5. Vias are optional depending on application, refer to device data sheet. If any vias are implemented, refer to their locations shown on this view. It is recommended that vias under paste be filled, plugged or tented.

EXAMPLE STENCIL DESIGN

RHB0032E

VQFN - 1 mm max height

PLASTIC QUAD FLATPACK - NO LEAD

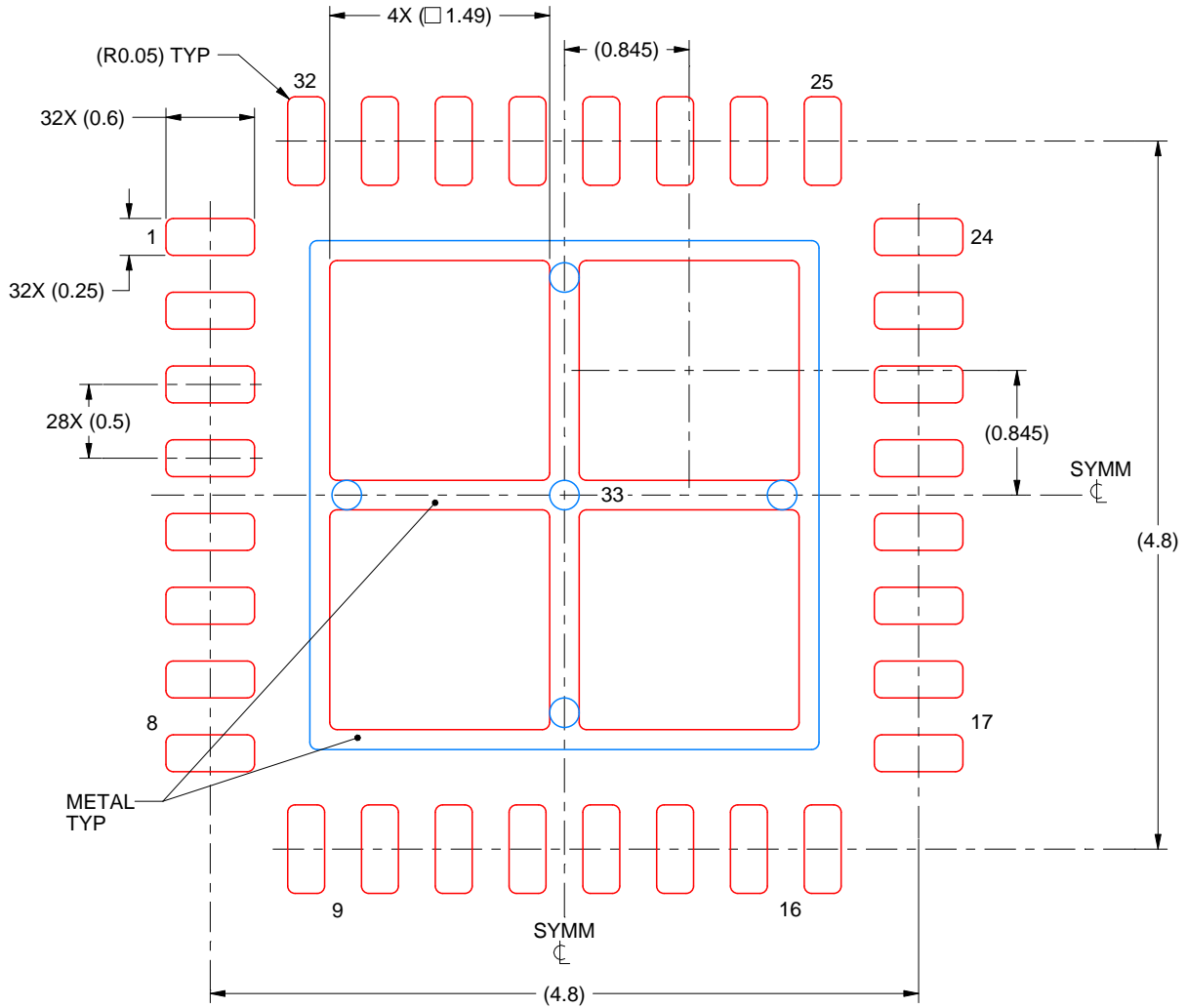

SOLDER PASTE EXAMPLE
 BASED ON 0.125 mm THICK STENCIL

EXPOSED PAD 33:
 75% PRINTED SOLDER COVERAGE BY AREA UNDER PACKAGE
 SCALE:20X

4223442/B 08/2019

NOTES: (continued)

6. Laser cutting apertures with trapezoidal walls and rounded corners may offer better paste release. IPC-7525 may have alternate design recommendations.

IMPORTANT NOTICE AND DISCLAIMER

TI PROVIDES TECHNICAL AND RELIABILITY DATA (INCLUDING DATA SHEETS), DESIGN RESOURCES (INCLUDING REFERENCE DESIGNS), APPLICATION OR OTHER DESIGN ADVICE, WEB TOOLS, SAFETY INFORMATION, AND OTHER RESOURCES "AS IS" AND WITH ALL FAULTS, AND DISCLAIMS ALL WARRANTIES, EXPRESS AND IMPLIED, INCLUDING WITHOUT LIMITATION ANY IMPLIED WARRANTIES OF MERCHANTABILITY, FITNESS FOR A PARTICULAR PURPOSE OR NON-INFRINGEMENT OF THIRD PARTY INTELLECTUAL PROPERTY RIGHTS.

These resources are intended for skilled developers designing with TI products. You are solely responsible for (1) selecting the appropriate TI products for your application, (2) designing, validating and testing your application, and (3) ensuring your application meets applicable standards, and any other safety, security, regulatory or other requirements.

These resources are subject to change without notice. TI grants you permission to use these resources only for development of an application that uses the TI products described in the resource. Other reproduction and display of these resources is prohibited. No license is granted to any other TI intellectual property right or to any third party intellectual property right. TI disclaims responsibility for, and you will fully indemnify TI and its representatives against, any claims, damages, costs, losses, and liabilities arising out of your use of these resources.

TI's products are provided subject to [TI's Terms of Sale](#) or other applicable terms available either on [ti.com](https://www.ti.com) or provided in conjunction with such TI products. TI's provision of these resources does not expand or otherwise alter TI's applicable warranties or warranty disclaimers for TI products.

TI objects to and rejects any additional or different terms you may have proposed.

Mailing Address: Texas Instruments, Post Office Box 655303, Dallas, Texas 75265
Copyright © 2023, Texas Instruments Incorporated