

Name of product RF FRONT-END SYSTEM UNIT

品名 R F フロントエンドシステムユニット

Part No.

品番 E N G 3 6 A 0 4 G

Used type

ご使用機種

Specification (For supply)

TENTATIVE

納入仕様書

Reception used column

受領印



MATSUSHITA ELECTRONIC COMPONENTS CO.,LTD.

松下電子部品株式会社

MODULE DEVICE COMPANY

モジュールデバイスカンパニー

MODULE BUSINESS UNIT

モジュールビジネスユニット

チューナグローバル事業センター グローバル技術チーム

992-1 AIBA OHNO-CHO IBI-GUN GIFU,501-0597 JAPAN

〒501-0597 岐阜県揖斐郡大野町大字相羽992-1

TEL. (0585) 32 - 4104

FAX. (0585) 36 - 2353

Manufacturing
section
製造部署

TCOM(THAILAND)

The materials of this product are designated as the existing chemical materials based on the law on the regulations of inspection, production and others of chemical materials.

この製品の使用材料は、「化学物質の審査及び製造等の規制に関する法律」に基き、すべて既存科学物質として記載されている材料です。

納入仕様書類 改訂履歴書

PRODUCTS NAME RF FRONT-END SYSTEM UNIT PRODUCTS No. ENG36A04G
 製品名 RFフロントエンドシステムユニット 品番
 CUSTOMER USE 御使用機種 ()

No	Issue No and Date 発行 No 発行日	Amendments division 変更区分	page 改訂頁	point 改訂箇所	The details of a Revision and Reason 改訂内容 & 理由	Enforcement date 実施予定日 実施日	Reception date 受領日
1	DM-03-021 10.OCT.'03	NEW	—	—	Newly 新規導入		

Note:
備考

ISSUED BY	MATSUSHITA ELECTRONIC COMPONENTS CO.,LTD. MODULE DEVICE COMPANY MODULE BUSINESS UNIT	CHECK SATO	CHECK FUJITA	DESIGN OKUDA AKATSUKA
-----------	--	---------------	-----------------	-----------------------------

CLASSIFICATION 標準書名	PRODUCTS SPECIFICATION (FOR SUPPLY) 納入仕様書	No.	151-ENG-0813
SUBJECT 品名 RF FRONT-END SYSTEM UNIT RFフロントエンドシステムユニット		PAGE	1 OF 14
		DATE 日付	28.MAR.2003

ENG36A04G

1 SCOPE

適用範囲

1.1 Applicable Tuner

機種

This specification applies to RF FRONT-END SYSTEM UNIT ENG36A04G
この仕様書はRFフロントエンドシステムユニットに適用する。

1.2 Type

方式

1.2.1 Channel:

チャンネル

USA (include CATV ch)

Standard
標準

Band I	ch. 2 ~ B
Band II	ch. C ~ KK
Band III	ch. ~
Band	ch. LL ~ 69

1.2.2 Receiving System: NTSC

受信方式

1.2.3 Intermediate Frequency:

中間周波数

VIF	<u>45.75 MHz</u>
CIF	<u>42.17 MHz</u>
SIF	<u>41.25 MHz</u>

1.2.4 Input / Output system:

入出力方式

RF IN	<u>75 Unbalance</u>	<u>Pin Jack</u>
	不平衡	P.J

Baseband ベースバンド	TYP. 1.0 V(p-p)	VIDEO OUT Terminal 映像出力端子
	TYP. 95dB(μV)	SIF OUT Terminal SIF端子
	TYP. 0.5 V(rms)	AUDIO OUT Terminal AUDIO出力端子

1.2.5 BAND Change-over system : Digital change by PLL IC

BAND 切替方式 PLL ICによるデジタル切替

1.2.6 Prescaler : Pulse swallow PLL system

プリスケラ PLLパルススワロー方式

2 APPLICABLE STANDARD

適合規格

The product conforms: UL/NEW FCC, CSA/BETS-7

この製品はUL/NEW FCC, CSA/BETS-7適合する。

MATSUSHITA ELECTRONIC COMPONENTS CO., LTD.. MODULE DEVICE COMPANY.	CHECK SATO	CHECK FUJITA	DESIGN OKUDA AKATSUKA
---	---------------	-----------------	-----------------------------

CLASSIFICATION 標準書名	PRODUCTS SPECIFICATION (FOR SUPPLY) 納入仕様書	No.	151-ENG-0813
SUBJECT 品名 RF FRONT-END SYSTEM UNIT RFフロントエンドシステムユニット		PAGE	2 OF 14
		DATE 日付	28.MAR.2003

ENG36A04G

3 RATINGS AND TEST CONDITIONS

定格及び試験条件

Measurements shall be made under room temperature and humidity conditions.

The following conditions shall be applied for the measurement of electrical characteristics unless otherwise specified.

測定は常温常湿とし、電気特性は特に指定する以外は下記の条件にて行う。

3.1 Voltage & current at each terminal and operation guaranteed voltage.

各端子の電圧、電流及び動作保証電圧

Terminal 端子	Supply Voltage 印加電圧 (V)	Current 電流 AGC G. MAX (mA)		Operation Voltage range 使用電圧範囲 (V)
		TYP	MAX	
+B	5.0	190	250	5.0 ± 0.1

3.2 Maximum allowable voltage

最大許容電圧

+B : Terminals, the conditions must be the hatched area.

+B端子については、上図斜線で示す領域以外の条件は瞬時といえども与えてはならない。

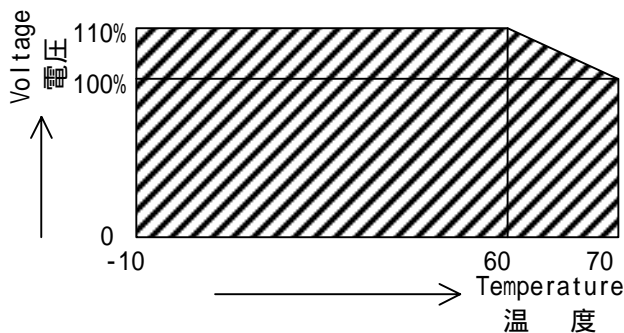

3.3 Operation guaranty - 10 ~ +70

動作保証温度

3.4 Operation temperature range 0 ~ +60

使用温度範囲

3.5 Signal levels are 75 closed unless other condition is specified.

レベル校正 特に指定のない限り 75 終端値

MATSUSHITA ELECTRONIC COMPONENTS CO., LTD..
MODULE DEVICE COMPANY.

CLASSIFICATION 標準書名	PRODUCTS SPECIFICATION (FOR SUPPLY) 納入仕様書	No.	151-ENG-0813
SUBJECT 品名 RF FRONT-END SYSTEM UNIT RFフロントエンドシステムユニット ENG36A04G		PAGE	3 OF 14
		DATE 日付	28.MAR.2003

4 Performance of Tuner section

チューナ部性能

4.1 Specified channels (The specified channels shall be as follows unless particularly specified.)

指定チャンネル (特に指定のない限り次の通りとする)

VHF: ch. 2, 6, A-2, B, C, I, 10, J, N, R, W, FF, KK

UHF: ch. LL, QQ, WW, 14, 20, 26, 32, 38, 44, 50, 56, 62, 69

4.2 High-frequency wave characteristics

高周波特性

Test Items 試験項目	Test Conditions 試験条件	Specifications 規格
1. NF	Gain Max.	ch. 2 ~ 6 : MAX. 8.0 dB : TYP. 6.0 dB ch. A-5 ~ I : MAX. 9.5 dB : TYP. 6.5 dB ch. 7 ~ W : MAX. 8.0 dB : TYP. 5.5 dB ch. AA ~ FFF : MAX. 9.5 dB : TYP. 6.5 dB ch. 14 ~ 69 : MAX. 9.5 dB : TYP. 7.0 dB
2. Effective Gain Control Range 有効利得制御範囲	V/U Reverse AGC Not include rebound. 但し、ハネ返りは含まない。	Ch. 2 ~ B : MIN. 40 dB ch. C ~ KK : MIN. 35 dB ch. LL ~ 69 : MIN. 30 dB

MATSUSHITA ELECTRONIC COMPONENTS CO., LTD..
MODULE DEVICE COMPANY.

CLASSIFICATION 標準書名	PRODUCTS SPECIFICATION (FOR SUPPLY) 納入仕様書	No.	151-ENG-0813
SUBJECT 品名 RF FRONT-END SYSTEM UNIT RFフロントエンドシステムユニット		PAGE	4 OF 14
		DATE 日付	28.MAR.2003

ENG36A04G

4.3 REJECTION CHARACTERISTICS
妨害特性

Test Items 試験項目	Test Conditions 試験条件	Specifications 規格		
1. Image Rejection イメージ妨害比	G.MAX Regulated by -D/u + S/i -D/u + S/iで規定	Channel	GAIN MAX MIN. (dB)	
		2 ~ B	60.0	
		C ~ 13	60.0	
		J ~ FFF	50.0	
		LL ~ 69	45.0	
2. IF Rejection IF妨害比	G.MAX Regulated by -D/u + S/i -D/u + S/iで規定	Channel	GAIN MAX MIN. (dB)	
		2	50.0	
		3	60.0	
		4 ~ 6	70.0	
		A-5 ~ B	70.0	
		C ~ FFF	70.0	
3. 1% Cross Modulation 1% 混変調率 (Next to the adjacent) (隣々接) ± 12MHz (adjacent) (隣接) ± 6MHz	75 OPEN	Channel チャンネル	Worst point 最悪点 MIN. (dB μ)	-30dB point -30dB 点 MIN. (dB μ)
		2 ~ KK	75.0	85.0
		LL ~ FFF	70.0	85.0
		16	65.0	85.0
		67	65.0	85.0
		Channel チャンネル	Worst point 最悪点 MIN. (dB μ)	-30dB point -30dB 点 MIN. (dB μ)
		9 10	62.0	82.0
4. 1/2 IF Rejection 1/2 IF 妨害比	AGC G.R 20dB D/u=0dB Input 入力 80dB μ Provide S/I at tuner IF output. 出力 S/I で規定	ch. 14 ~ 69 : MIN. 50 dB		

MATSUSHITA ELECTRONIC COMPONENTS CO., LTD..
MODULE DEVICE COMPANY .

CLASSIFICATION 標準書名	PRODUCTS SPECIFICATION (FOR SUPPLY) 納入仕様書	No.	151-ENG-0813
SUBJECT 品名 RF FRONT-END SYSTEM UNIT RFフロントエンドシステムユニット		PAGE	5 OF 14
		DATE 日付	28.MAR.2003

ENG36A04G

4.4 Local oscillation characteristics
局部発振特性

Test Items 試験項目	Test Conditions 試験条件	Specifications 規格			
1. Tuning voltage 同調電圧 Please be tentative for pulse swallow PLL system. PLL選局のため参考値		Channel	MIN. (V)	TYP. (V)	MAX. (V)
		2		1.0	
		6		5.6	
		A-2		11.0	
		B		19.0	
		C		1.1	
		I		3.7	
		10		5.3	
		J		6.8	
		N		8.4	
		R		10.2	
		W		13.0	
		FF		17.8	
		KK		24.0	
		LL		1.1	
		QQ		1.8	
		WW		3.2	
		14		4.8	
		20		6.6	
		26		8.0	
32		9.8			
38		11.0			
44		13.1			
50		14.9			
56		17.0			
62		20.0			
69		24.0			
2. Local oscillation starting voltage 局部発振開始電圧	+B variable +B可変	ch. 2 ~ KK : MAX. 4.6 V			
		ch. LL ~ 69 : MAX. 4.6 V			
3. B Voltage drift B電圧ドリフト (TENTATIVE) (参考)	+B ± 10% PLL Function チューナ部のみ規定	ch. 2 ~ B : MAX. ± 30 kHz			
		ch. C ~ KK : MAX. ± 30 kHz			
		ch. LL ~ 69 : MAX. ± 30 kHz			

MATSUSHITA ELECTRONIC COMPONENTS CO., LTD..
MODULE DEVICE COMPANY.

CLASSIFICATION 標準書名	PRODUCTS SPECIFICATION (FOR SUPPLY) 納入仕様書	No.	151-ENG-0813
SUBJECT 品名		PAGE	6 OF 14
		DATE 日付	28.MAR.2003
		ENG36A04G	

Test Items 試験項目	Test Conditions 試験条件	Specifications 規格							
4. Warm-up drift ウォームアップドリフト (TENTATIVE) (参考)	PLL Function チューナ部のみ規定	Condition 条件	Channel チャンネル	+ (kHz)	- (kHz)				
						-10 + 25 up	2~B	MAX. 60.0	MAX. 60.0
							C~KK	MAX. 60.0	MAX. 60.0
		LL~69	MAX. 60.0	MAX. 60.0					
		15 + 25 up	2~B	MAX. 60.0	MAX. 60.0				
			C~KK	MAX. 60.0	MAX. 60.0				
			LL~69	MAX. 60.0	MAX. 60.0				
		40 + 25 up	2~B	MAX. 60.0	MAX. 60.0				
			C~KK	MAX. 60.0	MAX. 60.0				
			LL~69	MAX. 60.0	MAX. 60.0				

MATSUSHITA ELECTRONIC COMPONENTS CO., LTD.. MODULE DEVICE COMPANY.	
---	--

CLASSIFICATION 標準書名	PRODUCTS SPECIFICATION (FOR SUPPLY) 納入仕様書	No.	151-ENG-0813
SUBJECT 品名	RF FRONT-END SYSTEM UNIT RFフロントエンドシステムユニット	PAGE	7 OF 14
	ENG36A04G	DATE 日付	28.MAR.2003

5 PLL Part Characteristics

PLL部特性

5.1 Band switching output

バンド切替出力

BAND		Band switching output data バンド切替出力データ							
		X	X	X	X	B4	B3	B2	B1
BAND	ch. 2 ~ B	--	--	--	--	0	--	0	1
BAND	ch. C ~ KK	--	--	--	--	0	--	1	0
BAND IV	ch. LL ~ 69	--	--	--	--	1	--	0	0

(Notes) There are no abnormal operations when input data are 1 or 0 to I/O port 'X'.

(注意) I/O port 'X' に1又は0のデータが入力されても異常な動作が無いこと。

5.2 Bit forward

ビット転送

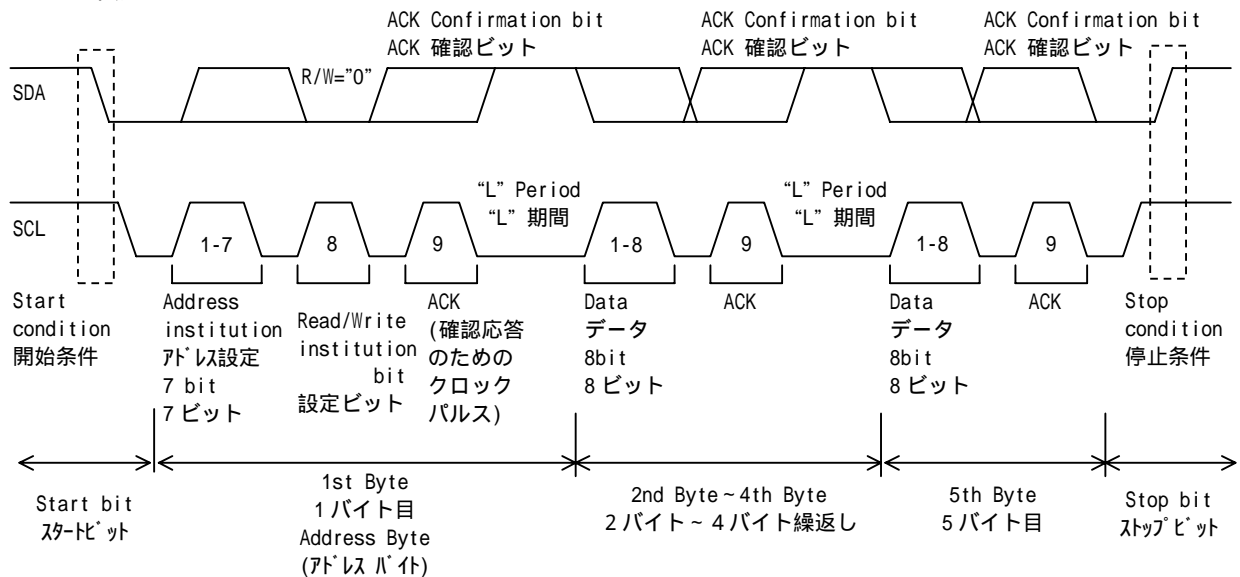

5.3 Tuning Frequency

同調周波数

$$f_{v.c.o} = f_{step} \times n \quad [\text{kHz}]$$

$$\left(\begin{array}{l} n_{14} \text{ to } n_0 \text{ are the programable divider bits:} \\ n = n_{14} \times 2^{14} + n_{13} \times 2^{13} + \dots + n_1 \times 2 + n_0 \end{array} \right)$$

Reference divider	fstep
640	50.00
1024	31.25
512	62.50

CLASSIFICATION 標準書名	PRODUCTS SPECIFICATION (FOR SUPPLY) 納入仕様書	No.	151-ENG-0813
SUBJECT 品名 RF FRONT-END SYSTEM UNIT RFフロントエンドシステムユニット		PAGE	8 OF 14
		DATE 日付	28.MAR.2003

ENG36A04G

5.4 Input Signal Voltage(Tuner Section)

入力信号レベル (チュ - ナ部)
(SDA, SCL)

“ L ” Input Voltage Max. 1.2 V
入力 電圧

“ H ” Input Voltage Min. 3.5 V Max. 5.5 V
入力 電圧

Write data format

	MSB							LSB			
address	1	1	0	0	0	0	0	0*	A	byte 1	
programable divider	0	n14	n13	n12	n11	n10	n9	n8	A	byte 2	
programable divider	n7	n6	n5	n4	n3	n2	n1	n0	A	byte 3	
charge-pump and test bits	1	CP	0	0	1	RSA	RSB	0	A	byte 4	
I/O port control bits	X	X	X	X	B4	B3	B2	B1	A	byte 5	

Ratio select bits
分周比設定ビット

RSA	RSB	Reference divider
X	0	640
0	1	1024
1	1	512

Where
X is don't care.

A is the acknowledge bit.
O' = Read/Write institution bit is "0".
n14 to n0 are the programmable divider bits :
 $n = n14 \times 2^{14} + n13 \times 2^{13} + \dots + n1 \times 2 + n0$.
CP is don't care.
B4 to B1 = 1 : limited current output is active.
B4 to B1 = 0 : output are in high - impedance state.

5.5 Frequency Stability

周波数確度

MAX . ± 60 kHz

at Ch69 tuning
Ch69 選局時

5.6 Lock up speed

ロックアップスピード

MAX . 250 msec

at ch2 ch69 tuning +B : 5V
ch2 ch69

5.7 Clock Noise

クロックノイズ

There shall be no trouble when mounted.
セット実装にて実用上問題のないこと。

5.8 Read data format

	MSB							LSB		
Address byte	1	1	0	0	0	0	0	1	A	
Status byte	POR	FL	R	1	1	A2	A1	A0	A	

Digital AFC status

A2	A1	A0	Frequency
0	0	0	-90
0	0	1	-35
0	1	0	0
0	1	1	+35
1	0	0	+90

[kHz]

POR : Power-on reset flag
logic 0:after an end-of-data detected by the device
logic 1:at power-on
FL : in-lock flag
logic 0:loop is not locked
logic 1:loop is locked
R :ready flag
logic 0:mode after Power-on reset and the PLL is locked
logic 1:in other condition
A2,A1 and A0:digital output of the 5-level ADC

MATSUSHITA ELECTRONIC COMPONENTS CO., LTD..
MODULE DEVICE COMPANY.

CLASSIFICATION 標準書名	PRODUCTS SPECIFICATION (FOR SUPPLY) 納入仕様書	No.	151-ENG-0813
SUBJECT 品名	RF FRONT-END SYSTEM UNIT RFフロントエンドシステムユニット	PAGE	9 OF 14
	ENG36A04G	DATE 日付	28.MAR.2003

5.9 BUS TIMING

I2Cバスのデータタイミング

www.datasheet4u.com

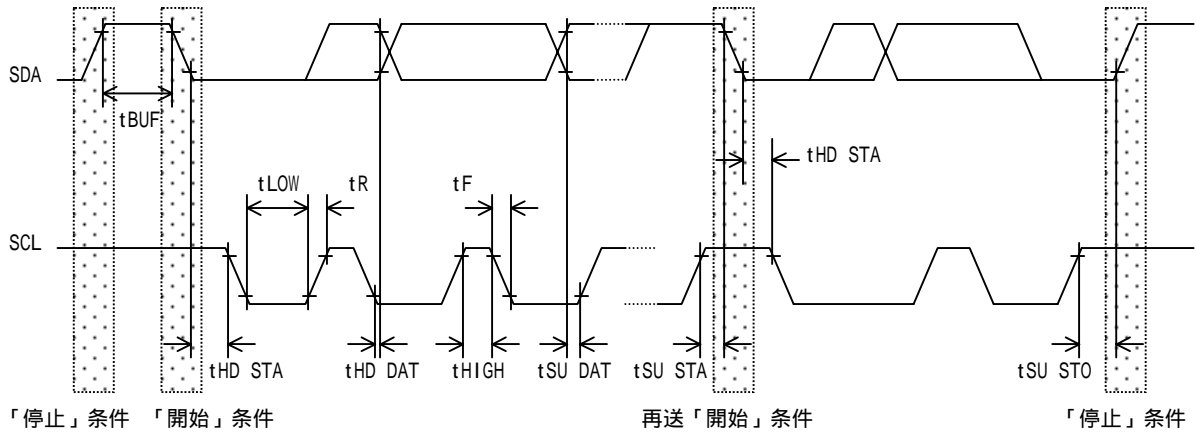

Parameter 項目	Symbol 記号	Min	Max	Unit 単位
SCL clock frequency SCLクロック周波数	f SCL	0	100	kHz
Bus free time between a STOP and START condition. 「停止」条件と「開始」条件の間のバスフリータイム	t BUF	4.7	---	μs
Hold time (repeated) START condition. After this period the first clock pulse is generated. ホールドタイム(再送)「開始」条件。 この期間の後、最初のクロックパルスが生成されます。	t HDSTA	4	---	μs
LOW period of the SCL clock. SCLクロックのLOW状態ホールドタイム	t LOW	4.7	---	μs
HIGH period of the SCL clock. SCLクロックのHIGH状態ホールドタイム	t HIGH	4	---	μs
Set-up time for a repeated START condition. 再送「開始」条件のセットアップ時間	t SUSTA	4.7	---	μs
DATA hold time データ・ホールド・タイム	t HDDAT	0	---	ns
DATA set-up time データ・セットアップ時間	t SUDAT	250	---	ns
Rise time of both SDA and SCL signals. SDA及びSCL信号の立ち上がり時間	t R	---	1000	ns
Fall time of both SDA and SCL signals. SDA及びSCL信号の立ち下がり時間	t F	---	300	ns
Set-up time for STOP condition. 「停止」条件のセットアップ時間	t SUSTO	4	---	μs
Capacitive load for each bus line. 各バスラインの容量性負荷	C b	---	350	pF

MATSUSHITA ELECTRONIC COMPONENTS CO., LTD..
MODULE DEVICE COMPANY.

CLASSIFICATION 標準書名	PRODUCTS SPECIFICATION (FOR SUPPLY) 納入仕様書	No.	151-ENG-0813
SUBJECT 品名 RF FRONT-END SYSTEM UNIT RFフロントエンドシステムユニット		PAGE	10 OF 14
		DATE 日付	28.MAR.2003

ENG36A04G

6 PERFORMANCE OF VIF SECTION
V I F 部性能

Test Items 試験項目	Test Conditions 試験条件	Specifications 規格			
1. Max. signal level at S/N = 30dB 雑音制限感度			MAX. (dB μ)		
		VHF	51.0		
		UHF	52.0		
2. VIDEO S/N 映像S/N	Input : 75 dB μ 入力 Video mod.: 87.5 % 映像変調		Channel	MIN. (dB)	
		VHF	12	40.0	
		UHF	33	40.0	
		Video signal : White ビデオ信号 白 100%			
3. MAX. Input level 最大入力レベル	P/S = 10 dB		MIN. (dB μ)		
		VHF	96.0		
		UHF	96.0		
		Measuring method : There shall be no problem in the practical operation with no color dying and excessive pull out. 測定法 : 色消え、ビ - ト、極端な同期流れを起さなく、実用上問題がないこと。			
4. AGC Characteristics AGC特性	Video signal color bar 標準カラ - バ - 信号 Video mod.: 87.5 % 映像変調	VHF/UHF : Less than 3dB for 36dB μ to 96dB μ input signal level. (Video level) 入力 36 ~ 96dB μ で 3dB以内 (ビデオレベル)			
5. Video frequency Characteristics 映像周波数特性	Input : 75 dB μ 入力 Video mod.: 70 % 映像変調 VHF : ch 12 UHF : ch 33		VHF	UHF	
		0.1 MHz	0 dB	0 dB	
		1.0 MHz	0 \pm 3 dB	0 \pm 3 dB	
		2.0 MHz	0 \pm 3 dB	0 \pm 3 dB	
		3.0 MHz	-0.5 \pm 3 dB	-0.5 \pm 4 dB	
		3.58 MHz	-3 \pm 3 dB	-3 \pm 4 dB	
		4.5 MHz	MIN. -38 dB	MIN. -38 dB	
6. Video output 映像出力	Input : 75 dB μ 入力 Video mod.: 87.5 % 映像変調 Video signal color bar 標準カラ - バ - 信号 + B = 5 \pm 0.1V		Video output 映像出力 (Vp-p)	Horizontal sync 同期信号 (%)	Burst signal バースト信号 MIN. (Vp-p)
		VHF	1.0 \pm 0.20	27.0 \pm 3.0	0.14 ~ 0.36
		UHF	1.0 \pm 0.20	27.0 \pm 3.0	0.14 ~ 0.36
					(1.0Vp-p換算値)

MATSUSHITA ELECTRONIC COMPONENTS CO., LTD..
MODULE DEVICE COMPANY.

CLASSIFICATION 標準書名	PRODUCTS SPECIFICATION (FOR SUPPLY) 納入仕様書	No.	151-ENG-0813
SUBJECT 品名	RF FRONT-END SYSTEM UNIT RFフロントエンドシステムユニット	PAGE	11 OF 14
	ENG36A04G	DATE 日付	28.MAR.2003

Test Items 試験項目	Test Conditions 試験条件	Specifications 規格		
9. Phase Characteristics 位相特性		Over shoot オーバーシュート MAX. (%)	Under shoot アンダーシュート MAX. (%)	Vertical sag 垂直サグ MAX. (%)
		12.0	15.0	8.0
10. Differential phase 微分位相(DP)	Input : 80 dB μ 入力 Ch 12 Video mod.: 87.5 % 映像変調	MAX. (deg) <u>± 12.0</u>		
11. Differential gain 微分利得(DG)	Input : 80 dB μ 入力 Ch 12 Video mod.: 87.5 % 映像変調	MAX. (%) <u>± 12.0</u>		
12. SIF OUT PUT LEVEL SIF 出力	CH12 INPUT LEVEL 80dB μ P/S=10dB Mod. OFF No Terminate use high Impedance probe	<u>95 \pm 10 dBμ</u>		
13. C/S Beat C/Sビート	Fm=400Hz 100% Input level 入力 : 86dB μ Video mod. 映像変調 : 87.5% Video signal color bar 標準カラー信号 Ch 12	<u>P / S Ratio MAX. 5 d B</u>		
14. Video over Modulation	Input level 80dB μ Video Signal: White Window 映像信号 : 白ウィンドウ Ch 12	<u>90 % MIN</u>		

MATSUSHITA ELECTRONIC COMPONENTS CO., LTD. MODULE DEVICE COMPANY.	
--	--

CLASSIFICATION 標準書名	PRODUCTS SPECIFICATION (FOR SUPPLY) 納入仕様書	No.	151-ENG-0813
SUBJECT 品名		PAGE	12 OF 14
		DATE 日付	28.MAR.2003
RF FRONT-END SYSTEM UNIT RFフロントエンドシステムユニット		ENG36A04G	

Test Items 試験項目	Test Conditions 試験条件	Specifications 規格
15. Audio output level 音声出力	fm = 400Hz load 100k 負荷	<u>500 ± 250mVrms, ± 25kHz deviation</u> 偏 移
16. Audio S/N 音声バズ	fm = 1kHz Input 入力 : 80 dB μ Video mod. 映像変調 : 87.5 % Video signal color bar 標準カラ - バ - 信号	<u>MIN : 38 dB (P / S = 6 dB)</u> NOISE METER : Q-RMS, WIDE BAND
17. Audio distortion 音声歪率	fm = 400Hz load 100k 負荷 Video mod. off 映像無変調 Input 入力 : 75 dB μ	<u>Deviation</u> <u>± 7.5 kHz 偏 移 MAX . 3 %</u> <u>deviation</u> <u>± 25 kHz 偏 移 MAX . 2 %</u>
18. Audio frequency Characteristics 音声周波数特性	at 400Hz = 0dB $\Delta = \pm 7.5\text{kHz}/\text{Dev}$	<u>0.07 ~ 100 kHz : -5 ~ +2 dB</u>

MATSUSHITA ELECTRONIC COMPONENTS CO., LTD.. MODULE DEVICE COMPANY.	
---	--

CLASSIFICATION 標準書名	PRODUCTS SPECIFICATION (FOR SUPPLY) 納入仕様書	No.	151-ENG-0813
SUBJECT 品名		PAGE	13 OF 14
		DATE 日付	28.MAR.2003
		ENG36A04G	

7 Reliability
信頼性

Test Items 試験項目	Test Conditions 試験条件	Specifications 規格
1. Lightning resistance 耐雷性		There shall be no trouble when mounted. セット実装にて実用上問題のないこと。
2. Load life in humidity 耐湿負荷寿命		Shall satisfy the following values against the initial values when left for 1 hour in the normal temperature and humidity condition after being taken out from the thermostatic tank of 40 90~95% humidity 110% rated voltage is applied for specified time. 40 90~95% B 電圧 10%up 負荷で 1000h ライフ後常温常湿中に 1 h 放置し、実用上問題のないこと。
3. Low temperature storage kept 低温保存温度		Shall satisfy the electrical and mechanical characteristics after kept in -40 condition for 500hours. -40 500h 保存後、電気特性、機械特性に支障のないこと。
4. Load life in high temperature 高温負荷寿命		Shall satisfy the following values against the initial values when left for 1 hour in the normal temperature and humidity condition after being taken out from the thermostatic tank of 60 ,where 100% rated voltage is applied for specified time. 温度 60 の高温槽内に投入し、定格の 100%の負荷を規定時間(96h)印加した後、槽より取り出し常温常湿中に 1 h 放置し、実用上問題のないこと。
5. Heat resistance of solder flow フロー半田耐熱性		There shall be no trouble in MAX.260 and MAX.10 sec the practical operation. MAX . 2 6 0 MAX . 1 0 秒のフロー半田付けに於いて、実用上問題のないこと。

MATSUSHITA ELECTRONIC COMPONENTS CO., LTD..
MODULE DEVICE COMPANY.

CLASSIFICATION 標準書名	PRODUCTS SPECIFICATION (FOR SUPPLY) 納入仕様書	No.	151-ENG-0813
SUBJECT 品名		PAGE	14 OF 14
		DATE 日付	28.MAR.2003

ENG36A04G

8 Mechanical characteristics
機構特性

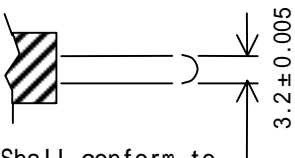
Test Items 試験項目	Test Conditions 試験条件	Specifications 規格
1. Holding strength of Phono Jack ピノック保持力	Test pin shape 試験ピン形状  Shall conform to RC-5231 of EIAJ standard. E I A J 規格 R C - 5 2 3 1 に準拠	Initial inserting force MAX. 49.0N 初期挿入力 Extracting force after 5 cycle MIN. 0.8N 5 回挿抜後の抜去力

MATSUSHITA ELECTRONIC COMPONENTS CO., LTD..
MODULE DEVICE COMPANY.

CLASSIFICATION 標準書名	PRODUCTS SPECIFICATION (FOR SUPPLY) 納入仕様書	No.	151-ENG-0813
SUBJECT 品名	RF FRONT-END SYSTEM UNIT RFフロントエンドシステムユニット	PAGE	1 OF 1
	ENG36A04G	DATE 日付	28.MAR.2003

www.datasheet4u.com

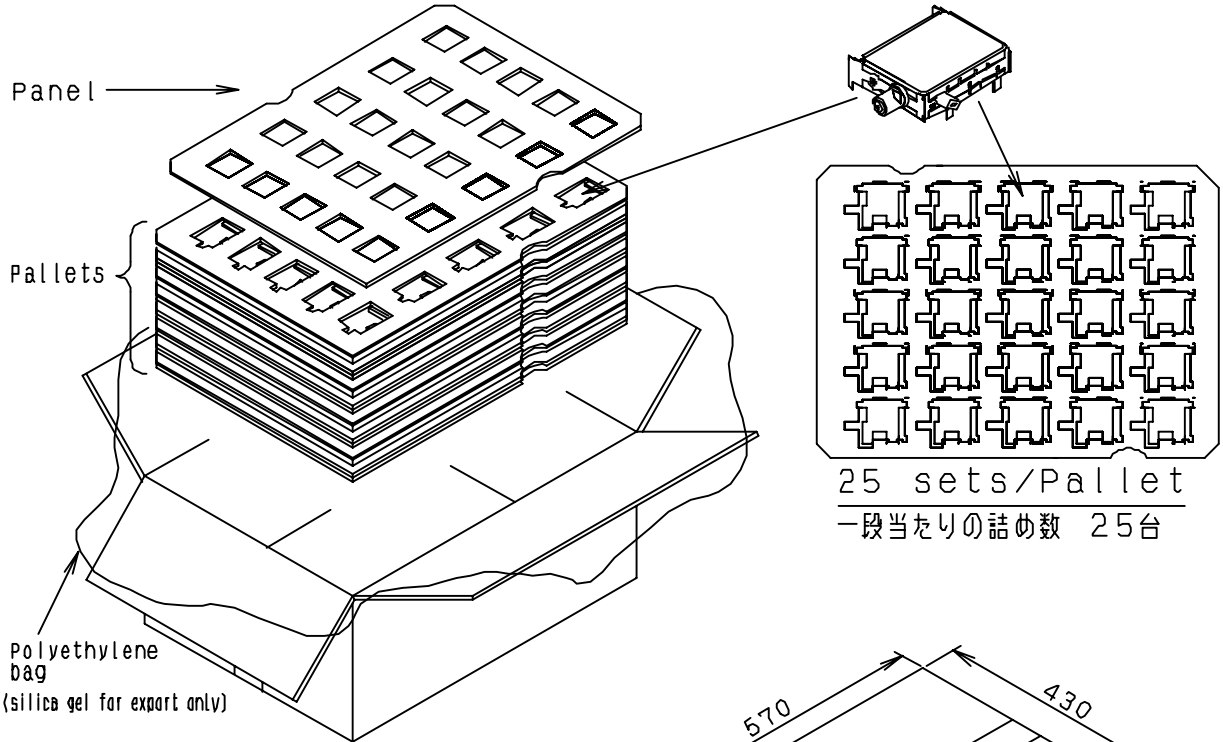

8 Pallets/Box (200 sets/Box)
製品は 8段積みとし、200台詰めとする

Product	Product Name
Model	Matsushita Part No.
Quantity	Quantity Pcs.
Production Date/Lot No.	Production Date/Lot No.
For Customer	Customer Name
Customer code	Customer Code
P/O No.	P/O No.
Packing Date	Packing Date

ex. 表示例(タイ製)
indication detail (in Thailand)

箱外寸 Packing size	570*430*220 (mm)
数量 Quantity	200 pcs/box

MATSUSHITA ELECTRONIC COMPONENTS CO., LTD..
HIGH FREQUENCY PRODUCTS DIVISION.

LIST OF PLASTIC MATERIALS

TYPE NO.

ENG36A04G

1 / 1

PARTS	MATERIALS		MAKER	ADDRESS	UL94 FLAME CLASS	UL FILE NO.	REMARKS	
	GENERAL NAME	COMMERCIAL NAME						
Printed Wiring Board <<size>> 60.2 x 43.2 x 1.0 mm www.datasheet4u.com	Phenol Resin Laminates	R-8700	Matsushita Electric Works Ltd	1048 Kadoma Kadoma-shi, Osaka 571-8686 Japan	94V-0	E81336	BSI NO.6369 JET NO.V-0055	
	or	Phenol Resin Laminates	CCP-3400	Chang Chun Plastics Co.,Ltd.	7th FL 301 Songkiang Rd, Taipei Taiwan	94V-0	E108591	BSI NO.6806 JET NO.V-0048
	or	Phenol Resin Laminates	ETL-XPC-801	Eternal Chemical Co.,Ltd.	578 Chien-kung Rd, Kaohsiung Taiwan	94V-0	E95862	BSI NO.6927 JET NO.V-0084
	or	Phenol Resin Laminates	PLC-2147	Sumitomo Bakelite Co Ltd Corporate Technical Div	Tennouzu Park Side Bldg 2-5-8 Higashishinagawa Shinagawa-ku, Tokyo 140-0002 Japan	94V-0	E95831	BSI NO.5193 JET NO.V-0006
	or	Phenol Resin Laminates	MCL-437F	Hitachi Chemical (Johor) Sdn. Bhd.	PLO 458, Jalan Keluli 10, P.O. Box 107, 81700 Pasir Gudang, Johor Darul Takzim, Malaysia.	94V-0	E80148	BSI NO.5145 JET NO.V-0015
	or	Phenol Resin Laminates	ETL-XPC-207	Eternal Chemical Co.,Ltd.	578 Chien-kung Rd, Kaohsiung Taiwan	94V-0	E95862	BSI NO.6927 JET NO.V-0084
	or	Phenol Resin Laminates	DS-1108	Doosan Electro Materials Co.,Ltd.	39-3 Seongbok-Ri, Suji-Eup, Yongin-Shi, Kyunggi-Do, 448-840 Korea	94V-0	E103670	BSI NO.6741 JET NO.V-0033
	or	Phenol Resin Laminates	NS-6732G	Shinsung Industrial Co.,Ltd.	153, Gongda-Dong, Gumi-City, Kyungbuk korea.	94V-0	E65931	BSI NO.8653
	Terminal Plate	or	Polyamide (PA46)	DSM JSR ENGINEERING PLASTICS KK	Yoneda Bldg, 6th FL 6-17-20 Shinbashi Minato-ku, Tokyo 105-0004 Japan	94V-0	E172082	
		Polyamide (PA46)	DSM JSR ENGINEERING PLASTICS KK	Yoneda Bldg, 6th FL 6-17-20 Shinbashi Minato-ku, Tokyo 105-0004 Japan	94V-0	E172082		

MATSUSHITA ELECTRONIC COMPONENTS CO., LTD.
MODULE DEVICE COMPANY
MODULE BUSINESS UNIT

APPROVAL

CHECK

DESIGN

T.KOBAYASHI
Jan 08, 2004

M.KANBA
Jan 08, 2004

M.KANBA
Jan 08, 2004

LIST OF PRINTED MAKER

TYPE NO.

ENG36A04G

1 / 2

PARTS	PRINTED MAKER	ADDRESS	UL FILE NO.	TRADE-MARK AND TYPE DESIGNATION	UL94 FLAME CLASS	MATERIALS		MAKER										
						GENERAL NAME	COMMERCIAL NAME											
Printed Wiring Board www.datasheet4u.com	Matsushita Electric Industrial Co Ltd	Matsushita Electric Corp of America 1 Panasonic Way, Secaucus NJ 07094	E36779	M EAMX5	94V-0	Phenol Resin Laminates	R-8700	Matsushita Electric Works Ltd										
				M TEAMX5														
				M NEAMX5														
	CMK CORP	1106 Fujikubo Miyoshi-machi Iruma-gun, Saitama-ken 354-8580 Japan	E41363	M EAMX5	94V-0	Phenol Resin Laminates	CCP-3400	Chang Chun Plastics Co.,Ltd.										
				M TEAMX5														
				M NEAMX5														
				M EAMX5					94V-0	Phenol Resin Laminates	ETL-XPC-801	Eternal Chemical Co.,Ltd.						
				M TEAMX5														
				M NEAMX5														
Nippon Elec Co Ltd	17-14 Himonya 5-chome Meguro-ku, Tokyo 152-0003 Japan	E41166	NE M PF1	94V-0	Phenol Resin Laminates	R-8700	Matsushita Electric Works Ltd											
			NE 49S															
			NE M PFS															
			Pentex Circuits Private Ltd					11 Penjuru Ln, Singapore 2260 Singapore	E68999	PCL 27	94V-0	Phenol Resin Laminates	R-8700	Matsushita Electric Works Ltd				
										PCL 35					94V-0	Phenol Resin Laminates	ETL-XPC-801	Eternal Chemical Co.,Ltd.
Eurocir S A	AV Salvatella 51-57 P I Barbera Del Valles 08219 Barbera, Barcelona Spain	E140565	10B	94V-0	Phenol Resin Laminates	R-8700	Matsushita Electric Works Ltd											

MATSUSHITA ELECTRONIC COMPONENTS CO., LTD.
 MODULE DEVICE COMPANY
 MODULE BUSINESS UNIT

APPROVAL	CHECK	DESIGN
T.KOBAYASHI Jan 08, 2004	M.KANBA Jan 08, 2004	M.KANBA Jan 08, 2004

LIST OF PRINTED MAKER				TYPE NO.		ENG36A04G		2 / 2		
PARTS	PRINTED MAKER	ADDRESS	UL FILE NO.	TRADE-MARK AND TYPE DESIGNATION	UL94 FLAME CLASS	MATERIALS		MAKER		
						GENERAL NAME	COMMERCIAL NAME			
Printed Wiring Board	Suzhou Matsushita Electric Works Printed Wiring Board Co Ltd	1 Huai Hai St Suzhou New District, Suzhou Jiangsu China	E164387	SMEW N870A-T	94V-0	Phenol Resin Laminates	R-8700	Matsushita Electric Works Ltd		
	Kyosha Co Ltd	Mori Kumiyama-cho Kuse-gun, Kyoto 613-0024 Japan	E55888	KPC-M-PP	94V-0	Phenol Resin Laminates	R-8700	Matsushita Electric Works Ltd		
				KPC-M-PP	94V-0	Phenol Resin Laminates	CCP-3400	Chang Chun Plastics Co.,Ltd.		
				KPC-M-PP	94V-0	Phenol Resin Laminates	MCL-437F	Hitachi Chemical (Johor) Sdn. Bhd.		
	PT. Hitachi Chemical Electronic Products Indonesia	JL. Palem 2 Blok DS No.12 Lippo Cikarang, Bekasi 17550 Indonesia	E41480	H-C 140MA	94V-0	Phenol Resin Laminates	R-8700	Matsushita Electric Works Ltd		
				H-C 140HI	94V-0	Phenol Resin Laminates	MCL-437F	Hitachi Chemical (Johor) Sdn. Bhd.		
	Pentex-schweizer Electronics Pte Ltd.	55 Penjuru Road Shingapore 609140	E88234	PCL-27	94V-0	Phenol Resin Laminates	R-8700	Matsushita Electric Works Ltd		
				PCL-35	94V-0	Phenol Resin Laminates	ETL-XPC-207	Eternal Chemical Co.,Ltd.		
				PCL-35	94V-0	Phenol Resin Laminates	DS-1108	Doosan Electro Materials Co.,Ltd.		
				PCL-27	94V-0	Phenol Resin Laminates	NS-6732G	Shinsung Industrial Co.,Ltd.		
	PNE PCB SDN BHD	No.6, Jalan Firma 2/1, Kawasan Perindustrian Tebrau, 8100 Johor Bahru, Johor, Malaysia.	E67640	PNE-1B1	94V-0	Phenol Resin Laminates	R-8700	Matsushita Electric Works Ltd		
				PNE-1B1	94V-0	Phenol Resin Laminates	MCL-437F	Hitachi Chemical (Johor) Sdn. Bhd.		
				PNE-1B1	94V-0	Phenol Resin Laminates	ETL-XPC-207	Eternal Chemical Co.,Ltd.		
				PNE-1B1	94V-0	Phenol Resin Laminates	DS-1108	Doosan Electro Materials Co.,Ltd.		
	Draco PCB Public Company Limited	Bangkadi Industrial Park, 152 Mu5, Tiwanon Road, Amphur Muang, Pathumthani 12000, Thailand	E216636	DPC38	94V-0	Phenol Resin Laminates	R-8700	Matsushita Electric Works Ltd		
				DPC18	94V-0	Phenol Resin Laminates	PLC-2147	Sumitomo Bakelite Co Ltd Corporate Technical Div		
				DPC38	94V-0	Phenol Resin Laminates	MCL-437F	Hitachi Chemical (Johor) Sdn. Bhd.		
	MATSUSHITA ELECTRONIC COMPONENTS CO., LTD. MODULE DEVICE COMPANY MODULE BUSINESS UNIT							APPROVAL	CHECK	DESIGN
								T.KOBAYASHI	M.KANBA	M.KANBA
Jan 08, 2004								Jan 08, 2004	Jan 08, 2004	

General Dimension Tolerance	Sym.	Date	Revision	Signed/Checked
±1.0				

Maximum Dimension of Pin-Plug

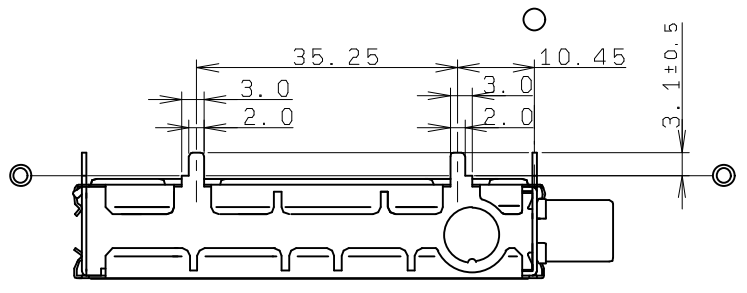
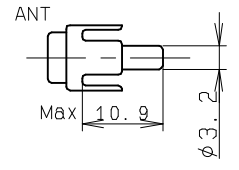

Maximum Dimension of Screw

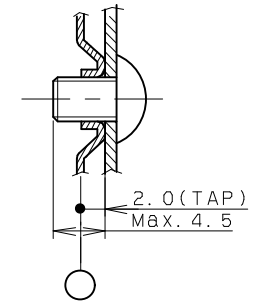

www.datasheet4u.com

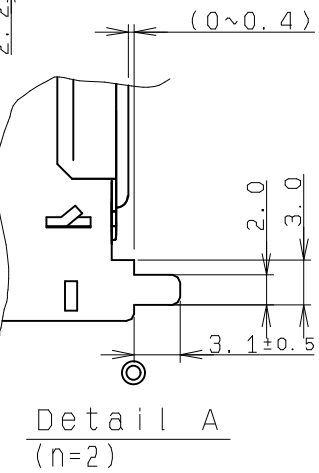
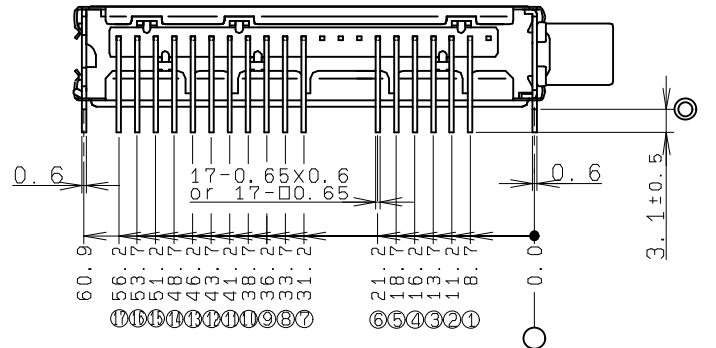
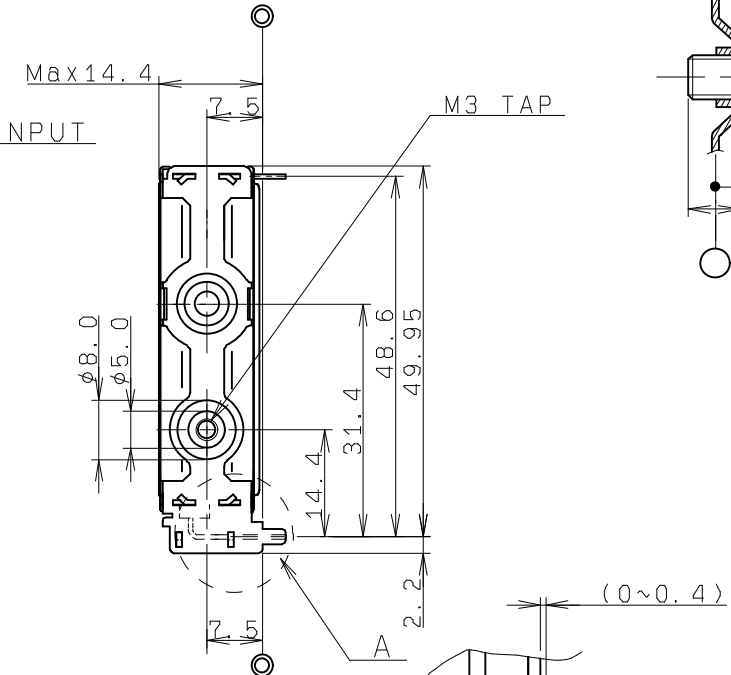
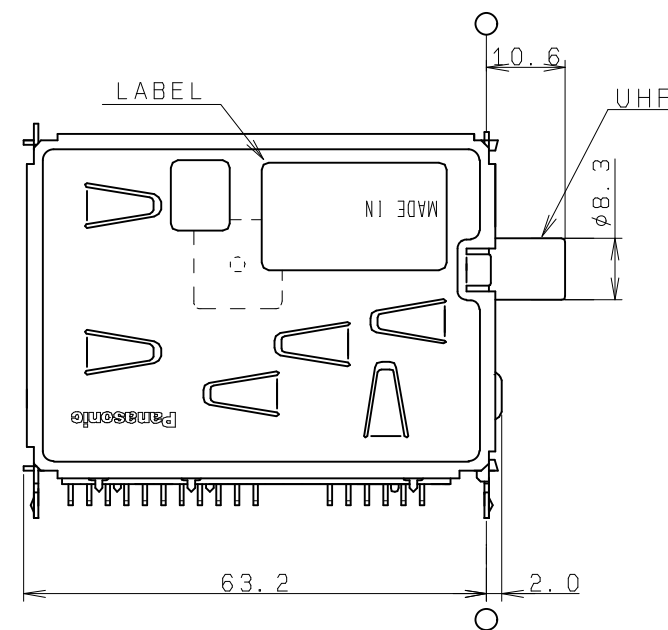
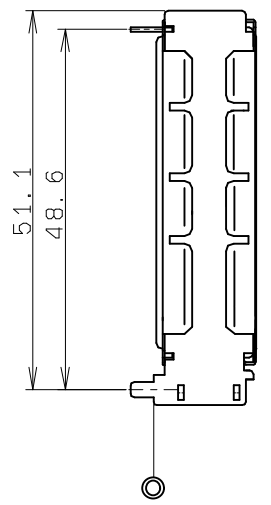

TERMINAL NAME	SUPPLY VOLTAGE
1	NC
2	NC
3	+B 5.0 V
4	NC
5	NC
6	NC
7	BT
8	NC
9	IF out
10	SCL
11	SDA
12	NC
13	Audio out
14	SIF out
15	NC
16	NC
17	Video out

*12: DO NOT CONNECT

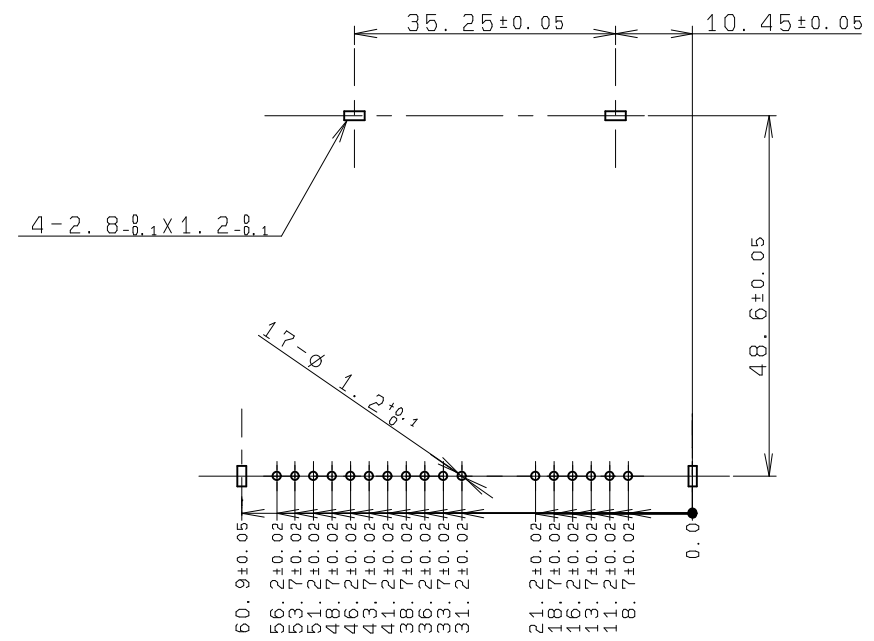

TERMINAL CHECK GAUGE
TOP(TUNER) SIDE VIEW

LABEL
The Country of Origin: ENG36A04G
MADE IN THAILAND
Lot No. ex 30 19
3... YEAR(2003)
0... MONTH
O... OCT.
N... NOV.
D... DEC.
19... DAY

ENG36A04G					
Sym.	Item or Code No.	Material & Size	qt.	Process	Remark
				Model	VP-13 Horizontal
				Name	PRODUCT SPECIFICATION
				No.	DM17-1405-00
Scale	Designed	Drawn	Traced	Checked	Approved
1/1	M. KANBA 10. OCT. '03	M. KANBA 10. OCT. '03		M. KANBA 10. OCT. '03	T. KOBAYASHI 10. OCT. '03

8 www.datasheet4u.com

7

6

5

4

3

2

1

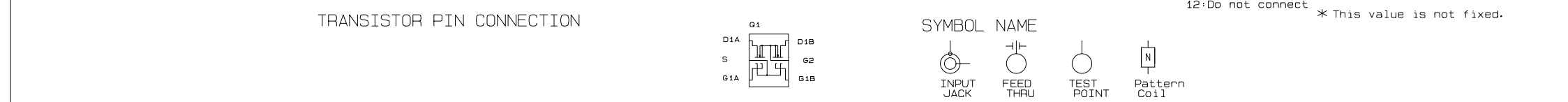
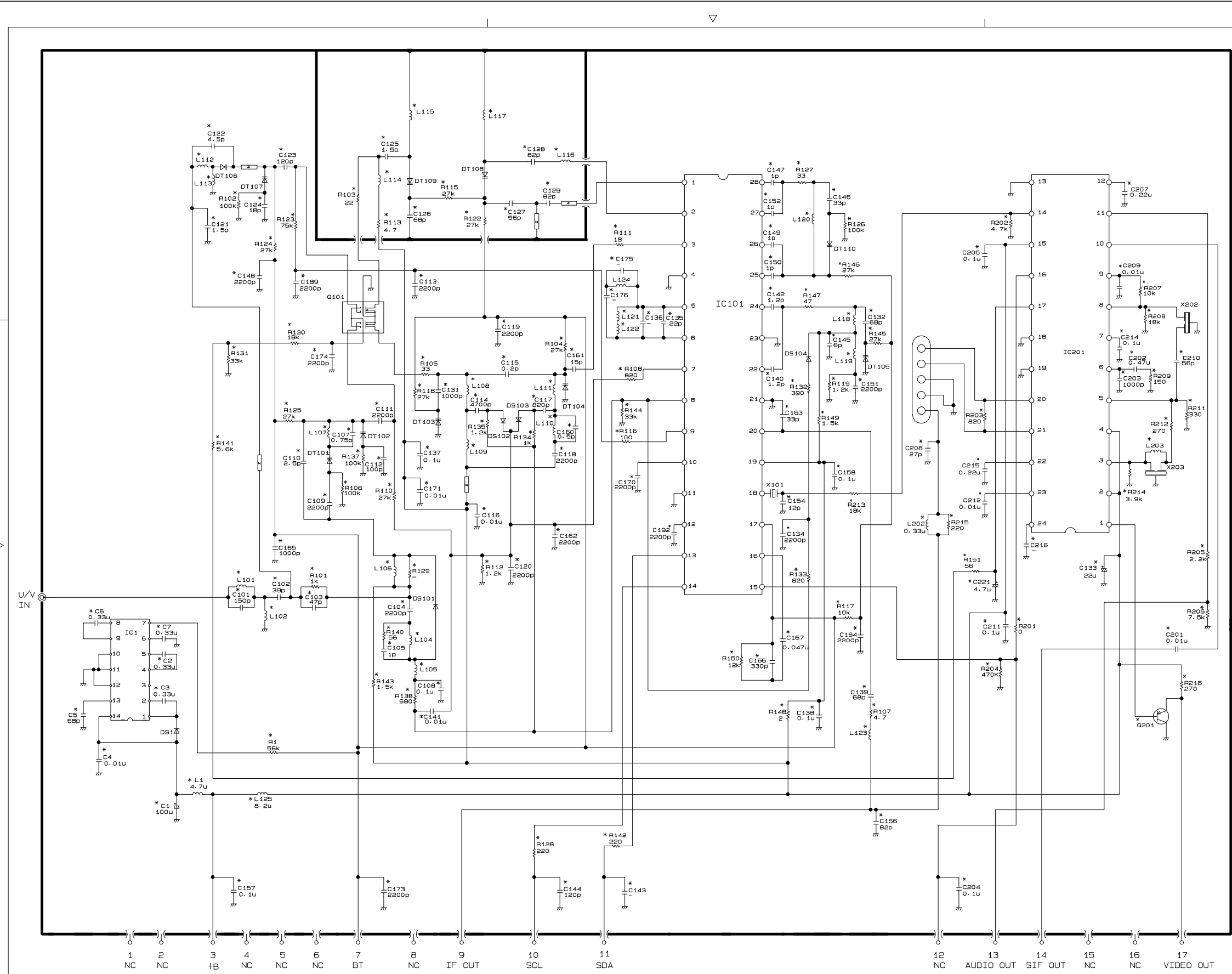

Sym.	Date	Revision	Sign	Check.

TERMINAL SUPPLY VOLTAGE

Terminal No.	Terminal Name	Supply Voltage (v)
1	NC	---
2	NC	---
3	+B	5.0V
4	NC	---
5	NC	---
6	NC	---
7	BT	---
8	NC	---
9	IF OUT	---
10	SCL	---
11	SDA	---
12	NC	---
13	AUDIO OUT	---
14	SIF OUT	---
15	NC	---
16	NC	---
17	VIDEO OUT	---
18		
19		
20		
21		
22		
23		
24		
25		

SYMBOL

Symbol	Symbol No.	Semiconductor
	R1, R101~R151, R201-216	resistance(Ω) except 108, 114, 120, 121, 136, 139,
	C1~C7, C101-C192, C201-221	capacitance(F) except 106, 130, 133, 158, 159, 168,
	L1, L101~L125, L202~L203	inductance(H) except 103
	DS1	MA2677, 1S53B1
	DT101-DT105	MA25C357, BB659C, BB187 HVC306A, 15V283, 1T404
	DT106-DT110	MA25372, BB655 15V278, 1T402, BB179
	Q101	TBB1004, BF1203
	Q201	2SB1218A
	IC101	MT404
	IC201	MB1111FP
	IC1	LA7995
	X101	4MHZ
	X201	M1B68D, M1B67D
	X202	SFSH4R5/EFCS4R5YS
	X203	TPS4R5/EFCS4R5MW

Type No. ENG36A04G

Designed	Drawn	Traced	Checked	Approved
K. Okuda	A. takahashi		K. Fujita	K. Sato
'03.02.17	'03.03.31			

Name CONNECTION DIAGRAM

No. DM18-1380-00

PLL Data Table VP13 (ENG36A04G)

IF = 45.75 MHz

EX) Step size

www.datasheet4u.com 31.25 (kHz)

Channel	Picture Carrier (MHz)	fosc (MHz)	fosc/step size	Byte1	Hex. Byte2 Byte3	Byte4	Byte5
2	55.25	101	3232	C0	0CA0	CA	01
3	61.25	107	3424	C0	0D60	CA	01
4	67.25	113	3616	C0	0E20	CA	01
5	77.25	123	3936	C0	0F60	CA	01
6	83.25	129	4128	C0	1020	CA	01
A-5	91.25	137	4384	C0	1120	CA	01
A-4	97.25	143	4576	C0	11E0	CA	01
A-3	103.25	149	4768	C0	12A0	CA	01
A-2	109.25	155	4960	C0	1360	CA	01
A-1	115.25	161	5152	C0	1420	CA	01
A	121.25	167	5344	C0	14E0	CA	01
B	127.25	173	5536	C0	15A0	CA	01
C	133.25	179	5728	C0	1660	CA	02
D	139.25	185	5920	C0	1720	CA	02
E	145.25	191	6112	C0	17E0	CA	02
F	151.25	197	6304	C0	18A0	CA	02
G	157.25	203	6496	C0	1960	CA	02
H	163.25	209	6688	C0	1A20	CA	02
I	169.25	215	6880	C0	1AE0	CA	02
7	175.25	221	7072	C0	1BA0	CA	02
8	181.25	227	7264	C0	1C60	CA	02
9	187.25	233	7456	C0	1D20	CA	02
10	193.25	239	7648	C0	1DE0	CA	02
11	199.25	245	7840	C0	1EA0	CA	02
12	205.25	251	8032	C0	1F60	CA	02
13	211.25	257	8224	C0	2020	CA	02
J	217.25	263	8416	C0	20E0	CA	02
K	223.25	269	8608	C0	21A0	CA	02
L	229.25	275	8800	C0	2260	CA	02
M	235.25	281	8992	C0	2320	CA	02
N	241.25	287	9184	C0	23E0	CA	02
O	247.25	293	9376	C0	24A0	CA	02
P	253.25	299	9568	C0	2560	CA	02
Q	259.25	305	9760	C0	2620	CA	02
R	265.25	311	9952	C0	26E0	CA	02
S	271.25	317	10144	C0	27A0	CA	02
T	277.25	323	10336	C0	2860	CA	02

IF = 45.75 MHz

EX) Step size
31.25 (kHz)

www.datasheet4u.com

Channel	Picture Carrier (MHz)	fosc (MHz)	fosc/step size	Byte1	Hex. Byte2 Byte3	Byte4	Byte5
U	283.25	329	10528	C0	2920	CA	02
V	289.25	335	10720	C0	29E0	CA	02
W	295.25	341	10912	C0	2AA0	CA	02
AA	301.25	347	11104	C0	2B60	CA	02
BB	307.25	353	11296	C0	2C20	CA	02
CC	313.25	359	11488	C0	2CE0	CA	02
DD	319.25	365	11680	C0	2DA0	CA	02
EE	325.25	371	11872	C0	2E60	CA	02
FF	331.25	377	12064	C0	2F20	CA	02
GG	337.25	383	12256	C0	2FE0	CA	02
HH	343.25	389	12448	C0	30A0	CA	02
II	349.25	395	12640	C0	3160	CA	02
JJ	355.25	401	12832	C0	3220	CA	02
KK	361.25	407	13024	C0	32E0	CA	02
LL	367.25	413	13216	C0	33A0	CA	08
MM	373.25	419	13408	C0	3460	CA	08
NN	379.25	425	13600	C0	3520	CA	08
OO	385.25	431	13792	C0	35E0	CA	08
PP	391.25	437	13984	C0	36A0	CA	08
QQ	397.25	443	14176	C0	3760	CA	08
RR	403.25	449	14368	C0	3820	CA	08
SS	409.25	455	14560	C0	38E0	CA	08
TT	415.25	461	14752	C0	39A0	CA	08
UU	421.25	467	14944	C0	3A60	CA	08
VV	427.25	473	15136	C0	3B20	CA	08
WW	433.25	479	15328	C0	3BE0	CA	08
AAA	439.25	485	15520	C0	3CA0	CA	08
BBB	445.25	491	15712	C0	3D60	CA	08
CCC	451.25	497	15904	C0	3E20	CA	08
DDD	457.25	503	16096	C0	3EE0	CA	08
EEE	463.25	509	16288	C0	3FA0	CA	08
FFF	469.25	515	16480	C0	4060	CA	08
14	471.25	517	16544	C0	40A0	CA	08
15	477.25	523	16736	C0	4160	CA	08
16	483.25	529	16928	C0	4220	CA	08
17	489.25	535	17120	C0	42E0	CA	08
18	495.25	541	17312	C0	43A0	CA	08

IF = 45.75 MHz

EX) Step size
31.25 (kHz)

www.datasheet4u.com

Channel	Picture Carrier (MHz)	fosc (MHz)	fosc/step size	Byte1	Hex. Byte2 Byte3	Byte4	Byte5
19	501.25	547	17504	C0	4460	CA	08
20	507.25	553	17696	C0	4520	CA	08
21	513.25	559	17888	C0	45E0	CA	08
22	519.25	565	18080	C0	46A0	CA	08
23	525.25	571	18272	C0	4760	CA	08
24	531.25	577	18464	C0	4820	CA	08
25	537.25	583	18656	C0	48E0	CA	08
26	543.25	589	18848	C0	49A0	CA	08
27	549.25	595	19040	C0	4A60	CA	08
28	555.25	601	19232	C0	4B20	CA	08
29	561.25	607	19424	C0	4BE0	CA	08
30	567.25	613	19616	C0	4CA0	CA	08
31	573.25	619	19808	C0	4D60	CA	08
32	579.25	625	20000	C0	4E20	CA	08
33	585.25	631	20192	C0	4EE0	CA	08
34	591.25	637	20384	C0	4FA0	CA	08
35	597.25	643	20576	C0	5060	CA	08
36	603.25	649	20768	C0	5120	CA	08
37	609.25	655	20960	C0	51E0	CA	08
38	615.25	661	21152	C0	52A0	CA	08
39	621.25	667	21344	C0	5360	CA	08
40	627.25	673	21536	C0	5420	CA	08
41	633.25	679	21728	C0	54E0	CA	08
42	639.25	685	21920	C0	55A0	CA	08
43	645.25	691	22112	C0	5660	CA	08
44	651.25	697	22304	C0	5720	CA	08
45	657.25	703	22496	C0	57E0	CA	08
46	663.25	709	22688	C0	58A0	CA	08
47	669.25	715	22880	C0	5960	CA	08
48	675.25	721	23072	C0	5A20	CA	08
49	681.25	727	23264	C0	5AE0	CA	08
50	687.25	733	23456	C0	5BA0	CA	08
51	693.25	739	23648	C0	5C60	CA	08
52	699.25	745	23840	C0	5D20	CA	08
53	705.25	751	24032	C0	5DE0	CA	08
54	711.25	757	24224	C0	5EA0	CA	08
55	717.25	763	24416	C0	5F60	CA	08

IF = 45.75 MHz

EX) Step size
31.25 (kHz)

www.datasheet4u.com

Channel	Picture Carrier (MHz)	fosc (MHz)	fosc/step size	Byte1	Hex. Byte2	Hex. Byte3	Byte4	Byte5
56	723.25	769	24608	C0	6020	CA	08	
57	729.25	775	24800	C0	60E0	CA	08	
58	735.25	781	24992	C0	61A0	CA	08	
59	741.25	787	25184	C0	6260	CA	08	
60	747.25	793	25376	C0	6320	CA	08	
61	753.25	799	25568	C0	63E0	CA	08	
62	759.25	805	25760	C0	64A0	CA	08	
63	765.25	811	25952	C0	6560	CA	08	
64	771.25	817	26144	C0	6620	CA	08	
65	777.25	823	26336	C0	66E0	CA	08	
66	783.25	829	26528	C0	67A0	CA	08	
67	789.25	835	26720	C0	6860	CA	08	
68	795.25	841	26912	C0	6920	CA	08	
69	801.25	847	27104	C0	69E0	CA	08	