



## AME8753

## Low Dropout 500mA / 500mA Dual CMOS LDO Regulator

### ■ General Description

The AME8753 dual, low dropout, linear regulators operate from  $V_{OUT} + V_{DROPOUT}$  to 5.5V input and deliver up to 500mA / 500mA output current each. Low dropout voltage and low quiescent current (70 $\mu$ A typ.) make them ideal for battery applications.

The AME8753 is available with a wide variety of voltage options as standard and can be trimmed to 2% accuracy.

For protection purpose, AME8753 has both thermal shut-down and current fold-back to prevent device failure under the "Worst" operating conditions.

### ■ Features

- Very Low Dropout Voltage
- Guaranteed 500mA / 500mA Each Output
- Accurate to within 2% for both outputs
- Typical 70  $\mu$ A Quiescent Current
- Over-Temperature Shutdown
- Current Limiting
- Short Circuit Current Fold-back
- All AME' s Lead Free Products Meet RoHS Standards

### ■ Applications

- Cellular Phones
- Palm / Notebook
- Battery Power Equipment
- Handheld Instruments

### ■ Functional Block Diagram

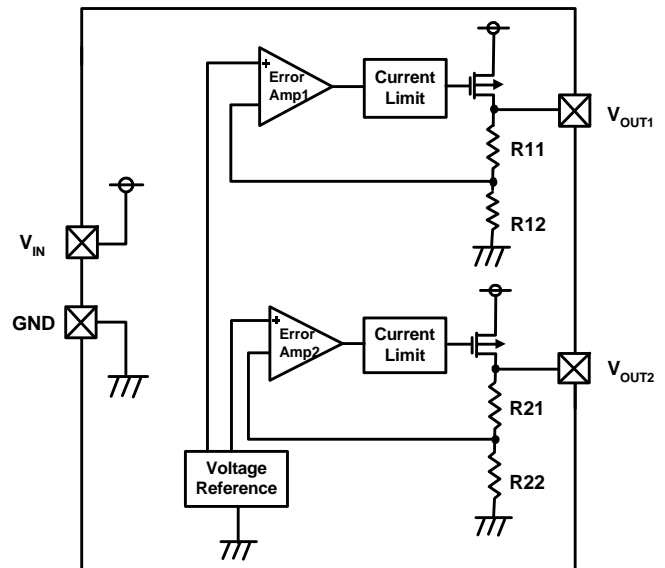

### ■ Typical Applications

Fixed Version

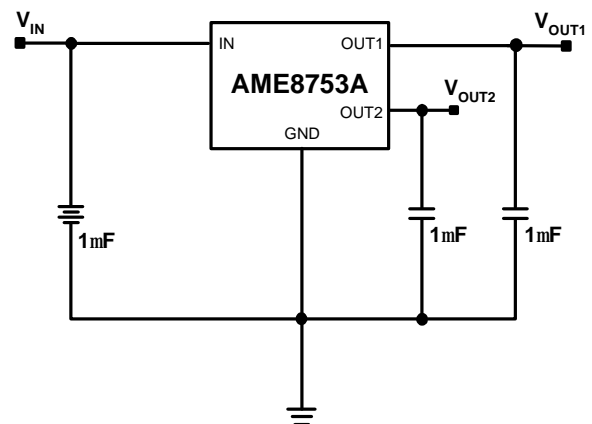

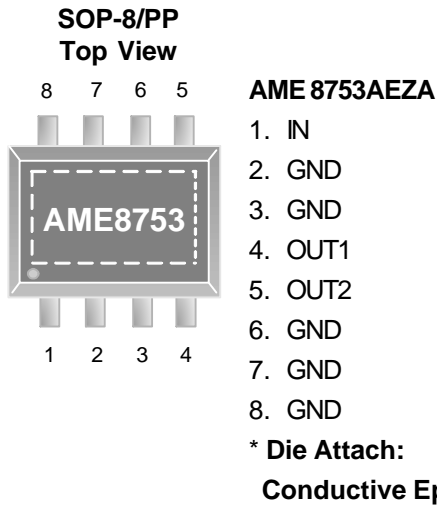
**■ Pin Configuration**

Note: The area enclosed by dashed line represents Exposed Pad and connection to GND.

**■ Pin Description**

Pin Number	Pin Name	Description
1	IN	Regulator Input. Supply voltage can range from Higher $V_{OUT} + V_{DROPOUT}$ to 5.5V. This input also supplies the on-chip reference. Bypass with a 1 $\mu$ F capacitor to GND.
2	GND	Ground. This pin also functions as heatsink. Solder to a large pad or the circuit-board ground plane to maximize thermal dissipation.
3	GND	Ground. This pin also functions as heatsink. Solder to a large pad or the circuit-board ground plane to maximize thermal dissipation.
4	OUT1	Regulator 1 Output. Sources up to 500mA continuous current. Bypass with a 1 $\mu$ F (< 0.5 $\Omega$ typ ESR) capacitor to GND.
5	OUT2	Regulator 2 Output. Sources up to 500mA continuous current. Bypass with a 1 $\mu$ F (< 0.5 $\Omega$ typ ESR) capacitor to GND.
6	GND	Ground. This pin also functions as heatsink. Solder to a large pad or the circuit-board ground plane to maximize thermal dissipation.
7	GND	Ground. This pin also functions as heatsink. Solder to a large pad or the circuit-board ground plane to maximize thermal dissipation.
8	GND	Ground. This pin also functions as heatsink. Solder to a large pad or the circuit-board ground plane to maximize thermal dissipation.



■ Ordering Information

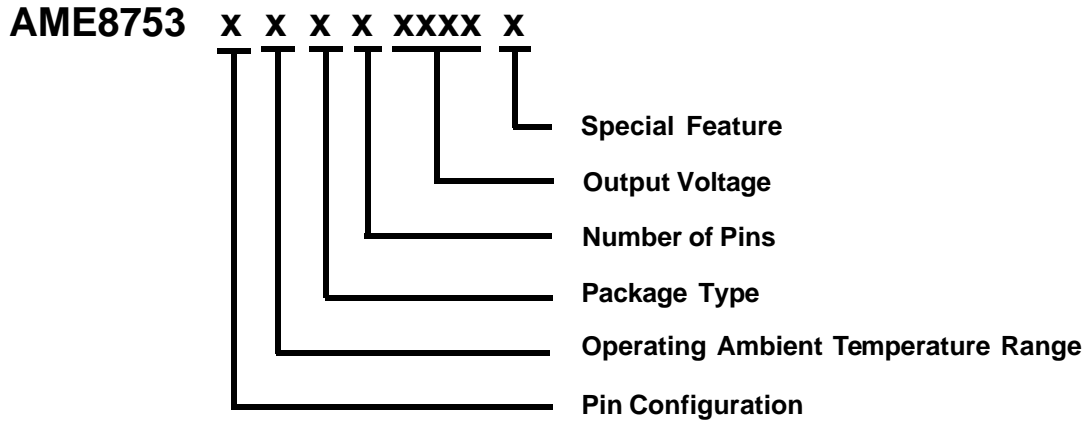

Pin Configuration	Operating Ambient Temperature Range	Package Type	Number of Pins	Output Voltage (Both LDOs)	Special Feature
A (SOP-8/PP) 1. IN 2. GND 3. GND 4. OUT1 5. OUT2 6. GND 7. GND 8. GND	E: -40°C to 85°C	Z: SOP/PP	A: 8	2533: V <sub>OUT1</sub> =2.5V V <sub>OUT2</sub> =3.3V	Z: Lead free

■ Ordering Information

Part Number	Marking*	Output Voltage	Package	Operating Ambient Temperature Range
AME8753AEZA2533Z	AME8753 AEZA2533 yyww	V <sub>OUT1</sub> =2.5V V <sub>OUT2</sub> =3.3V	SOP-8/PP	- 40°C to 85°C

Note:yyww represents date code .

\* a line on top of the first letter represents lead free plating such as  $\bar{A}$ ME8753.

Please consult AME sales office or authorized Rep./Distributor for voltage accuracy and package type availability.

**■ Absolute Maximum Ratings**

Parameter	Maximum	Unit
Input Voltage	-0.3 to 6	V
Output Voltage	-0.3 to $V_{IN} + 0.3$	V
Output Current	$P_D / [2V_{IN} - (V_{OUT1} + V_{OUT2})]$	mA
ESD Classification	C*	

Caution: Stress above the listed absolute maximum rating may cause permanent damage to the device

\* HBM C:4000V+

**■ Recommended Operating Conditions**

Parameter	Symbol	Rating	Unit
Ambient Temperature Range	$T_A$	-40 to 85	°C
Junction Temperature Range	$T_J$	-40 to 125	°C
Storage Temperature Range	$T_{STG}$	-65 to 150	°C

**■ Thermal Information**

Parameter	Package	Die Attach	Symbol	Maximum	Unit
Thermal Resistance * (Junction to Case)	SOP-8/PP	Conductive Epoxy	$\theta_{JC}$	19	°C / W
Thermal Resistance (Junction to Ambient)			$\theta_{JA}$	84	
Internal Power Dissipation			$P_D$	1450	mW
Maximum Junction Temperature				150	°C
Solder Iron (10 Sec)**				350	°C

\* Measure  $\theta_{JC}$  on center of molding compound if IC has no tab.

\*\* MIL-STD-202G 210F

**■ Electrical Specifications**

Unless specified:  $T_J=25^{\circ}\text{C}$ ,  $V_{IN}=\text{Higher } V_{OUT}+1\text{V}$ ,  $I_{OUT1}=I_{OUT2}=1\text{mA}$ ,  $C_{IN}=C_{OUT}=1\mu\text{F}$ .  
 Typical values are at  $T_J=25^{\circ}\text{C}$

Parameter	Symbol	Test Condition	Min	Typ	Max	Units
<b>IN</b>						
Input Supply Voltage	$V_{IN}$		Note1		5.5	V
Quiescent Current	$I_Q$			70	160	$\mu\text{A}$
<b>OUT1, OUT2</b>						
Output Voltage	$V_{OUT}$	$I_{OUT}=1\text{mA}$		-2%	2%	V
		$0\text{mA}<I_{OUT}\leq 500\text{mA}$ , $V_{OUT}+1\text{V}<V_{IN}<5.5\text{V}$	$T_J=-40^{\circ}\text{C}$ to $+125^{\circ}\text{C}$	-2.5%	2.5%	
Line Regulation	$\text{REG}_{LINE}$	$V_{OUT}+1\text{V}<V_{IN}<5.5\text{V}$ $I_{OUT}=1\text{mA}$		$T_J=25^{\circ}\text{C}$	0.2	% / V
				$T_J=-40^{\circ}\text{C}$ to $+125^{\circ}\text{C}$	-0.25	
Load Regulation	$\text{REG}_{LOAD}$	$1\text{mA}<I_{OUT}$	$T_J=-40^{\circ}\text{C}$ to $+125^{\circ}\text{C}$	-0.005	$\pm 0.0025$	% / mA
Dropout Voltage	$V_{DROP}$	$I_{OUT1}=I_{OUT2}=500\text{mA}$ $(V_O=V_{O(NOM)}-2\%)$ , $V_{O(NOM)}\geq 2.5\text{V}$	$T_J=-40^{\circ}\text{C}$ to $+125^{\circ}\text{C}$		800	mV
Current Limit	$I_{LIM}$		700		1400	mA
Short Circuit Current	$I_{SC}$			350	500	
Ripple Rejection	PSRR	$f=100\text{HZ}$ , $I_{OUT}=1\text{mA}$			55	dB
		$f=1\text{kHz}$ , $I_{OUT}=1\text{mA}$			55	
		$f=10\text{kHz}$ , $I_{OUT}=1\text{mA}$			48	
Output Voltage Noise	$e_n$	$f=1\text{kHz}$ to $100\text{kHz}$ , $C_{OUT}=1\mu\text{F}$			550	$\mu\text{V}_{RMS}$
<b>Over Temperature Protection</b>						
Over Temperature Shutdown	OTS			150		$^{\circ}\text{C}$
Over Temperature Hysteresis	OTH			20		$^{\circ}\text{C}$

Note1:  $V_{IN(min)}=\text{Higher } V_{OUT}+V_{Dropout}$



## ■ Detailed Description

The AME8753 is low-dropout, low quiescent-current linear regulator designed primarily for battery-powered applications. These parts are available with preset output voltage ranging from 2.5V to 3.3V, and the parts can supply loads up to 500mA.

### Internal P-Channel Pass Transistor

The AME8753 features two  $1\Omega$  P-Channel MOSFET pass transistors. A P-Channel MOSFET provides several advantages over similar designs using PNP pass transistors, including longer battery life. It requires no base drive, which reduces quiescent current significantly. The AME8753 only consumes  $70\mu\text{A}$  of quiescent current whether in dropout, light-load, or heavy-load applications.

### Current Limit

The AME8753 contains two independent current limiters, one for each regulator, which monitor and control the pass transistor's gate voltage, limiting output current to 700mA minimum. The output can be shorted to ground for an indefinite time without damaging the part.

### Thermal-Overload Protection

Thermal-overload protection limits total power dissipation in the AME8753. When the junction temperature exceeds  $T_j=150^\circ\text{C}$ , the thermal sensor signals the shutdown logic, turning off the pass transistor and allowing the IC to cool.

## ■ Application Information

### Capacitor Selection and Regulator Stability

Use a  $1\mu\text{F}$  capacitor on the AME8753 input and a  $1\mu\text{F}$  capacitor on the outputs. Larger input capacitor values and lower ESRs provide better supply noise rejection and line transient response.

### PSRR and Operation from Sources Other than Batteries

The AME8753 is designed to deliver low dropout voltages and low quiescent currents in battery powered systems. Power-supply rejection is 50dB at low frequencies.



Quiescent Current vs Input Voltage

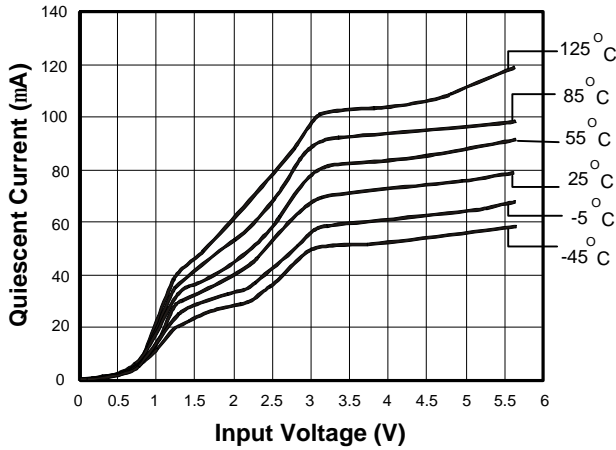

Channel-to-Channel Isolation (dB)

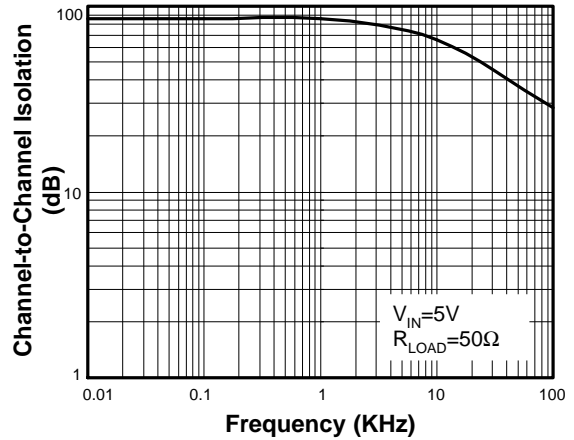

Quiescent Current vs Temperature

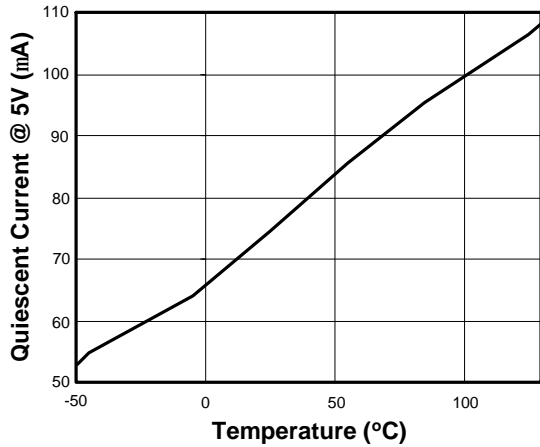

Output Noise Spectral Density

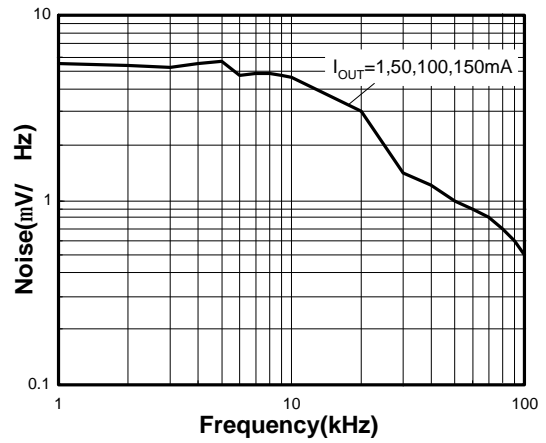

Dropout Voltage vs Load Current

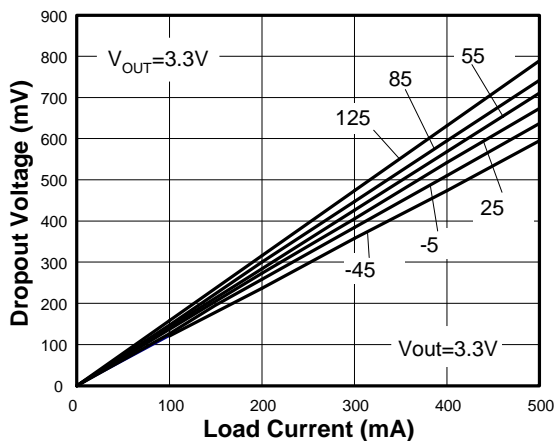

Line Transient

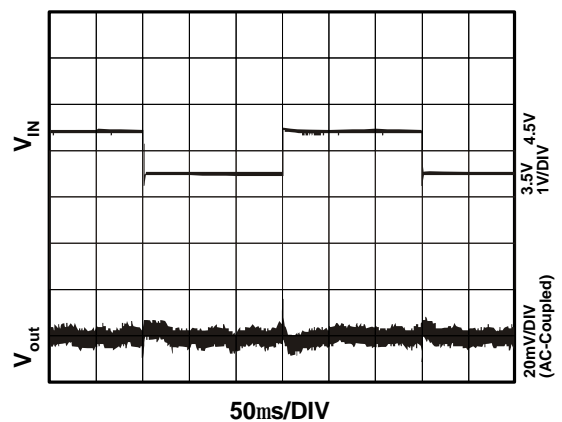

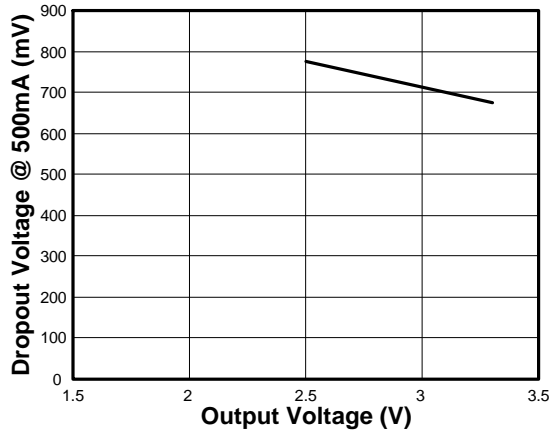
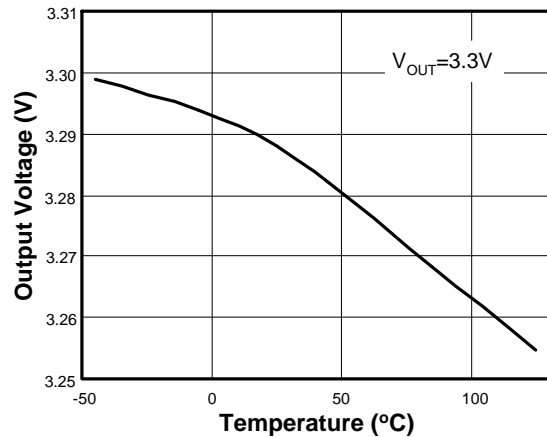
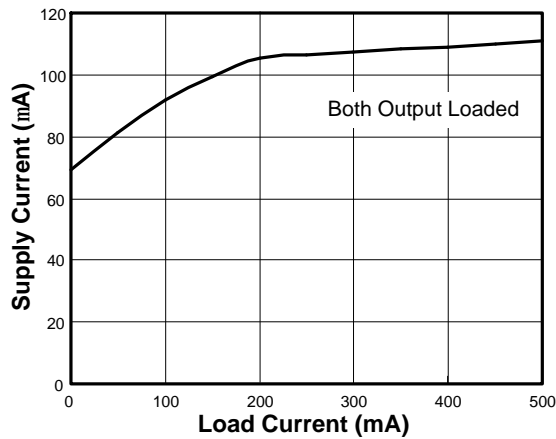
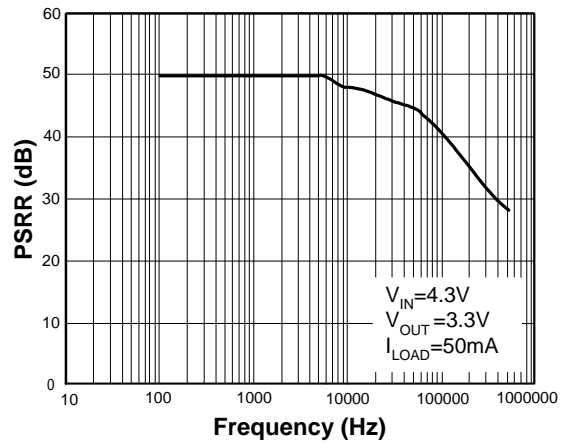
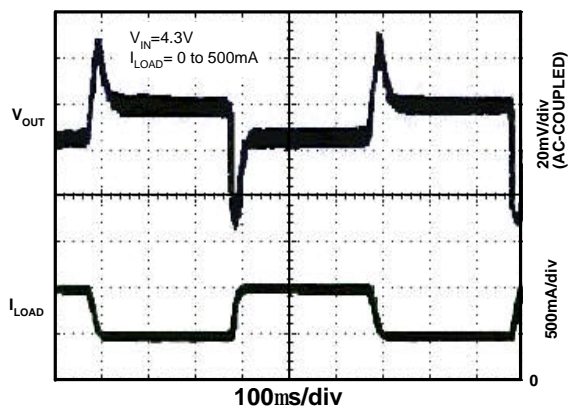
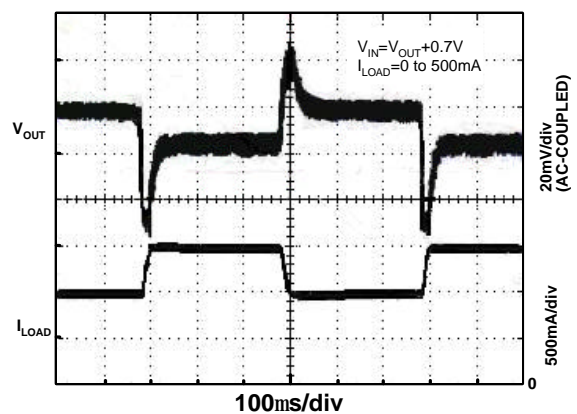
**Dropout Voltage vs Output Voltage**

**Output Voltage vs Temperature**

**Supply Current vs Load Current**

**PSRR vs Frequency**

**Load Transient**

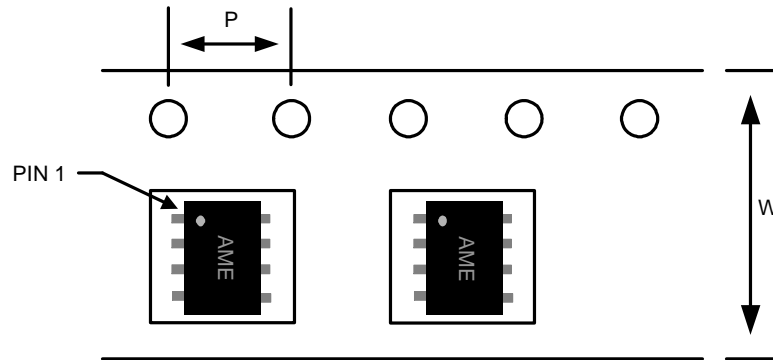
**Load Transient Near Dropout**





■ Tape and Reel Dimension

SOP-8/PP



Carrier Tape, Number of Components Per Reel and Reel Size

Package	Carrier Width (W)	Pitch (P)	Part Per Full Reel	Reel Size
SOP-8/PP	12.0±0.1 mm	4.0±0.1 mm	2500pcs	330±1 mm

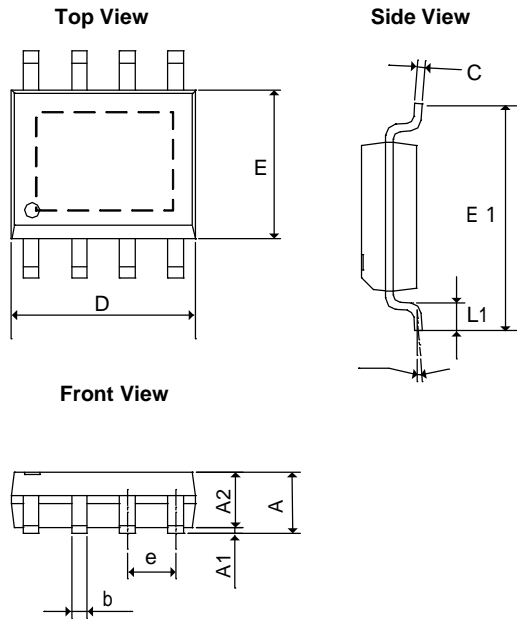
**■ Package Dimension**
**SOP-8/PP**

SYMBOLS	MILLIMETERS		INCHES	
	MIN	MAX	MIN	MAX
<b>A</b>	-	1.700	-	0.067
<b>A<sub>1</sub></b>	0.050	0.150	0.002	0.006
<b>A<sub>2</sub></b>	1.350	1.550	0.053	0.061
<b>C</b>	0.100	0.250	0.004	0.010
<b>E</b>	3.750	4.150	0.148	0.163
<b>E1</b>	5.700	6.300	0.224	0.248
<b>L</b>	0.300	0.700	0.012	0.028
<b>b</b>	0.310	0.510	0.012	0.020
<b>D</b>	4.720	5.120	0.186	0.202
<b>e</b>	1.270 BSC		0.05 BSC	
<b>q</b>	0°	8°	0°	8°



**www.ame.com.tw**  
**E-Mail: sales@ame.com.tw**

**Life Support Policy:**

These products of AME, Inc. are not authorized for use as critical components in life-support devices or systems, without the express written approval of the president of AME, Inc.

AME, Inc. reserves the right to make changes in the circuitry and specifications of its devices and advises its customers to obtain the latest version of relevant information.

© AME, Inc. , February 2007

Document: 2075-DS8753-A.02

**Corporate Headquarter**  
**AME, Inc.**

2F, 302 Rui-Guang Road, Nei-Hu District  
Taipei 114, Taiwan.  
Tel: 886 2 2627-8687  
Fax: 886 2 2659-2989

**U.S.A. (Subsidiary)**  
**Analog Microelectronics, Inc.**

3100 De La Cruz Blvd., Suite 201  
Santa Clara, CA. 95054-2438  
Tel : (408) 988-2388  
Fax: (408) 988-2489