



## 16Mbit Low Voltage, Serial Flash Memory With 100MHz Uniform 4KB Sectors

---

### Document Title

16Mbit, Low Voltage, Serial Flash Memory With 100MHz Uniform 4KB Sectors

### Revision History

<u>Rev. No.</u>	<u>History</u>	<u>Issue Date</u>	<u>Remark</u>
1.0	Initial issue	April 2, 2008	Final
1.1	Add the spec. of I <sub>CC3</sub> for 100MHz Modify the I <sub>CC1</sub> and I <sub>CC2</sub> to 25 $\mu$ A Modify the I <sub>CC7</sub> to 25mA Modify the t <sub>PP</sub> to 3ms Modify the t <sub>SE</sub> to 0.2s	December 26, 2008	
1.2	Modify the Sector Erase Time to 0.2s (typical) Modify the Page Program Time to 2ms (typical) Modify the Active Read Current to 35mA (Max.) Modify the Program/Erase Current to 25mA (Max.) Modify the Standby Current to 25 $\mu$ A (Max.) Modify Block Erase Cycle Time to 1.3s (Max.) Modify Chip Erase Cycle Time to 40s (Max.)	April 9, 2009	
1.3	Add packing description in Part Numbering Scheme	April 23, 2010	
1.4	P30: Change Data Retention and Endurance value from Max. to Min.	October 27, 2010	
1.5	Add 8-pin WSON (6*5mm) package type	December 21, 2010	
1.6	Change t <sub>w</sub> , t <sub>SE</sub> , t <sub>BE</sub> and t <sub>CE</sub> values	August 19, 2011	
1.7	P1: Add "Provide 64Bytes Security ID (application note is available by request)" in Features	September 20, 2011	
1.8	Add 8-pin SOP (150mil) package type	October 11, 2011	
1.9	Change t <sub>SE</sub> (typ.) from 0.15s to 0.08s Change t <sub>SE</sub> (max.) from 0.28s to 0.2s Change t <sub>BE</sub> (typ.) from 0.7s to 0.5s	November 15, 2011	
2.0	P31: Change I <sub>CC6</sub> (max.) from 15mA to 25mA	March 29, 2012	



# A25L016 Series

## 16Mbit Low Voltage, Serial Flash Memory With 100MHz Uniform 4KB Sectors

### FEATURES

- Family of Serial Flash Memories
  - A25L016: 16M-bit /2M-byte
- Flexible Sector Architecture with 4KB sectors
  - Sector Erase (4K-bytes) in 80ms (typical)
  - Block Erase (64K-bytes) in 500ms (typical)
- Page Program (up to 256 Bytes) in 2ms (typical)
- 2.7 to 3.6V Single Supply Voltage
- Dual input / output instructions resulting in an equivalent clock frequency of 200MHz:
  - Dual Output Fast Read Instruction
  - Dual Input and Output Fast Read Instruction
- SPI Bus Compatible Serial Interface
- 100MHz Clock Rate (maximum)
- 16Mbit Flash memory
  - Uniform 4-Kbyte sectors
  - Uniform 64-Kbyte blocks
- Electronic Signatures
  - JEDEC Standard Two-Byte Signature  
A25L016: (3015h)
  - RES Instruction, One-Byte, Signature, for backward compatibility  
A25L016 (14h)
- Package options
  - 8-pin SOP (150/209mil), 16-pin SOP (300mil), 8-pin DIP (300mil) or 8-pin WSON (6\*5mm)
  - All Pb-free (Lead-free) products are RoHS compliant
- Provide 64Bytes Security ID (application note is available by request)

### GENERAL DESCRIPTION

The A25L016 is 16M bit Serial Flash Memory, with advanced write protection mechanisms, accessed by a high speed SPI-compatible bus.

The memory can be programmed 1 to 256 bytes at a time, using the Page Program instruction.

The memory is organized as 32 blocks, each containing 16

sectors. Each sector is composed of 16 pages. Each page is 256 bytes wide. Thus, the whole memory can be viewed as consisting of 8,192 pages, or 2,097,152 bytes.

The whole memory can be erased using the Chip Erase instruction, a block at a time, using Block Erase instruction, or a sector at a time, using the Sector Erase instruction.

### Pin Configurations

#### ■ SOP8 Connections

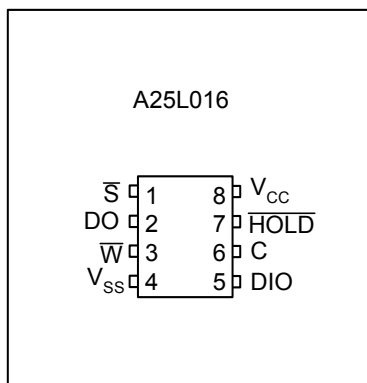

#### ■ SOP16 Connections

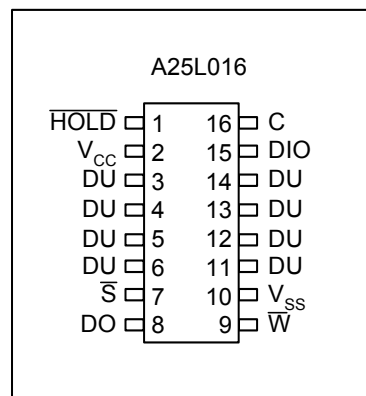

Note:

DU = Do not Use

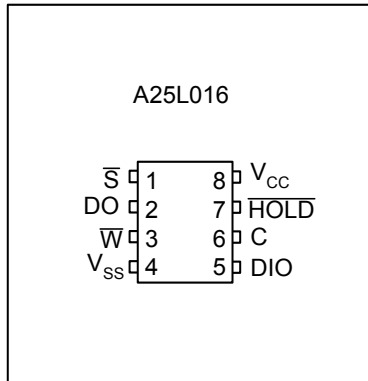
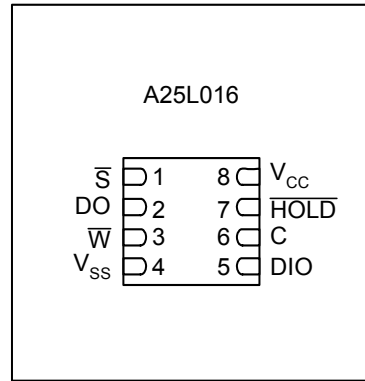
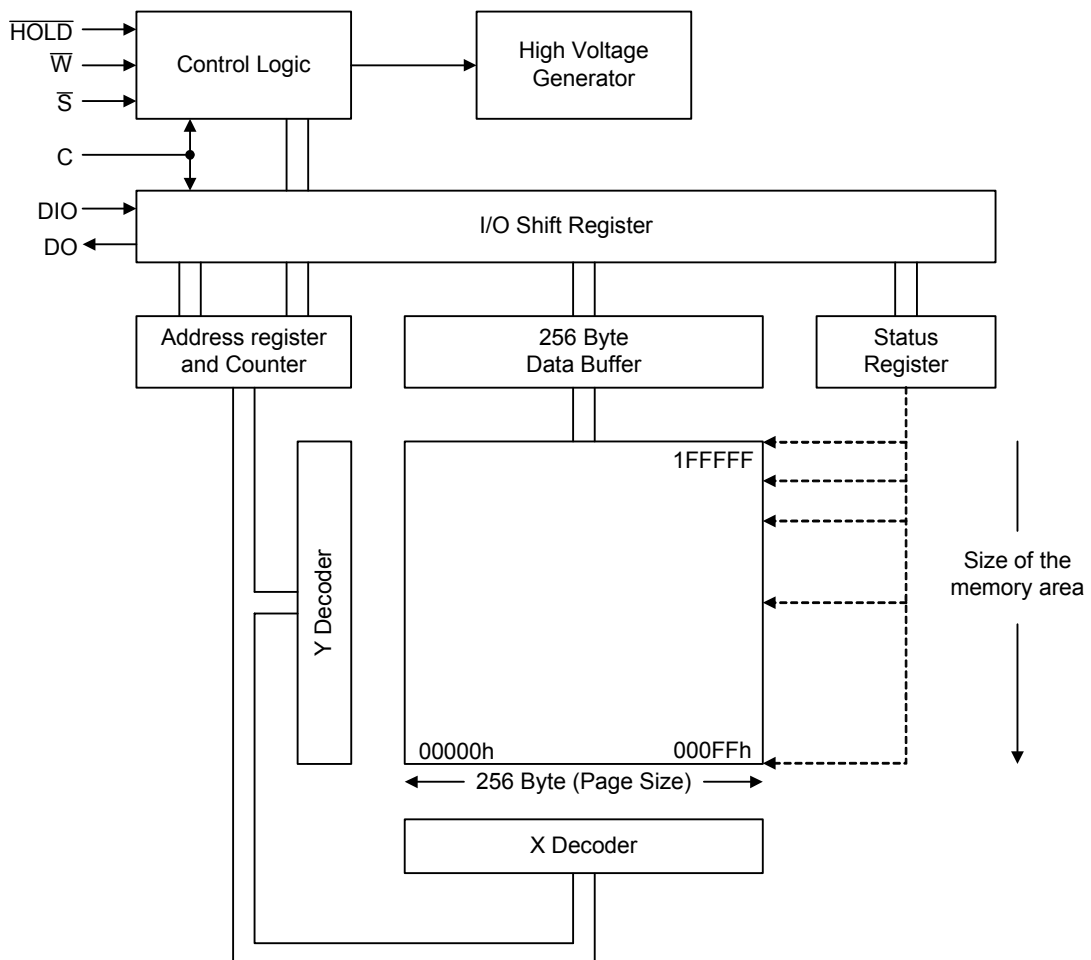
**Pin Configurations (Continued)**
**■ DIP8 Connections**

**■ WSON8 Connections**

**Block Diagram**

**Pin Descriptions**

Pin No.	Description
C	Serial Clock
DIO	Serial Data Input <sup>1</sup>
DO	Serial Data Output <sup>2</sup>
$\bar{S}$	Chip Select
$\bar{W}$	Write Protect
$\bar{HOLD}$	Hold
Vcc	Supply Voltage
Vss	Ground

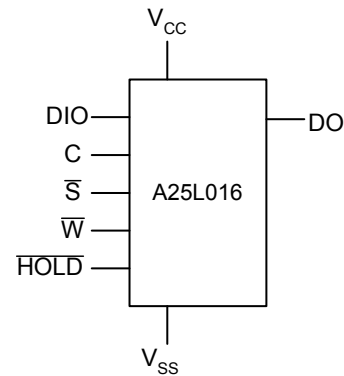
**Notes:**

1. The DIO is also used as an output pin when the Fast Read Dual Output instruction and the Fast Read Dual Input-Output instruction are executed.
2. The DO is also used as an input pin when the Fast Read Dual Input-Output instruction.

**Logic Symbol**

**SIGNAL DESCRIPTION**

**Serial Data Output (DO).** This output signal is used to transfer data serially out of the device. Data is shifted out on the falling edge of Serial Clock (C).

The DO pin is also used as an input pin when the Fast Read Dual Input-Output instruction and Dual Input Fast Program is executed.

**Serial Data Input (DIO).** This input signal is used to transfer data serially into the device. It receives instructions, addresses, and the data to be programmed. Values are latched on the rising edge of Serial Clock (C).

The DIO pin is also used as an output pin when the Fast Read Dual Output instruction and the Fast Read Dual Input-Output instruction are executed.

**Serial Clock (C).** This input signal provides the timing of the serial interface. Instructions, addresses, or data present at Serial Data Input (DIO) are latched on the rising edge of Serial Clock (C). Data on Serial Data Output (DO) changes after the falling edge of Serial Clock (C).

**Chip Select ( $\bar{S}$ ).** When this input signal is High, the device is deselected and Serial Data Output (DO) is at high impedance. Unless an internal Program, Erase or Write

Status Register cycle is in progress, the device will be in the Standby mode (this is not the Deep Power-down mode). Driving Chip Select ( $\bar{S}$ ) Low enables the device, placing it in the active power mode.

After Power-up, a falling edge on Chip Select ( $\bar{S}$ ) is required prior to the start of any instruction.

**Hold ( $\bar{HOLD}$ ).** The Hold ( $\bar{HOLD}$ ) signal is used to pause any serial communications with the device without deselecting the device.

During the Hold condition, the Serial Data Output (DO) is high impedance, and Serial Data Input (DIO) and Serial Clock (C) are Don't Care. To start the Hold condition, the device must be selected, with Chip Select ( $\bar{S}$ ) driven Low.

**Write Protect ( $\bar{W}$ ).** The main purpose of this input signal is to freeze the size of the area of memory that is protected against program or erase instructions (as specified by the values in the BP2, BP1, and BP0 bits of the Status Register).

**SPI MODES**

These devices can be driven by a microcontroller with its SPI peripheral running in either of the two following modes:

- CPOL=0, CPHA=0
- CPOL=1, CPHA=1

For these two modes, input data is latched in on the rising edge of Serial Clock (C), and output data is available from the

falling edge of Serial Clock (C).

The difference between the two modes, as shown in Figure 2, is the clock polarity when the bus master is in Stand-by mode and not transferring data:

- C remains at 0 for (CPOL=0, CPHA=0)
- C remains at 1 for (CPOL=1, CPHA=1)

**Figure 1. Bus Master and Memory Devices on the SPI Bus**

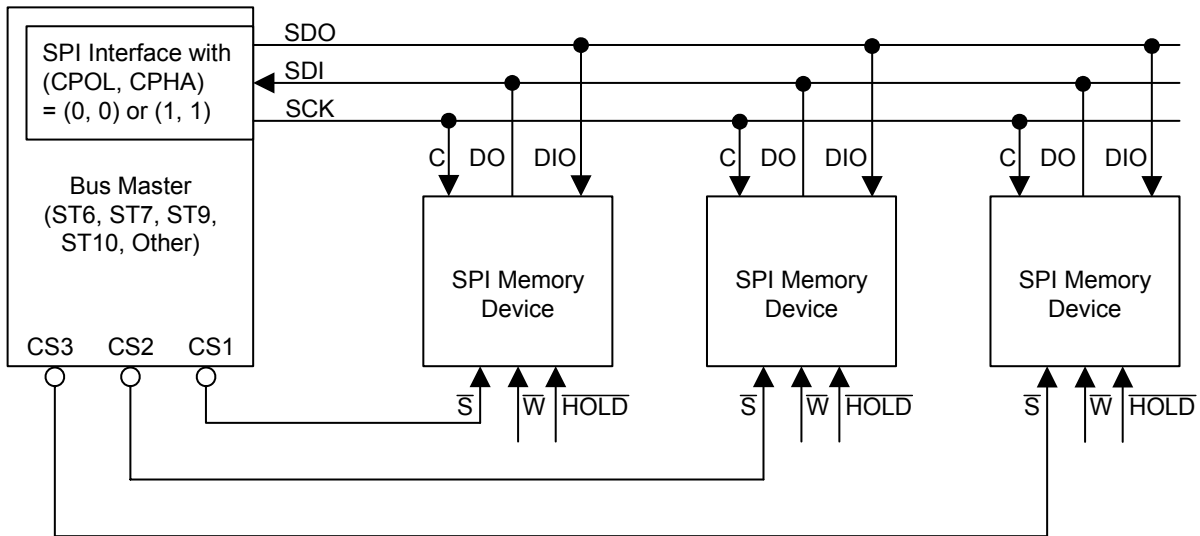

Note: The Write Protect ( $\overline{W}$ ) and Hold ( $\overline{HOLD}$ ) signals should be driven, High or Low as appropriate.

**Figure 2. SPI Modes Supported**

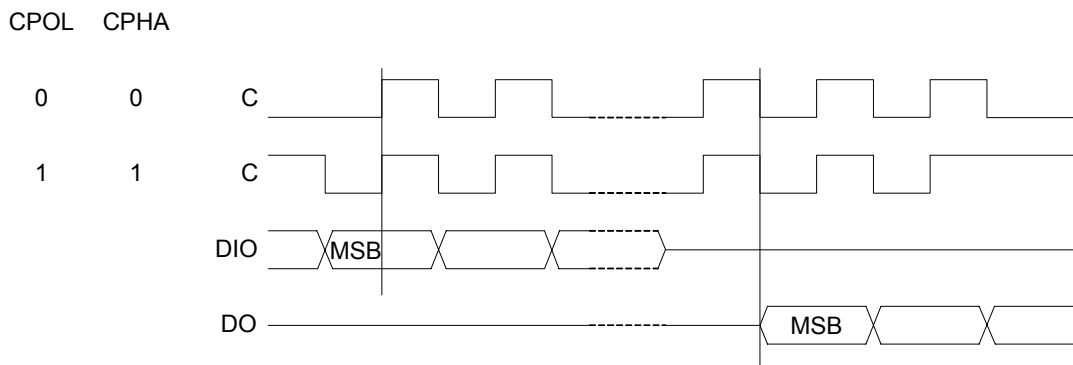

## OPERATING FEATURES

### Page Programming

To program one data byte, two instructions are required: Write Enable (WREN), which is one byte, and a Page Program (PP) sequence, which consists of four bytes plus data. This is followed by the internal Program cycle (of duration  $t_{PP}$ ).

To spread this overhead, the Page Program (PP) instruction allows up to 256 bytes to be programmed at a time (changing bits from 1 to 0), provided that they lie in consecutive addresses on the same page of memory.

### Sector Erase, Block Erase, and Chip Erase

The Page Program (PP) instruction and Dual Input Fast Program (DIFP) instruction allow bits to be reset from 1 to 0. Before this can be applied, the bytes of memory need to have been erased to all 1s (FFh). This can be achieved, a sector at a time, using the Sector Erase (SE) instruction, a block at a time, using the Block Erase (BE) instruction, or throughout the entire memory, using the Chip Erase (CE) instruction. This starts an internal Erase cycle (of duration  $t_{SE}$ ,  $t_{BE}$ , or  $t_{CE}$ ).

The Erase instruction must be preceded by a Write Enable (WREN) instruction.

### Polling During a Write, Program or Erase Cycle

A further improvement in the time to Write Status Register (WRSR), Program (PP) or Erase (SE, BE, or CE) can be achieved by not waiting for the worst case delay ( $t_w$ ,  $t_{PP}$ ,  $t_{SE}$ ,  $t_{BE}$ ,  $t_{CE}$ ). The Write In Progress (WIP) bit is provided in the Status Register so that the application program can monitor its value, polling it to establish when the previous Write cycle, Program cycle or Erase cycle is complete.

### Active Power, Stand-by Power and Deep Power-Down Modes

When Chip Select ( $\bar{S}$ ) is Low, the device is enabled, and in the Active Power mode.

When Chip Select ( $\bar{S}$ ) is High, the device is disabled, but could remain in the Active Power mode until all internal cycles have completed (Program, Erase, Write Status Register). The device then goes in to the Stand-by Power mode. The device consumption drops to  $I_{cc1}$ .

The Deep Power-down mode is entered when the specific instruction (the Deep Power-down Mode (DP) instruction) is executed. The device consumption drops further to  $I_{cc2}$ . The device remains in this mode until another specific instruction (the Release from Deep Power-down Mode and Read Electronic Signature (RES) instruction) is executed.

All other instructions are ignored while the device is in the Deep Power-down mode. This can be used as an extra software protection mechanism, when the device is not in active use, to protect the device from inadvertent Write, Program or Erase instructions.

### Status Register

The Status Register contains a number of status and control bits that can be read or set (as appropriate) by specific instructions.

**WIP bit.** The Write In Progress (WIP) bit indicates whether the memory is busy with a Write Status Register, Program or Erase cycle.

**WEL bit.** The Write Enable Latch (WEL) bit indicates the status of the internal Write Enable Latch.

**BP2, BP1, BP0 bits.** The Block Protect (BP2, BP1, BP0) bits are non-volatile. They define the size of the area to be software protected against Program and Erase instructions.

**SRWD bit.** The Status Register Write Disable (SRWD) bit is operated in conjunction with the Write Protect ( $\bar{W}$ ) signal. The Status Register Write Disable (SRWD) bit and Write Protect ( $\bar{W}$ ) signal allow the device to be put in the Hardware Protected mode. In this mode, the non-volatile bits of the Status Register (SRWD, BP2, BP1, BP0) become read-only bits.

### Protection Modes

The environments where non-volatile memory devices are used can be very noisy. No SPI device can operate correctly in the presence of excessive noise. To help combat this, the A25L016 boasts the following data protection mechanisms:

- Power-On Reset and an internal timer ( $t_{PUW}$ ) can provide protection against inadvertent changes while the power supply is outside the operating specification.
- Program, Erase and Write Status Register instructions are checked that they consist of a number of clock pulses that is a multiple of eight, before they are accepted for execution.
- All instructions that modify data must be preceded by a Write Enable (WREN) instruction to set the Write Enable Latch (WEL) bit. This bit is returned to its reset state by the following events:
  - Power-up
  - Write Disable (WRDI) instruction completion
  - Write Status Register (WRSR) instruction completion
  - Page Program (PP) instruction completion
  - Sector Erase (SE) instruction completion
  - Block Erase (BE) instruction completion
  - Chip Erase (CE) instruction completion
- The Block Protect (BP2, BP1, BP0) bits allow part of the memory to be configured as read-only. This is the Software Protected Mode (SPM).
- The Write Protect ( $\bar{W}$ ) signal allows the Block Protect (BP2, BP1, BP0) bits and Status Register Write Disable (SRWD) bit to be protected. This is the Hardware Protected Mode (HPM).
- In addition to the low power consumption feature, the Deep Power-down mode offers extra software protection from inadvertent Write, Program and Erase instructions, as all instructions are ignored except one particular instruction (the Release from Deep Power-down instruction).

**Table 1. Protected Area Sizes**

Status Register Content			Memory Protection			
BP2	BP1	BP0	Block(s)	Addresses	Density	Portion
0	0	0	None	None	None	None
0	0	1	31	1F0000h – 1FFFFFFh	64KB	Upper 1/32
0	1	0	30 – 31	1E0000h – 1FFFFFFh	128KB	Upper 1/16
0	1	1	28 – 31	1C0000h – 1FFFFFFh	256KB	Upper 1/8
1	0	0	24 – 31	180000h – 1FFFFFFh	512KB	Upper 1/4
1	0	1	16 – 31	100000h – 1FFFFFFh	1MB	Upper 1/2
1	1	X	0 – 31	000000h – 1FFFFFFh	2MB	All

Note:

1. X = don't care
2. The device is ready to accept a Chip Erase instruction if, and only if, all Block Protect (BP2, BP1, BP0) are 0.

### Hold Condition

The Hold ( $\overline{\text{HOLD}}$ ) signal is used to pause any serial communications with the device without resetting the clocking sequence. However, taking this signal Low does not terminate any Write Status Register, Program or Erase cycle that is currently in progress.

To enter the Hold condition, the device must be selected, with Chip Select ( $\overline{\text{S}}$ ) Low.

The Hold condition starts on the falling edge of the Hold ( $\overline{\text{HOLD}}$ ) signal, provided that this coincides with Serial Clock (C) being Low (as shown in Figure 3.).

The Hold condition ends on the rising edge of the Hold ( $\overline{\text{HOLD}}$ ) signal, provided that this coincides with Serial Clock (C) being Low.

If the falling edge does not coincide with Serial Clock (C) being Low, the Hold condition starts after Serial Clock (C) next goes Low. Similarly, if the rising edge does not coincide with Serial Clock (C) being Low, the Hold condition ends after

Serial Clock (C) next goes Low. This is shown in Figure 3. During the Hold condition, the Serial Data Output (DO) is high impedance, and Serial Data Input (DIO) and Serial Clock (C) are Don't Care.

Normally, the device is kept selected, with Chip Select ( $\overline{\text{S}}$ ) driven Low, for the whole duration of the Hold condition. This is to ensure that the state of the internal logic remains unchanged from the moment of entering the Hold condition.

If Chip Select ( $\overline{\text{S}}$ ) goes High while the device is in the Hold condition, this has the effect of resetting the internal logic of the device. To restart communication with the device, it is necessary to drive Hold ( $\overline{\text{HOLD}}$ ) High, and then to drive Chip Select ( $\overline{\text{S}}$ ) Low. This prevents the device from going back to the Hold condition.

**Figure 3. Hold Condition Activation**

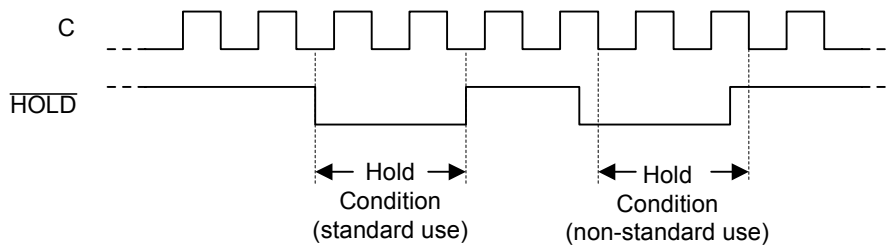



**MEMORY ORGANIZATION**

The memory is organized as:

- 2,097,152 bytes (8 bits each)
- 32 blocks (64 Kbytes each)
- 512 sectors (4 Kbytes each)
- 8192 pages (256 bytes each)

Each page can be individually programmed (bits are programmed from 1 to 0). The device is Sector, Block, or Chip Erasable (bits are erased from 0 to 1) but not Page Erasable.

**Table 2. Memory Organization**
**A25L016 Address Table**

Block	Sector	Address range	
31	511	1FF000h	1FFFFFFh
	⋮	⋮	⋮
30	496	1F0000h	1F0FFFh
	495	1EF000h	1EFFFFh
29	479	1DF000h	1DFFFFh
	464	1D0000h	1D0FFFh
28	463	1CF000h	1CFFFFh
	448	1C0000h	1C0FFFh
27	447	1BF000h	1BFFFFh
	432	1B0000h	1B0FFFh
26	431	1AF000h	1AFFFFh
	416	1A0000h	1A0FFFh
25	415	19F000h	19FFFFh
	400	190000h	190FFFh
24	399	18F000h	18FFFFh
	384	180000h	180FFFh
23	383	17F000h	17FFFFh
	368	170000h	170FFFh
22	367	16F000h	16FFFFh
	352	160000h	160FFFh
21	351	15F000h	15FFFFh
	336	150000h	150FFFh

Block	Sector	Address range	
20	335	14F000h	14FFFFh
	320	140000h	140FFFh
19	319	13F000h	13FFFFh
	304	130000h	130FFFh
18	303	12F000h	12FFFFh
	288	120000h	120FFFh
17	287	11F000h	11FFFFh
	272	110000h	110FFFh
16	271	10F000h	10FFFFh
	256	100000h	100FFFh
15	255	FF000h	FFFFFFh
	240	F0000h	F0FFFh
14	239	EF000h	EFFFFh
	224	E0000h	E0FFFh
13	223	DF000h	DFFFFh
	208	D0000h	D0FFFh
12	207	CF000h	CFFFFh
	192	C0000h	C0FFFh
11	191	BF000h	BFFFFh
	176	B0000h	B0FFFh
10	175	AF000h	AFFFFh
	160	A0000h	A0FFFh

**Memory Organization (continued)**

Block	Sector	Address range	
9	159	9F000h	9FFFFh
	⋮	⋮	⋮
	144	90000h	90FFFh
8	143	8F000h	8FFFFh
	⋮	⋮	⋮
	128	80000h	80FFFh
7	127	7F000h	7FFFFh
	⋮	⋮	⋮
	112	70000h	70FFFh
6	111	6F000h	6FFFFh
	⋮	⋮	⋮
	96	60000h	60FFFh
5	95	5F000h	5FFFFh
	⋮	⋮	⋮
	80	50000h	50FFFh
4	79	4F000h	4FFFFh
	⋮	⋮	⋮
	64	40000h	40FFFh

Block	Sector	Address range	
3	63	3F000h	3FFFFh
	⋮	⋮	⋮
	48	30000h	30FFFh
2	47	2F000h	2FFFFh
	⋮	⋮	⋮
	32	20000h	20FFFh
1	31	1F000h	1FFFFh
	⋮	⋮	⋮
	16	10000h	10FFFh
0	15	0F000h	0FFFFh
	⋮	⋮	⋮
	4	04000h	04FFFh
	3	03000h	03FFFh
	2	02000h	02FFFh
	1	01000h	01FFFh
	0	00000h	00FFFh

**INSTRUCTIONS**

All instructions, addresses and data are shifted in and out of the device, most significant bit first.

Serial Data Input (DIO) is sampled on the first rising edge of Serial Clock (C) after Chip Select ( $\bar{S}$ ) is driven Low. Then, the one-byte instruction code must be shifted in to the device, most significant bit first, on Serial Data Input (DIO), each bit being latched on the rising edges of Serial Clock (C).

The instruction set is listed in Table 3.

Every instruction sequence starts with a one-byte instruction code. Depending on the instruction, this might be followed by address bytes, or by data bytes, or by both or none.

In the case of a Read Data Bytes (READ), Read Data Bytes at Higher Speed (Fast\_Read), Read Identification (RDID), Read Electronic Manufacturer and Device Identification (REMS), Read Status Register (RDSR) or Release from Deep Power-down, Read Device Identification and Read Electronic Signature (RES) instruction, the shifted-in instruction sequence is followed by a data-out sequence. Chip Select ( $\bar{S}$ )

can be driven High after any bit of the data-out sequence is being shifted out.

In the case of a Page Program (PP), Sector Erase (SE), Block Erase (BE), Chip Erase (CE), Write Status Register (WRSR), Write Enable (WREN), Write Disable (WRDI) or Deep Power-down (DP) instruction, Chip Select ( $\bar{S}$ ) must be driven High exactly at a byte boundary, otherwise the instruction is rejected, and is not executed. That is, Chip Select ( $\bar{S}$ ) must be driven High when the number of clock pulses after Chip Select ( $\bar{S}$ ) being driven Low is an exact multiple of eight.

All attempts to access the memory array during a Write Status Register cycle, Program cycle or Erase cycle are ignored, and the internal Write Status Register cycle, Program cycle or Erase cycle continues unaffected.

**Table 3. Instruction Set**

Instruction	Description	One-byte Instruction Code		Address Bytes	Dummy Bytes	Data Bytes
		Code	Hex			
WREN	Write Enable	0000 0110	06h	0	0	0
WRDI	Write Disable	0000 0100	04h	0	0	0
RDSR	Read Status Register	0000 0101	05h	0	0	1 to ∞
WRSR	Write Status Register	0000 0001	01h	0	0	1
READ	Read Data Bytes	0000 0011	03h	3	0	1 to ∞
FAST_READ	Read Data Bytes at Higher Speed	0000 1011	0Bh	3	1	1 to ∞
FAST_READ_DUAL_OUTPUT	Read Data Bytes at Higher Speed by Dual Output <sup>(1)</sup>	00111011	3Bh	3	1	1 to ∞
FAST_READ_DUAL_INPUT-OUTPUT	Read Data Bytes at Higher Speed by Dual Input and Dual Output <sup>(1)</sup>	10111011	BBh	3 <sup>(2)</sup>	1 <sup>(2)</sup>	1 to ∞
PP	Page Program	0000 0010	02h	3	0	1 to 256
SE	Sector Erase	0010 0000	20h	3	0	0
BE	Block Erase	1101 1000	D8h	3	0	0
CE	Chip Erase	1100 0111	C7h	0	0	0
DP	Deep Power-down	1011 1001	B9h	0	0	0
RDID	Read Device Identification	1001 1111	9Fh	0	0	1 to ∞
REMS	Read Electronic Manufacturer & Device Identification	1001 0000	90h	1 <sup>(3)</sup>	2	1 to ∞
RES	Release from Deep Power-down, and Read Electronic Signature	1010 1011	ABh	0	3	1 to ∞
	Release from Deep Power-down			0	0	0

Note: (1) DIO = (D<sub>6</sub>, D<sub>4</sub>, D<sub>2</sub>, D<sub>0</sub>)  
DO = (D<sub>7</sub>, D<sub>5</sub>, D<sub>3</sub>, D<sub>1</sub>)

(2) Dual Input, DIO = (A<sub>22</sub>, A<sub>20</sub>, A<sub>18</sub>, ....., A<sub>6</sub>, A<sub>4</sub>, A<sub>2</sub>, A<sub>0</sub>)  
DO = (A<sub>23</sub>, A<sub>21</sub>, A<sub>19</sub>, ....., A<sub>7</sub>, A<sub>5</sub>, A<sub>3</sub>, A<sub>1</sub>)

(3) ADD=(00h) will output manufacturer's ID first and ADD=(01h) will output device ID first

### Write Enable (WREN)

The Write Enable (WREN) instruction (Figure 4.) sets the Write Enable Latch (WEL) bit.

The Write Enable Latch (WEL) bit must be set prior to every Page Program (PP), Sector Erase (SE), Block Erase (BE), Chip Erase (CE) and Write Status Register (WRSR)

instruction.

The Write Enable (WREN) instruction is entered by driving Chip Select ( $\bar{S}$ ) Low, sending the instruction code, and then driving Chip Select ( $\bar{S}$ ) High.

**Figure 4. Write Enable (WREN) Instruction Sequence**

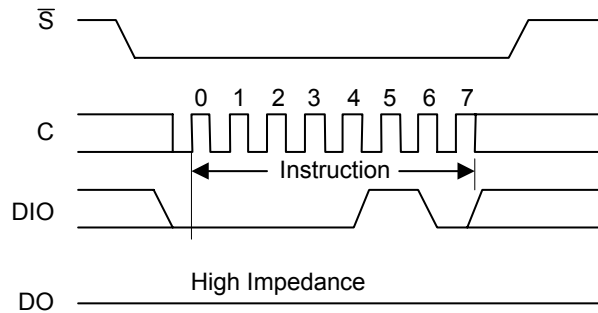

### Write Disable (WRDI)

The Write Disable (WRDI) instruction (Figure 5.) resets the Write Enable Latch (WEL) bit.

The Write Disable (WRDI) instruction is entered by driving Chip Select ( $\bar{S}$ ) Low, sending the instruction code, and then driving Chip The Write Enable Latch (WEL) bit is reset under the following conditions:

- Power-up
- Write Disable (WRDI) instruction completion
- Write Status Register (WRSR) instruction completion
- Page Program (PP) instruction completion
- Sector Erase (SE) instruction completion
- Block Erase (BE) instruction completion
- Chip Erase (CE) instruction completion

**Figure 5. Write Disable (WRDI) Instruction Sequence**

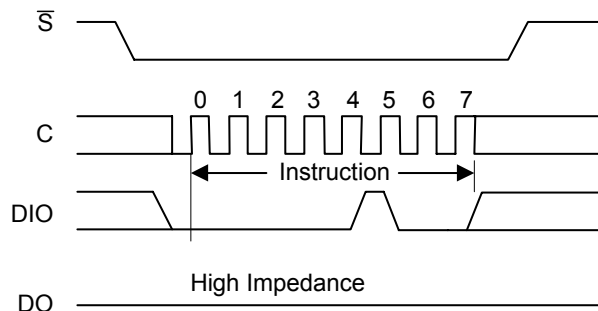

### Read Status Register (RDSR)

The Read Status Register (RDSR) instruction allows the Status Register to be read. The Status Register may be read at any time, even while a Program, Erase or Write Status Register cycle is in progress. When one of these cycles is in progress, it is recommended to check the Write In Progress (WIP) bit before sending a new instruction to the device. It is also possible to read the Status Register continuously, as shown in Figure 6.

**Table 4. Status Register Format**

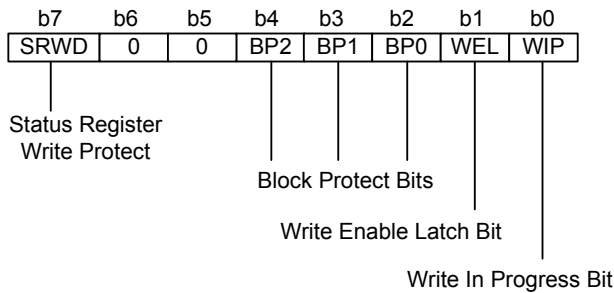

The status and control bits of the Status Register are as follows:

**WIP bit.** The Write In Progress (WIP) bit indicates whether the memory is busy with a Write Status Register, Program or Erase cycle. When set to 1, such a cycle is in progress, when

reset to 0 no such cycle is in progress.

**WEL bit.** The Write Enable Latch (WEL) bit indicates the status of the internal Write Enable Latch. When set to 1 the internal Write Enable Latch is set, when set to 0 the internal Write Enable Latch is reset and no Write Status Register, Program or Erase instruction is accepted.

**BP2, BP1, BP0 bits.** The Block Protect (BP2, BP1, BP0) bits are non-volatile. They define the size of the area to be software protected against Program and Erase instructions. These bits are written with the Write Status Register (WRSR) instruction. When one or more of the Block Protect (BP2, BP1, BP0) bits is set to 1, the relevant memory area (as defined in Table 1.) becomes protected against Page Program (PP), Sector Erase (SE), and Block Erase (BE) instructions. The Block Protect (BP2, BP1, BP0) bits can be written provided that the Hardware Protected mode has not been set. The Chip Erase (CE) instruction is executed if, and only if, all Block Protect (BP2, BP1, BP0) bits are 0.

**SRWD bit.** The Status Register Write Disable (SRWD) bit is operated in conjunction with the Write Protect ( $\overline{W}$ ) signal. The Status Register Write Disable (SRWD) bit and Write Protect ( $\overline{W}$ ) signal allow the device to be put in the Hardware Protected mode (when the Status Register Write Disable (SRWD) bit is set to 1, and Write Protect ( $\overline{W}$ ) is driven Low). In this mode, the non-volatile bits of the Status Register (SRWD, BP2, BP1, BP0) become read-only bits and the Write Status Register (WRSR) instruction is no longer accepted for execution.

**Figure 6. Read Status Register (RDSR) Instruction Sequence and Data-Out Sequence**

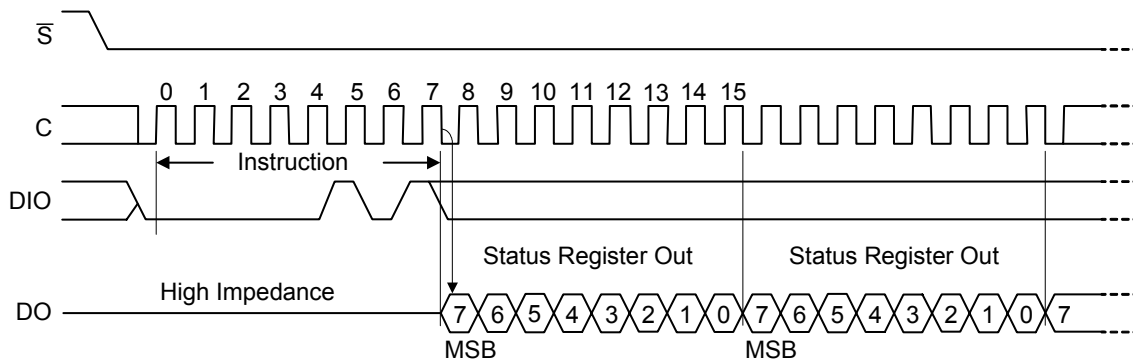

### Write Status Register (WRSR)

The Write Status Register (WRSR) instruction allows new values to be written to the Status Register. Before it can be accepted, a Write Enable (WREN) instruction must previously have been executed. After the Write Enable (WREN) instruction has been decoded and executed, the device sets the Write Enable Latch (WEL).

The Write Status Register (WRSR) instruction is entered by driving Chip Select ( $\overline{S}$ ) Low, followed by the instruction code and the data byte on Serial Data Input (DIO).

The instruction sequence is shown in Figure 7. The Write Status Register (WRSR) instruction has no effect on b6, b5, b1 and b0 of the Status Register. b6 and b5 are always read as 0.

Chip Select ( $\overline{S}$ ) must be driven High after the eighth bit of the data byte has been latched in. If not, the Write Status Register (WRSR) instruction is not executed. As soon as

Chip Select ( $\overline{S}$ ) is driven High, the self-timed Write Status Register cycle (whose duration is  $t_w$ ) is initiated. While the

Write Status Register cycle is in progress, the Status Register may still be read to check the value of the Write In Progress (WIP) bit. The Write In Progress (WIP) bit is 1 during the self-timed Write Status Register cycle, and is 0 when it is completed. When the cycle is completed, the Write Enable Latch (WEL) is reset.

The Write Status Register (WRSR) instruction allows the user to change the values of the Block Protect (BP2, BP1, BP0) bits, to define the size of the area that is to be treated as read-only, as defined in Table 1. The Write Status Register (WRSR) instruction also allows the user to set or reset the Status Register Write Disable (SRWD) bit in accordance with the Write Protect ( $\overline{W}$ ) signal. The Status Register Write Disable (SRWD) bit and Write Protect ( $\overline{W}$ ) signal allow the device to be put in the Hardware Protected Mode (HPM). The Write Status Register (WRSR) instruction is not executed once the Hardware Protected Mode (HPM) is entered.

**Figure 7. Write Status Register (WRSR) Instruction Sequence**

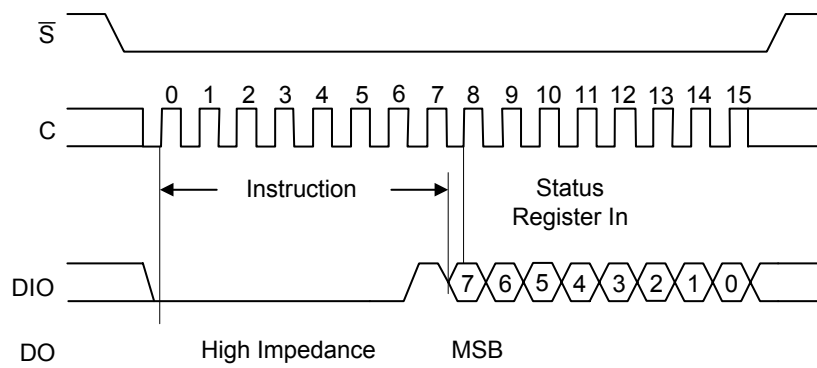

**Table 5. Protection Modes**

$\overline{W}$ Signal	SRWD Bit	Mode	Write Protection of the Status Register	Memory Content	
				Protected Area <sup>1</sup>	Unprotected Area <sup>1</sup>
1	0	Software Protected (SPM)	Status Register is Writable (if the WREN instruction has set the WEL bit). The values in the SRWD, BP2, BP1, and BP0 bits can be changed	Protected against Page Program, Dual Input Fast Program, Sector Erase, Block Erase, and Chip Erase	Ready to accept Page Program, Dual Input Fast Program, Sector Erase, and Block Erase instructions
0	0				
1	1				
0	1	Hardware Protected (HPM)	Status Register is Hardware write protected. The values in the SRWD, BP2, BP1, and BP0 bits cannot be changed	Protected against Page Program, Dual Input Fast Program, Sector Erase, Block Erase, and Chip Erase	Ready to accept Page Program, Dual Input Fast Program, Sector Erase, and Block Erase instructions

Note: 1. As defined by the values in the Block Protect (BP2, BP1, BP0) bits of the Status Register, as shown in Table 1.

The protection features of the device are summarized in Table 5.

When the Status Register Write Disable (SRWD) bit of the Status Register is 0 (its initial delivery state), it is possible to write to the Status Register provided that the Write Enable Latch (WEL) bit has previously been set by a Write Enable (WREN) instruction, regardless of the whether Write Protect ( $\overline{W}$ ) is driven High or Low.

When the Status Register Write Disable (SRWD) bit of the Status Register is set to 1, two cases need to be considered, depending on the state of Write Protect ( $\overline{W}$ ):

- If Write Protect ( $\overline{W}$ ) is driven High, it is possible to write to the Status Register provided that the Write Enable Latch (WEL) bit has previously been set by a Write Enable (WREN) instruction.
- If Write Protect ( $\overline{W}$ ) is driven Low, it is *not* possible to write to the Status Register *even* if the Write Enable Latch (WEL) bit has previously been set by a Write Enable (WREN) instruction. (Attempts to write to the Status

Register are rejected, and are not accepted for execution). As a consequence, all the data bytes in the memory area that are software protected (SPM) by the Block Protect (BP2, BP1, BP0) bits of the Status Register, are also hardware protected against data modification.

Regardless of the order of the two events, the Hardware Protected Mode (HPM) can be entered:

- by setting the Status Register Write Disable (SRWD) bit after driving Write Protect ( $\overline{W}$ ) Low
- or by driving Write Protect ( $\overline{W}$ ) Low after setting the Status Register Write Disable (SRWD) bit.

The only way to exit the Hardware Protected Mode (HPM) once entered is to pull Write Protect ( $\overline{W}$ ) High.

If Write Protect ( $\overline{W}$ ) is permanently tied High, the Hardware Protected Mode (HPM) can never be activated, and only the Software Protected Mode (SPM), using the Block Protect (BP2, BP1, BP0) bits of the Status Register, can be used.

### Read Data Bytes (READ)

The device is first selected by driving Chip Select ( $\bar{S}$ ) Low. The instruction code for the Read Data Bytes (READ) instruction is followed by a 3-byte address (A23-A0), each bit being latched-in during the rising edge of Serial Clock (C). Then the memory contents, at that address, is shifted out on Serial Data Output (DO), each bit being shifted out, at a maximum frequency  $f_R$ , during the falling edge of Serial Clock (C).

The instruction sequence is shown in Figure 8. The first byte addressed can be at any location. The address is automatically incremented to the next higher address after each byte of data is shifted out. The whole memory can,

therefore, be read with a single Read Data Bytes (READ) instruction. When the highest address is reached, the address counter rolls over to 000000h, allowing the read sequence to be continued indefinitely.

The Read Data Bytes (READ) instruction is terminated by driving Chip Select ( $\bar{S}$ ) High. Chip Select ( $\bar{S}$ ) can be driven High at any time during data output. Any Read Data Bytes (READ) instruction, while an Erase, Program or Write cycle is in progress, is rejected without having any effects on the cycle that is in progress.

**Figure 8. Read Data Bytes (READ) Instruction Sequence and Data-Out Sequence**

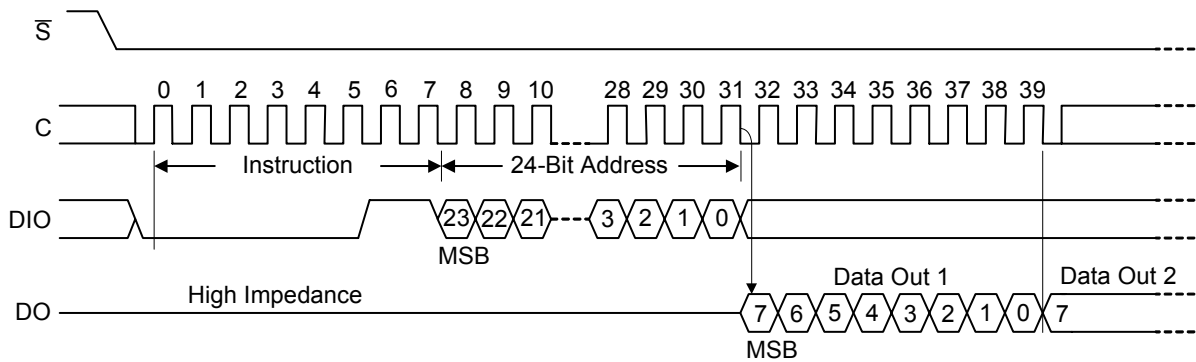

Note: Address bits A23 to A21 are Don't Care, for A25L016.



### Read Data Bytes at Higher Speed (FAST\_READ)

The device is first selected by driving Chip Select ( $\overline{S}$ ) Low. The instruction code for the Read Data Bytes at Higher Speed (FAST\_READ) instruction is followed by a 3-byte address (A23-A0) and a dummy byte, each bit being latched-in during the rising edge of Serial Clock (C). Then the memory contents, at that address, is shifted out on Serial Data Output (DO), each bit being shifted out, at a maximum frequency  $f_c$ , during the falling edge of Serial Clock (C). The instruction sequence is shown in Figure 9. The first byte addressed can be at any location. The address is automatically incremented to the next higher address after each byte of data is shifted out. The whole memory can, therefore, be read with a single Read Data Bytes at Higher

Speed (FAST\_READ) instruction. When the highest address is reached, the address counter rolls over to 000000h, allowing the read sequence to be continued indefinitely. The Read Data Bytes at Higher Speed (FAST\_READ) instruction is terminated by driving Chip Select ( $\overline{S}$ ) High. Chip Select ( $\overline{S}$ ) can be driven High at any time during data output. Any Read Data Bytes at Higher Speed (FAST\_READ) instruction, while an Erase, Program or Write cycle is in progress, is rejected without having any effects on the cycle that is in progress.

**Figure 9. Read Data Bytes at Higher Speed (FAST\_READ) Instruction Sequence and Data-Out Sequence**

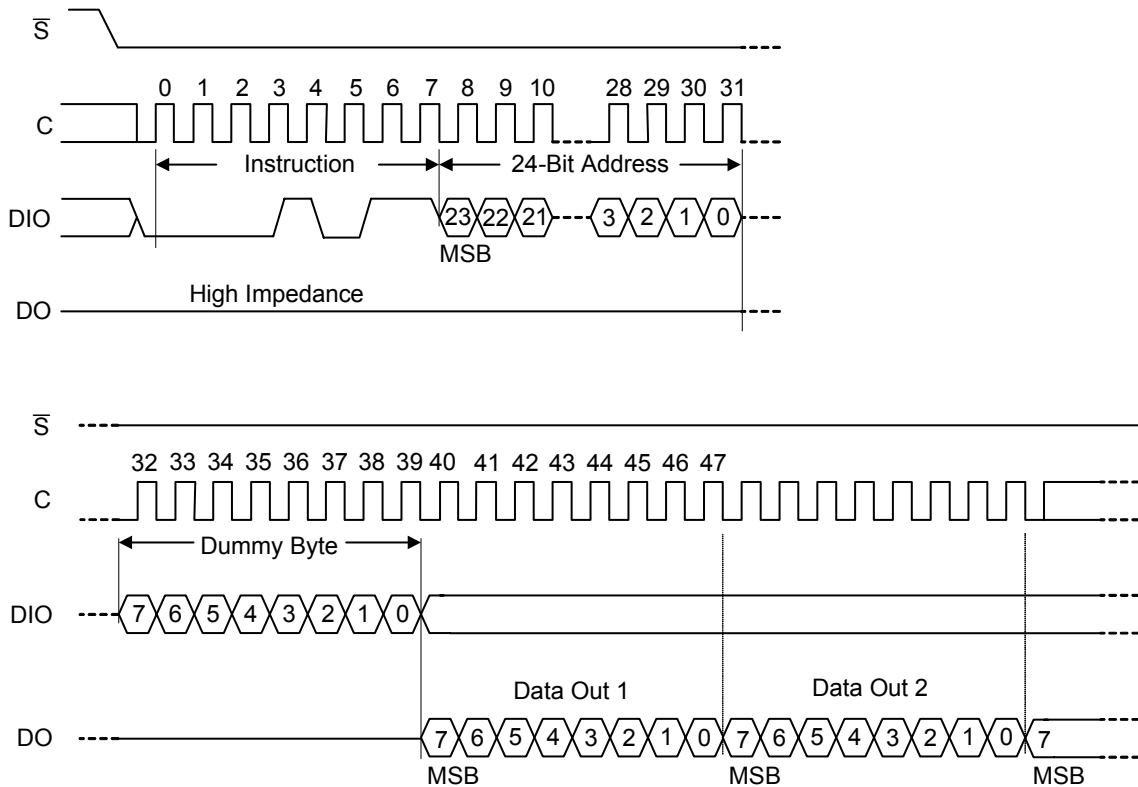

Note:.. Address bits A23 to A21 are Don't Care, for A25L016.

### Fast Read Dual Output (3Bh)

The Fast Read Dual Output (3Bh) instruction is similar to the Fast Read (0Bh) instruction except the data is output on two pins, DO and DIO, instead of just DO. This allows data to be transferred from the A25L016 at twice the rate of standard SPI devices.

Similar to the Fast Read instruction, the Fast Read Dual Output instruction can operate at the highest possible frequency of  $f_c$  (See AC Characteristics). This is

accomplished by adding eight “dummy” clocks after the 24-bit address as shown in figure 10. The dummy clocks allow the device’s internal circuits additional time for setting up the initial address. The input data during the dummy clocks is “don’t care”. However, the DIO pin should be high-impedance prior to the falling edge of the first data out clock.

**Figure 10. FAST\_READ\_DUAL\_OUTPUT Instruction Sequence and Data-Out Sequence**

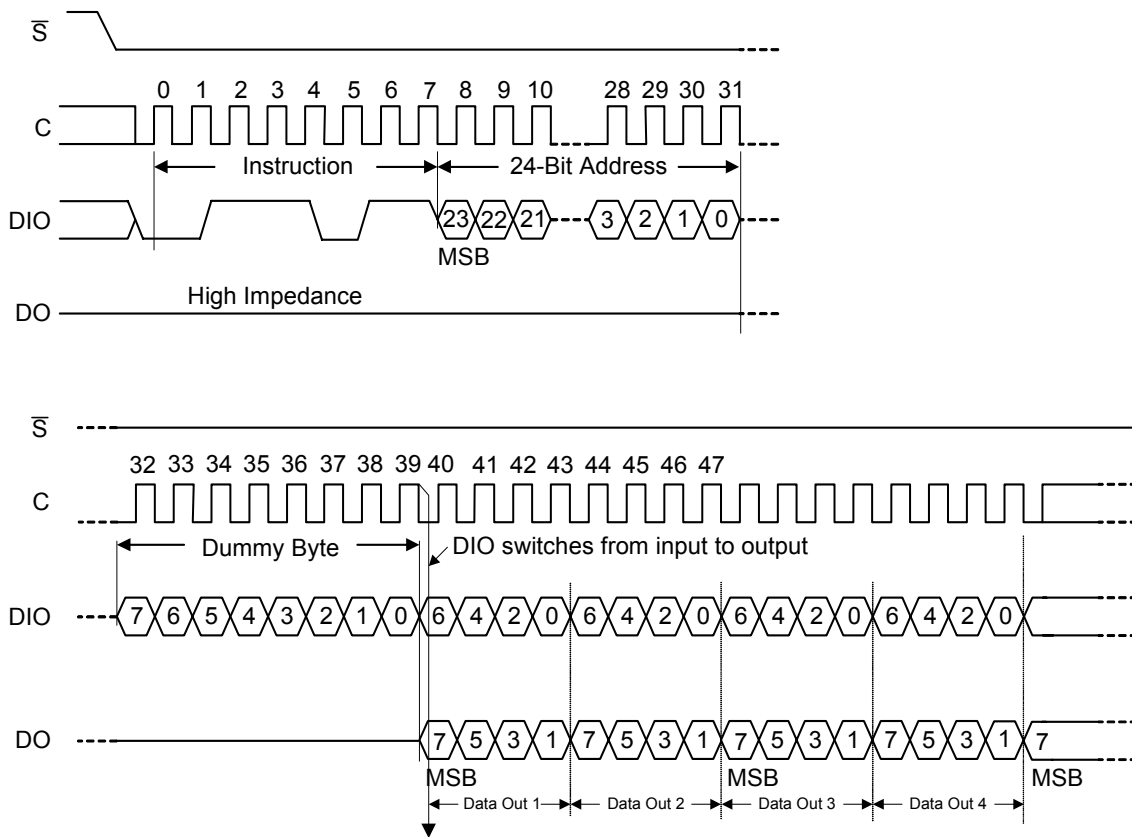

Note: Address bits A23 to A21 are Don't Care, for A25L016.

### Fast Read Dual Input-Output (BBh)

The Fast Read Dual Input-Output (BBh) instruction is similar to the Fast\_Read (0Bh) instruction except the data is input and output on two pins, DIO and DO, instead of just DO. This allows data to be transferred from the A25L016 at twice the rate of standard SPI devices.

Similar to the Fast Read instruction, the Fast Read Dual Output instruction can operate at the highest possible frequency of  $f_c$  (See AC Characteristics). This is

accomplished by adding four “dummy” clocks after the 24-bit address as shown in figure 11. The dummy clocks allow the device’s internal circuits additional time for setting up the initial address. The input data during the dummy clocks is “don’t care”. However, the DIO and DO pins should be high-impedance prior to the falling edge of the first data out clock.

**Figure 11. FAST\_READ\_DUAL\_INPUT-OUTPUT Instruction Sequence and Data-Out Sequence**

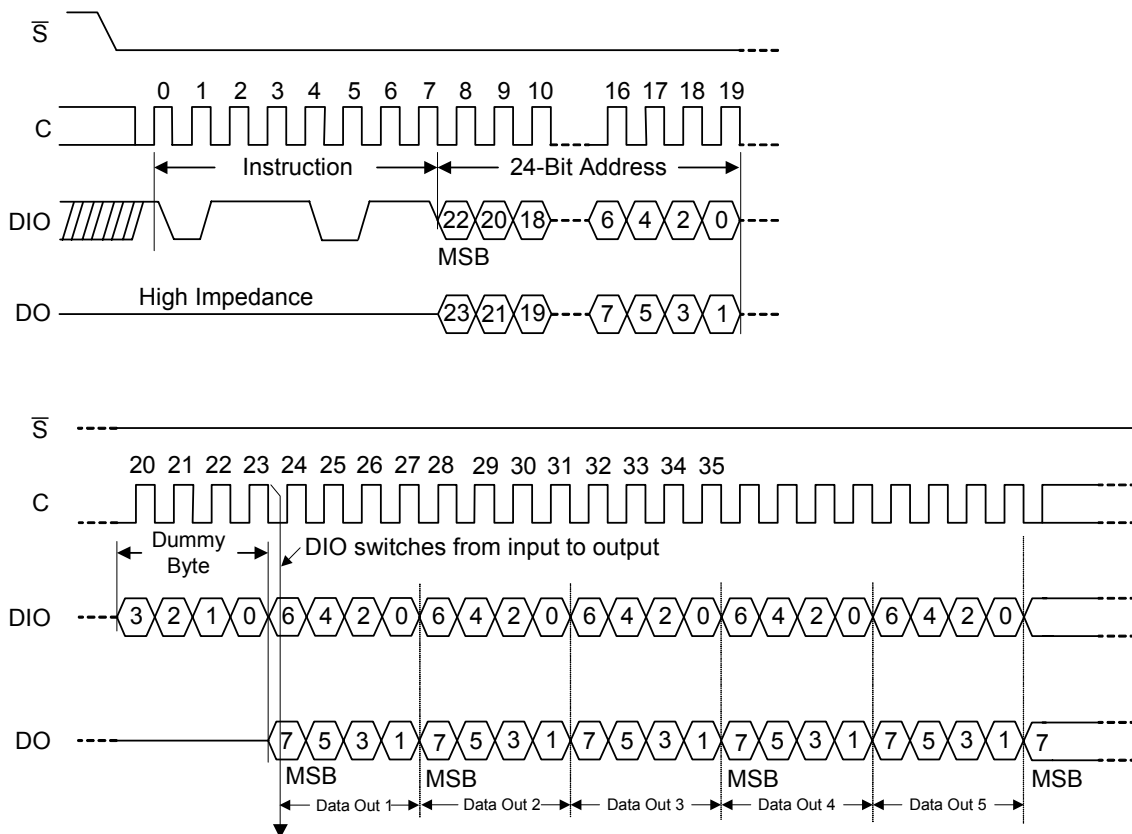

Note: Address bits A23 to A21 are Don't Care, for A25L016.

### Page Program (PP)

The Page Program (PP) instruction allows bytes to be programmed in the memory (changing bits from 1 to 0). Before it can be accepted, a Write Enable (WREN) instruction must previously have been executed. After the Write Enable (WREN) instruction has been decoded, the device sets the Write Enable Latch (WEL).

The Page Program (PP) instruction is entered by driving Chip Select ( $\bar{S}$ ) Low, followed by the instruction code, three address bytes and at least one data byte on Serial Data Input (DIO). If the 8 least significant address bits (A7-A0) are not all zero, all transmitted data that goes beyond the end of the current page are programmed from the start address of the same page (from the address whose 8 least significant bits (A7-A0) are all zero). Chip Select ( $\bar{S}$ ) must be driven Low for the entire duration of the sequence.

The instruction sequence is shown in Figure 12. If more than 256 bytes are sent to the device, previously latched data are discarded and the last 256 data bytes are guaranteed to be

programmed correctly within the same page. If less than 256 Data bytes are sent to device, they are correctly programmed at the requested addresses without having any effects on the other bytes of the same page.

Chip Select ( $\bar{S}$ ) must be driven High after the eighth bit of the last data byte has been latched in, otherwise the Page Program (PP) instruction is not executed.

As soon as Chip Select ( $\bar{S}$ ) is driven High, the self-timed Page Program cycle (whose duration is  $t_{PP}$ ) is initiated. While the Page Program cycle is in progress, the Status Register may be read to check the value of the Write In Progress (WIP) bit. The Write In Progress (WIP) bit is 1 during the self-timed Page Program cycle, and is 0 when it is completed. At some unspecified time before the cycle is completed, the Write Enable Latch (WEL) bit is reset.

A Page Program (PP) instruction applied to a page which is protected by the Block Protect (BP2, BP1, BP0) bits (see table 1 and table 2) is not executed.

**Figure 12. Page Program (PP) Instruction Sequence**

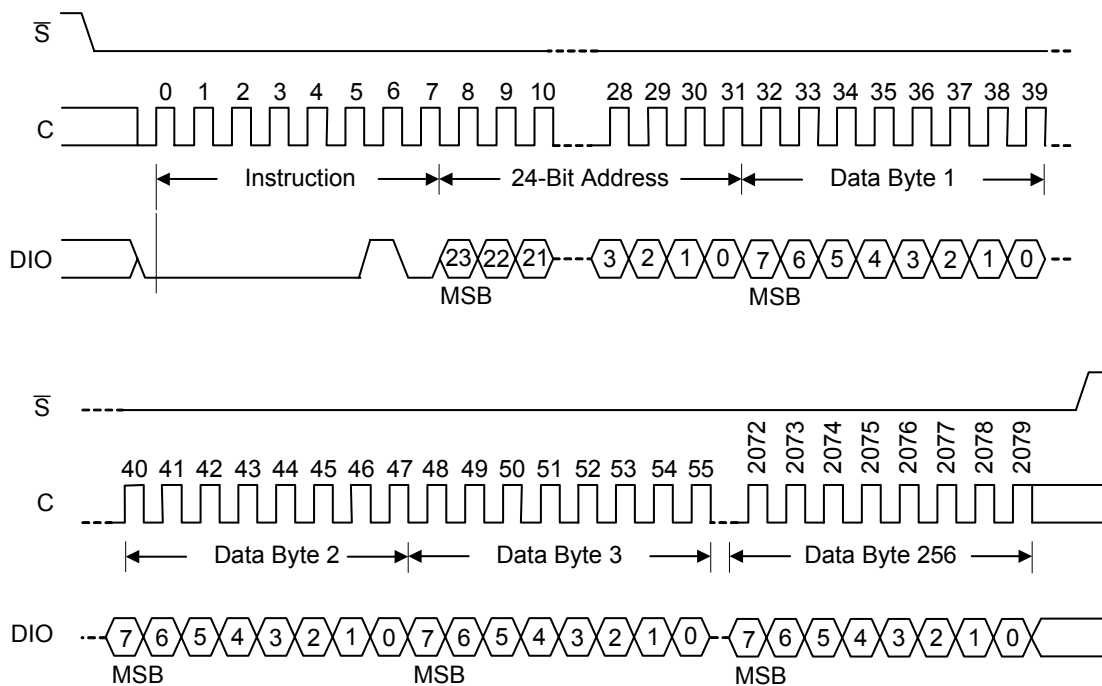

Note:.. Address bits A23 to A21 are Don't Care, for A25L016.

### Sector Erase (SE)

The Sector Erase (SE) instruction sets to 1 (FFh) all bits inside the chosen sector. Before it can be accepted, a Write Enable (WREN) instruction must previously have been executed. After the Write Enable (WREN) instruction has been decoded, the device sets the Write Enable Latch (WEL).

The Sector Erase (SE) instruction is entered by driving Chip Select ( $\bar{S}$ ) Low, followed by the instruction code on Serial Data Input (DIO). Chip Select ( $\bar{S}$ ) must be driven Low for the entire duration of the sequence.

The instruction sequence is shown in Figure 13. Chip Select ( $\bar{S}$ ) must be driven High after the eighth bit of the instruction code has been latched in, otherwise the Sector Erase

instruction is not executed. As soon as Chip Select ( $\bar{S}$ ) is driven High, the self-timed Sector Erase cycle (whose duration is  $t_{SE}$ ) is initiated. While the Sector Erase cycle is in progress, the Status Register may be read to check the value of the Write In Progress (WIP) bit. The Write In Progress (WIP) bit is 1 during the self-timed Sector Erase cycle, and is 0 when it is completed. At some unspecified time before the cycle is completed, the Write Enable Latch (WEL) bit is reset. A Sector Erase (SE) instruction applied to a page which is protected by the Block Protect (BP2, BP1, BP0) bits (see table 1 and table 2) is not executed.

**Figure 13. Sector Erase (SE) Instruction Sequence**

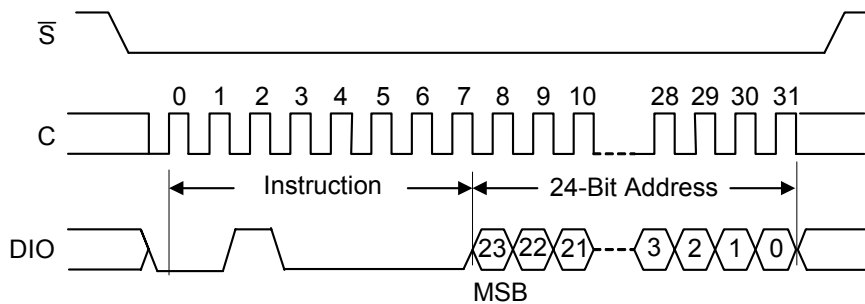

Note:.. Address bits A23 to A21 are Don't Care, for A25L016.

### Block Erase (BE)

The Block Erase (BE) instruction sets to 1 (FFh) all bits inside the chosen block. Before it can be accepted, a Write Enable (WREN) instruction must previously have been executed. After the Write Enable (WREN) instruction has been decoded, the device sets the Write Enable Latch (WEL).

The Block Erase (BE) instruction is entered by driving Chip Select ( $\bar{S}$ ) Low, followed by the instruction code on Serial Data Input (DIO). Chip Select ( $\bar{S}$ ) must be driven Low for the entire duration of the sequence.

The instruction sequence is shown in Figure 14. Chip Select ( $\bar{S}$ ) must be driven High after the eighth bit of the instruction code has been latched in, otherwise the Block Erase

instruction is not executed. As soon as Chip Select ( $\bar{S}$ ) is driven High, the self-timed Block Erase cycle (whose duration is  $t_{BE}$ ) is initiated. While the Block Erase cycle is in progress, the Status Register may be read to check the value of the Write In Progress (WIP) bit. The Write In Progress (WIP) bit is 1 during the self-timed Block Erase cycle, and is 0 when it is completed. At some unspecified time before the cycle is completed, the Write Enable Latch (WEL) bit is reset. A Block Erase (BE) instruction applied to a page which is protected by the Block Protect (BP2, BP1, BP0) bits (see table 1 and table 2) is not executed.

**Figure 14. Block Erase (BE) Instruction Sequence**

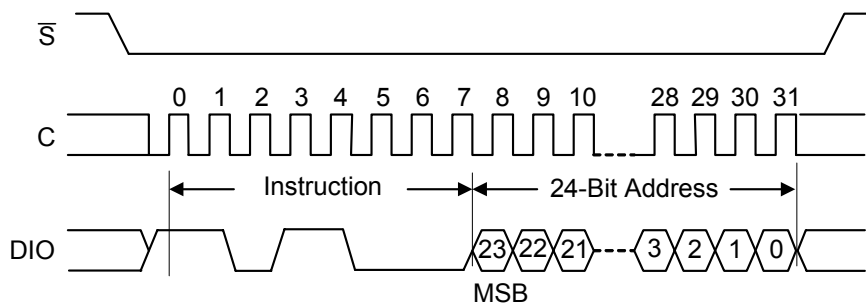

Note: Address bits A23 to A21 are Don't Care, for A25L016.

### Chip Erase (CE)

The Chip Erase (CE) instruction sets all bits to 1 (FFh). Before it can be accepted, a Write Enable (WREN) instruction must previously have been executed. After the Write Enable (WREN) instruction has been decoded, the device sets the Write Enable Latch (WEL).

The Chip Erase (CE) instruction is entered by driving Chip Select ( $\bar{S}$ ) Low, followed by the instruction code on Serial Data Input (DIO). Chip Select ( $\bar{S}$ ) must be driven Low for the entire duration of the sequence.

The instruction sequence is shown in Figure 15. Chip Select ( $\bar{S}$ ) must be driven High after the eighth bit of the instruction code has been latched in, otherwise the Block Erase

instruction is not executed. As soon as Chip Select ( $\bar{S}$ ) is driven High, the self-timed Chip Erase cycle (whose duration is  $t_{CE}$ ) is initiated. While the Chip Erase cycle is in progress, the Status Register may be read to check the value of the Write In Progress (WIP) bit. The Write In Progress (WIP) bit is 1 during the self-timed Chip Erase cycle, and is 0 when it is completed. At some unspecified time before the cycle is completed, the Write Enable Latch (WEL) bit is reset. The Chip Erase (CE) instruction is executed only if all Block Protect (BP2, BP1, BP0) bits are 0. The Chip Erase (CE) instruction is ignored if one, or more, blocks are protected.

**Figure 15. Chip Erase (CE) Instruction Sequence**

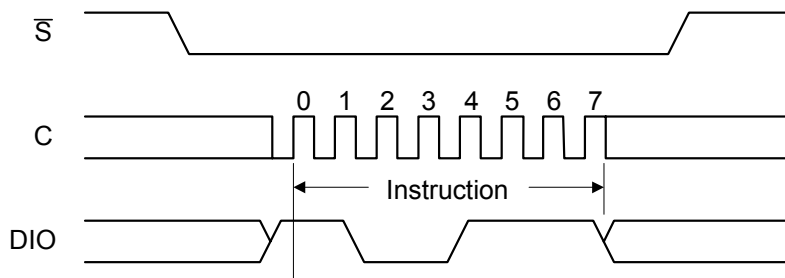

Note:.. Address bits A23 to A21 are Don't Care, for A25L016.

### Deep Power-down (DP)

Executing the Deep Power-down (DP) instruction is the only way to put the device in the lowest consumption mode (the Deep Power-down mode). It can also be used as an extra software protection mechanism, while the device is not in active use, since in this mode, the device ignores all Write, Program and Erase instructions.

Driving Chip Select ( $\bar{S}$ ) High deselects the device, and puts the device in the Standby mode (if there is no internal cycle currently in progress). But this mode is not the Deep Power-down mode. The Deep Power-down mode can only be entered by executing the Deep Power-down (DP) instruction, to reduce the standby current (from  $I_{CC1}$  to  $I_{CC2}$ , as specified in DC Characteristics Table.).

Once the device has entered the Deep Power-down mode, all instructions are ignored except the Release from Deep Power-down and Read Electronic Signature (RES) instruction. This releases the device from this mode. The Release from Deep Power-down and Read Electronic Signature (RES) instruction also allows the Electronic Signature of the device to be output on Serial Data Output (DO).

The Deep Power-down mode automatically stops at Power-down, and the device always Powers-up in the Standby mode.

The Deep Power-down (DP) instruction is entered by driving Chip Select ( $\bar{S}$ ) Low, followed by the instruction code on Serial Data Input (DIO). Chip Select ( $\bar{S}$ ) must be driven Low for the entire duration of the sequence. The instruction sequence is shown in Figure 16.

Chip Select ( $\bar{S}$ ) must be driven High after the eighth bit of the instruction code has been latched in, otherwise the Deep Power-down (DP) instruction is not executed. As soon as Chip Select ( $\bar{S}$ ) is driven High, it requires a delay of  $t_{DP}$  before the supply current is reduced to  $I_{CC2}$  and the Deep Power-down mode is entered.

Any Deep Power-down (DP) instruction, while an Erase, Program or Write cycle is in progress, is rejected without having any effects on the cycle that is in progress.

**Figure 16. Deep Power-down (DP) Instruction Sequence**

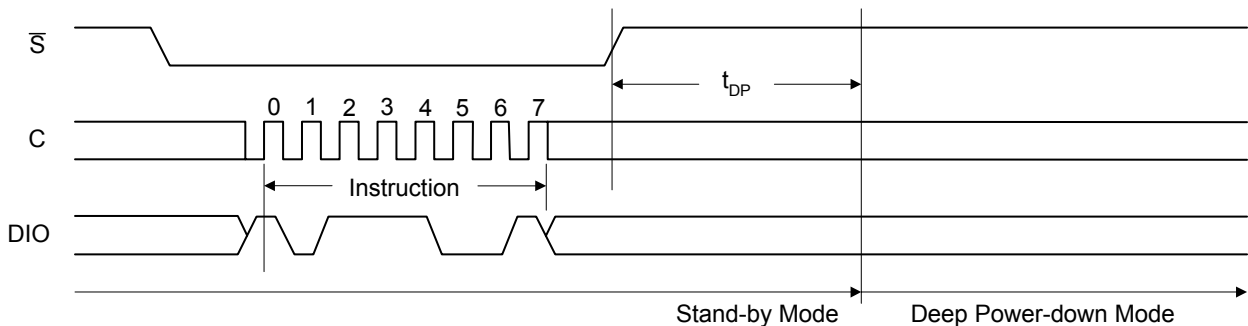



### Read Device Identification (RDID)

The Read Identification (RDID) instruction allows the 8-bit manufacturer identification code to be read, followed by two bytes of device identification. The manufacturer identification is assigned by JEDEC, and has the value 37h. The device identification is assigned by the device manufacturer, and indicates the memory in the first bytes (30h), and the memory capacity of the device in the second byte (15h for A25L016). Any Read Identification (RDID) instruction while an Erase, or Program cycle is in progress, is not decoded, and has no effect on the cycle that is in progress.

The device is first selected by driving Chip Select ( $\bar{S}$ ) Low. Then, the 8-bit instruction code for the instruction is shifted in.

This is followed by the 24-bit device identification, stored in the memory, being shifted out on Serial Data Output (DO), each bit being shifted out during the falling edge of Serial Clock (C).

The instruction sequence is shown in Figure 17. The Read Identification (RDID) instruction is terminated by driving Chip Select ( $\bar{S}$ ) High at any time during data output.

When Chip Select ( $\bar{S}$ ) is driven High, the device is put in the Stand-by Power mode. Once in the Stand-by Power mode, the device waits to be selected, so that it can receive, decode and execute instructions.

**Table 6. Read Identification (READ\_ID) Data-Out Sequence**

Manufacture Identification	Device Identification	
Manufacture ID	Memory Type	Memory Capacity
37h	30h	15h

**Figure 17. Read Identification (RDID) Instruction Sequence and Data-Out Sequence**

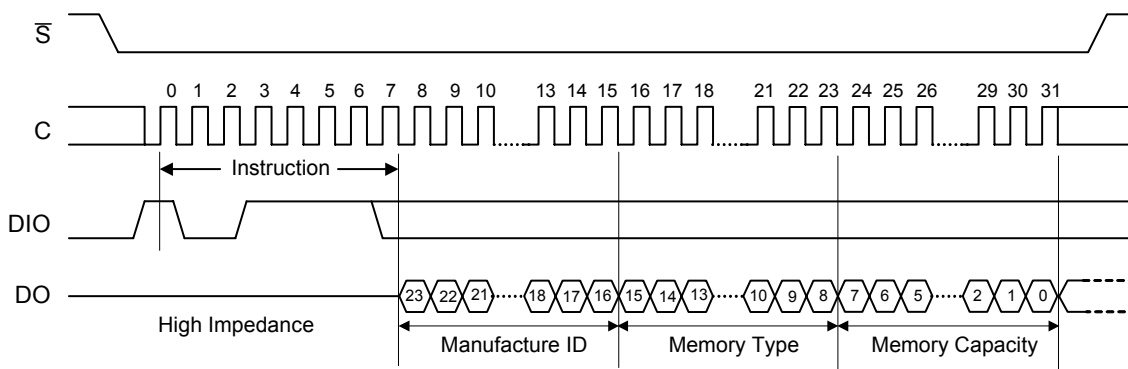

### Read Electronic Manufacturer ID & Device ID (REMS)

The Read Electronic Manufacturer ID & Device ID (REMS) instruction allows the 8-bit manufacturer identification code to be read, followed by one byte of device identification. The manufacturer identification is assigned by JEDEC, and has the value 37h. The device identification is assigned by the device manufacturer, and has the value 14h for A25L016.

Any Read Electronic Manufacturer ID & Device ID (REMS) instruction while an Erase, or Program cycle is in progress, is not decoded, and has no effect on the cycle that is in progress.

The device is first selected by driving Chip Select ( $\bar{S}$ ) Low. The 8-bit instruction code is followed by 2 dummy bytes and one byte address (A7~A0), each bit being latched-in on Serial Data Input (DIO) during the rising edge of Serial Clock (C).

If the one-byte address is set to 01h, then the device ID will be read first and then followed by the Manufacturer ID. On the other hand, if the one-byte address is set to 00h, then the Manufacturer ID will be read first and then followed by the device ID.

The instruction sequence is shown in Figure 18. The Read Electronic Manufacturer ID & Device ID (REMS) instruction is terminated by driving Chip Select ( $\bar{S}$ ) High at any time during data output.

When Chip Select ( $\bar{S}$ ) is driven High, the device is put in the Stand-by Power mode. Once in the Stand-by Power mode, the device waits to be selected, so that it can receive, decode and execute instructions.

**Table 7. Read Electronic Manufacturer ID & Device ID (REMS) Data-Out Sequence**

Manufacture Identification	Device Identification
37h	14h

**Figure 18. Read Electronic Manufacturer ID & Device ID (REMS) Instruction Sequence and Data-Out Sequence**

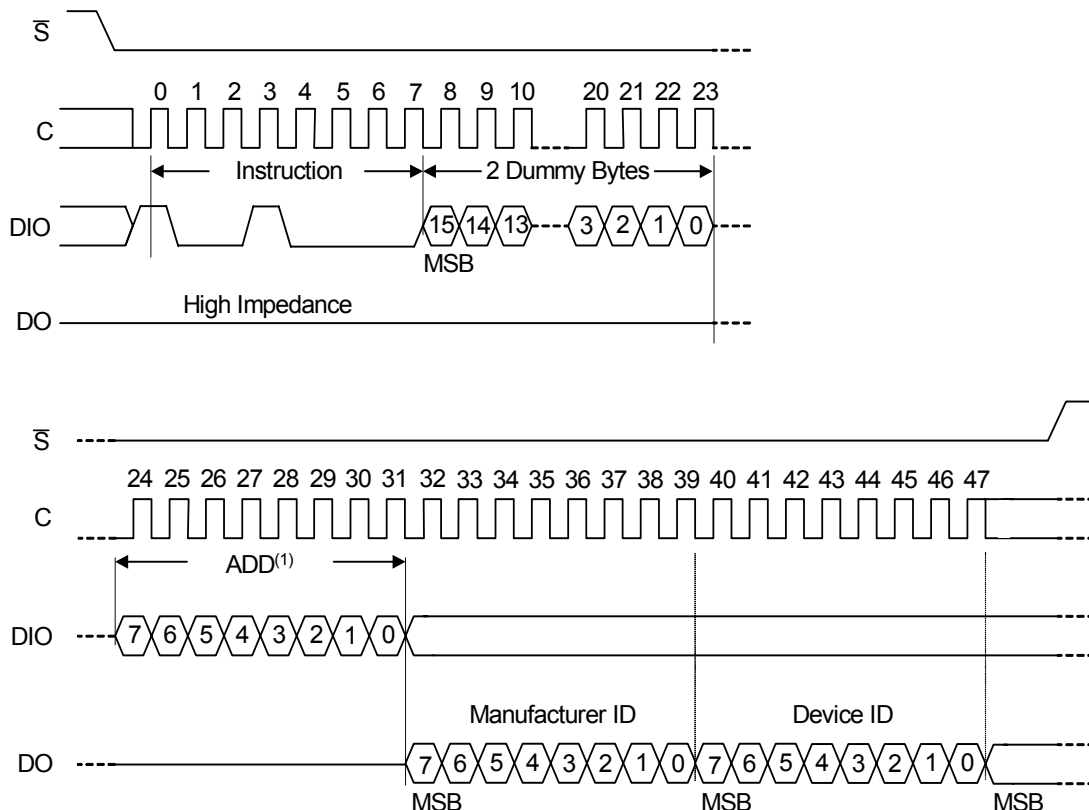

Notes:

(1) ADD=00h will output the manufacturer ID first and ADD=01h will output device ID first

### Release from Deep Power-down and Read Electronic Signature (RES)

Once the device has entered the Deep Power-down mode, all instructions are ignored except the Release from Deep Power-down and Read Electronic Signature (RES) instruction. Executing this instruction takes the device out of the Deep Power-down mode.

The instruction can also be used to read, on Serial Data Output (DO), the 8-bit Electronic Signature, whose value for A25L016 is 14h.

Except while an Erase, Program or Write Status Register cycle is in progress, the Release from Deep Power-down and Read Electronic Signature (RES) instruction always provides access to the 8-bit Electronic Signature of the device, and can be applied even if the Deep Power-down mode has not been entered.

Any Release from Deep Power-down and Read Electronic Signature (RES) instruction while an Erase, Program or Write Status Register cycle is in progress, is not decoded, and has no effect on the cycle that is in progress.

The device is first selected by driving Chip Select ( $\bar{S}$ ) Low. The instruction code is followed by 3 dummy bytes, each bit being latched-in on Serial Data Input (DIO) during the rising

edge of Serial Clock (C). Then, the 8-bit Electronic Signature, stored in the memory, is shifted out on Serial Data Output (DO), each bit being shifted out during the falling edge of Serial Clock (C).

The instruction sequence is shown in Figure 19.

The Release from Deep Power-down and Read Electronic Signature (RES) instruction is terminated by driving Chip Select ( $\bar{S}$ ) High after the Electronic Signature has been read at least once. Sending additional clock cycles on Serial Clock (C), while Chip Select ( $\bar{S}$ ) is driven Low, cause the Electronic Signature to be output repeatedly.

When Chip Select ( $\bar{S}$ ) is driven High, the device is put in the Stand-by Power mode. If the device was not previously in the Deep Power-down mode, the transition to the Stand-by Power mode is immediate. If the device was previously in the Deep Power-down mode, though, the transition to the Stand-by Power mode is delayed by  $t_{RES2}$ , and Chip Select ( $\bar{S}$ ) must remain High for at least  $t_{RES2}(\max)$ , as specified in AC Characteristics Table . Once in the Stand-by Power mode, the device waits to be selected, so that it can receive, decode and execute instructions.

**Figure 19. Release from Deep Power-down and Read Electronic Signature (RES) Instruction Sequence and Data-Out Sequence**

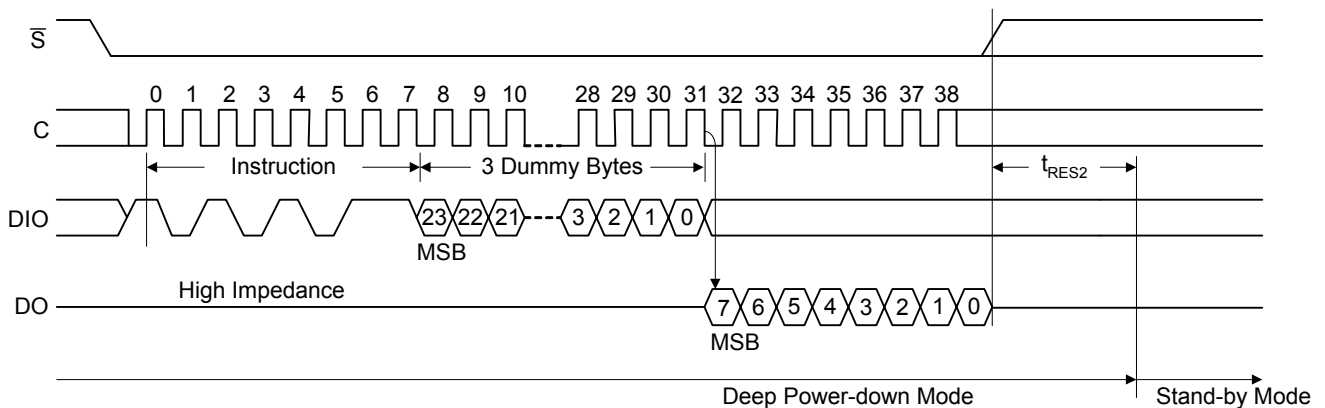

Note: The value of the 8-bit Electronic Signature is 14h.

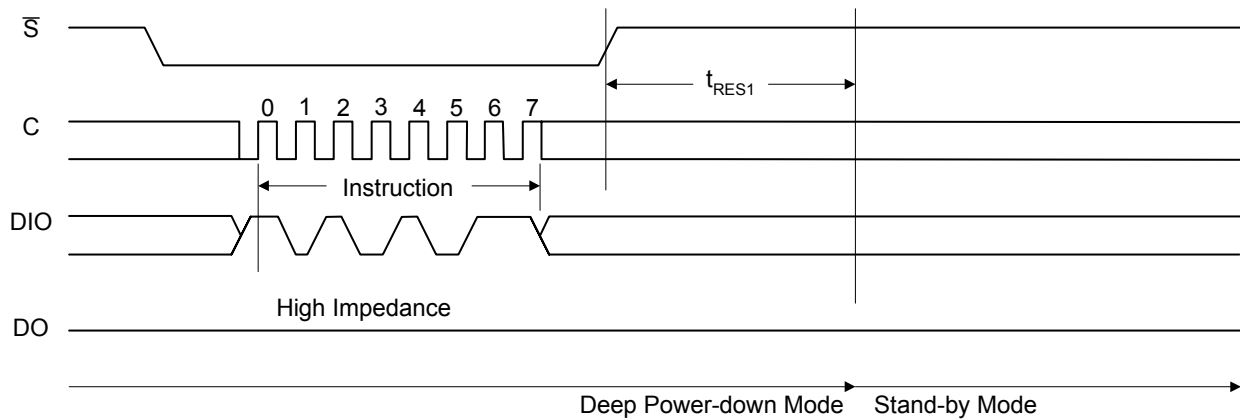
**Figure 20. Release from Deep Power-down (RES) Instruction Sequence**

Driving Chip Select ( $\bar{S}$ ) High after the 8-bit instruction byte has been received by the device, but before the whole of the 8-bit Electronic Signature has been transmitted for the first time (as shown in Figure 20.), still insures that the device is put into Stand-by Power mode. If the device was not previously in the Deep Power-down mode, the transition to the Stand-by Power mode is immediate. If the device was

previously in the Deep Power-down mode, though, the transition to the Stand-by Power mode is delayed by  $t_{RES1}$ , and Chip Select ( $\bar{S}$ ) must remain High for at least  $t_{RES1}(\max)$ , as specified in AC Characteristics Table. Once in the Stand-by Power mode, the device waits to be selected, so that it can receive, decode and execute instructions.

## POWER-UP AND POWER-DOWN

At Power-up and Power-down, the device must not be selected (that is Chip Select ( $\bar{S}$ ) must follow the voltage applied on  $V_{CC}$ ) until  $V_{CC}$  reaches the correct value:

- $V_{CC}(\text{min})$  at Power-up, and then for a further delay of  $t_{VSL}$
- $V_{SS}$  at Power-down

Usually a simple pull-up resistor on Chip Select ( $\bar{S}$ ) can be used to insure safe and proper Power-up and Power-down.

To avoid data corruption and inadvertent write operations during power up, a Power On Reset (POR) circuit is included. The logic inside the device is held reset while  $V_{CC}$  is less than the POR threshold value,  $V_{WI}$  – all operations are disabled, and the device does not respond to any instruction.

Moreover, the device ignores all Write Enable (WREN), Page Program (PP), Sector Erase (SE), Block Erase (BE), Chip Erase (CE) and Write Status Register (WRSR) instructions until a time delay of  $t_{PUW}$  has elapsed after the moment that  $V_{CC}$  rises above the VWI threshold. However, the correct operation of the device is not guaranteed if, by this time,  $V_{CC}$  is still below  $V_{CC}(\text{min})$ . No Write Status Register, Program or Erase instructions should be sent until the later of:

- $t_{PUW}$  after  $V_{CC}$  passed the VWI threshold
- $t_{VSL}$  after  $V_{CC}$  passed the  $V_{CC}(\text{min})$  level

These values are specified in Table 8.

If the delay,  $t_{VSL}$ , has elapsed, after  $V_{CC}$  has risen above  $V_{CC}(\text{min})$ , the device can be selected for READ instructions even if the  $t_{PUW}$  delay is not yet fully elapsed.

At Power-up, the device is in the following state:

- The device is in the Standby mode (not the Deep Power-down mode).
- The Write Enable Latch (WEL) bit is reset.

Normal precautions must be taken for supply rail decoupling, to stabilize the  $V_{CC}$  feed. Each device in a system should have the  $V_{CC}$  rail decoupled by a suitable capacitor close to the package pins. (Generally, this capacitor is of the order of 0.1 $\mu\text{F}$ ).

At Power-down, when  $V_{CC}$  drops from the operating voltage, to below the POR threshold value,  $V_{WI}$ , all operations are disabled and the device does not respond to any instruction. (The designer needs to be aware that if a Power-down occurs while a Write, Program or Erase cycle is in progress, some data corruption can result.)

**Figure 21. Power-up Timing**

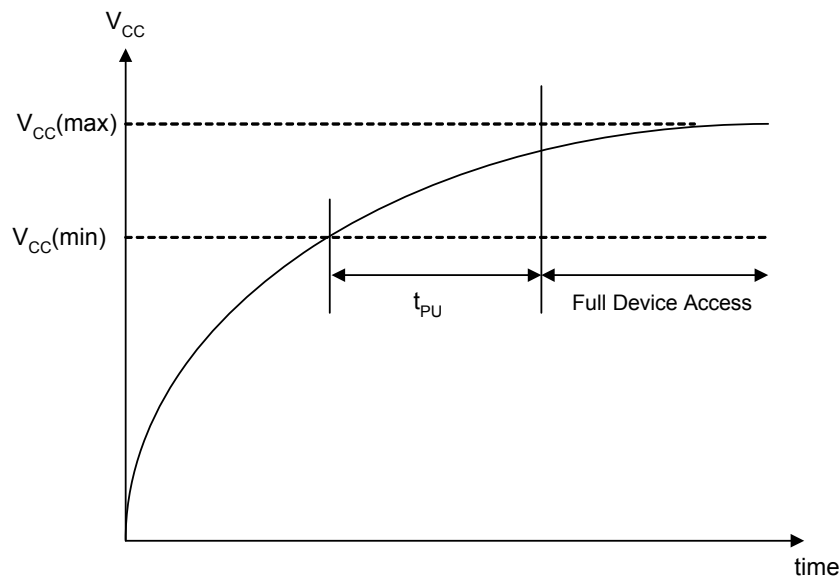

**Table 8. Power-Up Timing**

Symbol	Parameter	Min.	Max.	Unit
$V_{CC(min)}$	$V_{CC}$ (minimum)	2.7		V
$t_{PU}$	$V_{CC}$ (min) to device operation	5		ms

Note: These parameters are characterized only.

**INITIAL DELIVERY STATE**

The device is delivered with the memory array erased: all bits are set to 1 (each byte contains FFh). The Status Register contains 00h (all Status Register bits are 0).

**Absolute Maximum Ratings\***

Storage Temperature (TSTG) . . . . .	-65°C to + 150°C
Lead Temperature during Soldering (Note 1)	
D.C. Voltage on Any Pin to Ground Potential . . . . .	-0.6V to VCC+0.6V
Transient Voltage (<20ns) on Any Pin to Ground Potential . . . . .	-2.0V to VCC+2.0V
Supply Voltage (VCC) . . . . .	-0.6V to +4.0V
Electrostatic Discharge Voltage (Human Body model) (VESD) (Note 2) . . . . .	-2000V to 2000V

**Notes:**

- Compliant with JEDEC Std J-STD-020B (for small body, Sn-Pb or Pb assembly).
- JEDEC Std JESD22-A114A (C1=100 pF, R1=1500 Ω, R2=500 Ω)

**\*Comments**

Stressing the device above the rating listed in the Absolute Maximum Ratings" table may cause permanent damage to the device. These are stress ratings only and operation of the device at these or any other conditions above those indicated in the Operating sections of this specification is not implied. Exposure to Absolute Maximum Rating conditions for extended periods may affect device reliability. Refer also to the AMIC SURE Program and other relevant quality documents.

**DC AND AC PARAMETERS**

This section summarizes the operating and measurement conditions, and the DC and AC characteristics of the device. The parameters in the DC and AC Characteristic tables that follow are derived from tests performed under the

Measurement Conditions summarized in the relevant tables. Designers should check that the operating conditions in their circuit match the measurement conditions when relying on the quoted parameters.

**Table 9. Operating Conditions**

Symbol	Parameter	Min.	Max.	Unit
V <sub>CC</sub>	Supply Voltage	2.7	3.6	V
T <sub>A</sub>	Ambient Operating Temperature	-40	85	°C

**Table 10. Data Retention and Endurance**

Parameter	Condition	Min.	Max.	Unit
Erase/Program Cycles	At 85°C	100,000		Cycles
Data Retention	At 85°C	20		Years

**Table 11. Capacitance**

Symbol	Parameter	Test Condition	Min.	Max.	Unit
C <sub>OUT</sub>	Output Capacitance (DO)	V <sub>OUT</sub> = 0V		8	pF
C <sub>IN</sub>	Input Capacitance (other pins)	V <sub>IN</sub> = 0V		6	pF

Note: Sampled only, not 100% tested, at T<sub>A</sub>=25°C and a frequency of 33 MHz.

**Table 12. DC Characteristics**

Symbol	Parameter	Test Condition	Min.	Max.	Unit
I <sub>LI</sub>	Input Leakage Current			± 2	μA
I <sub>LO</sub>	Output Leakage Current			± 2	μA
I <sub>CC1</sub>	Standby Current	$\bar{S} = V_{CC}, V_{IN} = V_{SS} \text{ or } V_{CC}$		25	μA
I <sub>CC2</sub>	Deep Power-down Current	$\bar{S} = V_{CC}, V_{IN} = V_{SS} \text{ or } V_{CC}$		25	μA
I <sub>CC3</sub>	Operating Current (READ)	C= 0.1V <sub>CC</sub> / 0.9.V <sub>CC</sub> at 100MHz, DO = open		35	mA
		C= 0.1V <sub>CC</sub> / 0.9.V <sub>CC</sub> at 50MHz, DO = open		30	mA
		C= 0.1V <sub>CC</sub> / 0.9.V <sub>CC</sub> at 33MHz, DO = open		25	mA
I <sub>CC4</sub>	Operating Current (PP)	$\bar{S} = V_{CC}$		15	mA
I <sub>CC5</sub>	Operating Current (WRSR)	$\bar{S} = V_{CC}$		15	mA
I <sub>CC6</sub>	Operating Current (SE)	$\bar{S} = V_{CC}$		25	mA
I <sub>CC7</sub>	Operating Current (BE)	$\bar{S} = V_{CC}$		25	mA
V <sub>IL</sub>	Input Low Voltage		-0.5	0.3V <sub>CC</sub>	V
V <sub>IH</sub>	Input High Voltage		0.7V <sub>CC</sub>	V <sub>CC</sub> +0.4	V
V <sub>OL</sub>	Output Low Voltage	I <sub>OL</sub> = 1.6mA		0.4	V
V <sub>OH</sub>	Output High Voltage	I <sub>OH</sub> = -100μA	V <sub>CC</sub> -0.2		V

Note: 1. This is preliminary data at 85°C

**Table 13. Instruction Times**

Symbol	Alt.	Parameter	Min.	Typ.	Max.	Unit
t <sub>W</sub>		Write Status Register Cycle Time		5	20	ms
t <sub>PP</sub>		Page Program Cycle Time		2	3	ms
t <sub>SE</sub>		Sector Erase Cycle Time		0.08	0.2	s
t <sub>BE</sub>		Block Erase Cycle Time		0.5	2	s
t <sub>CE</sub>		Chip Erase Cycle Time		16	32	s

Note: 1. At 85°C

2. This is preliminary data

**Table 14. AC Measurement Conditions**

Symbol	Parameter	Min.	Max.	Unit
C <sub>L</sub>	Load Capacitance	30		pF
	Input Rise and Fall Times		5	ns
	Input Pulse Voltages	0.2V <sub>CC</sub> to 0.8V <sub>CC</sub>		V
	Input Timing Reference Voltages	0.3V <sub>CC</sub> to 0.7V <sub>CC</sub>		V
	Output Timing Reference Voltages	V <sub>CC</sub> / 2		V

Note: Output Hi-Z is defined as the point where data out is no longer driven.

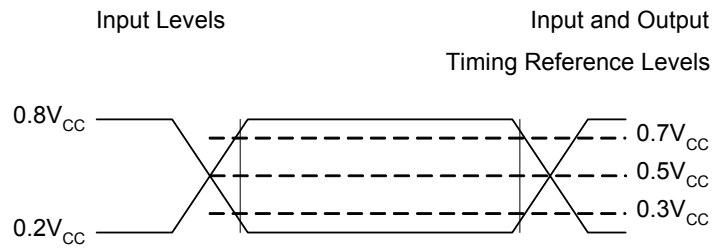
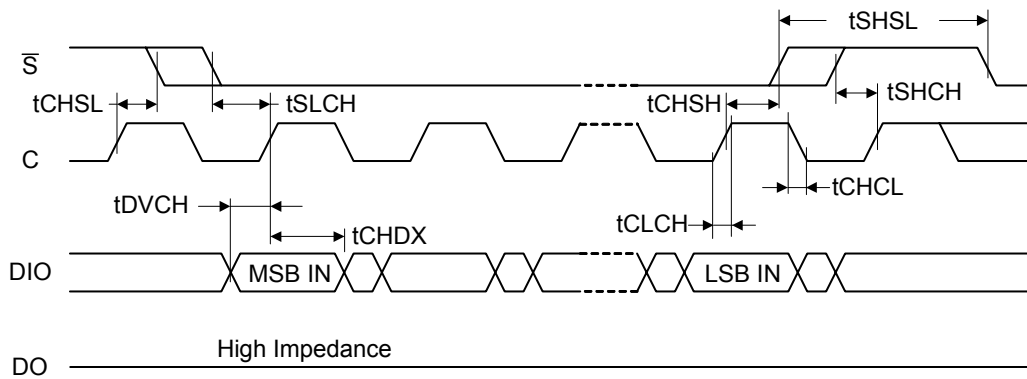
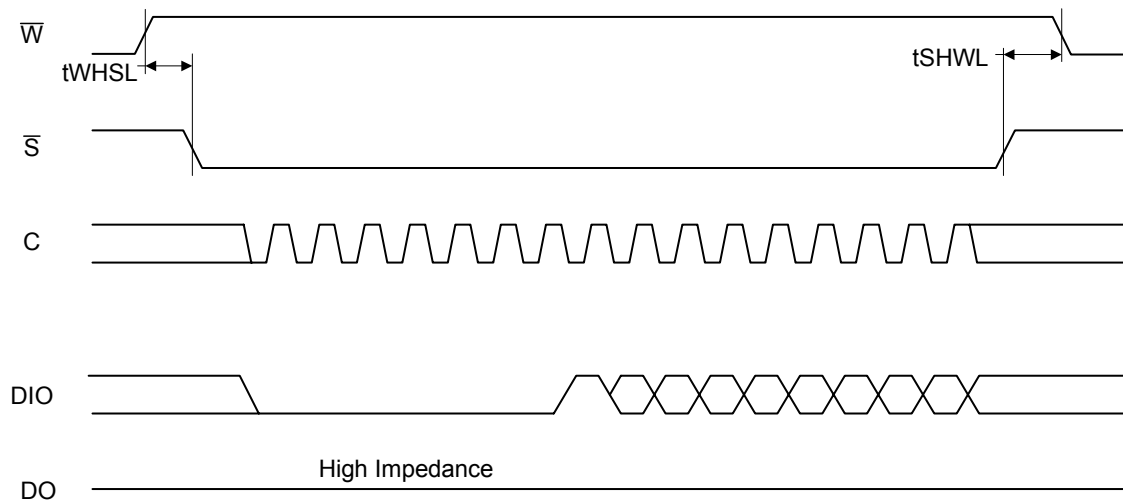

**Figure 22. AC Measurement I/O Waveform**

**Table 15. AC Characteristics**

Symbol	Alt.	Parameter	Min.	Typ.	Max.	Unit
$f_C$	$f_C$	Clock Frequency for the following instructions: FAST_READ, PP, SE, BE, DP, RES, RDID, WREN, WRDI, RDSR, WRSR	D.C.		100	MHz
$f_R$		Clock Frequency for READ instructions	D.C.		50	MHz
$t_{CH}^1$	$t_{CLH}$	Clock High Time	6			ns
$t_{CL}^1$	$t_{CLL}$	Clock Low Time	5			ns
$t_{CLCH}^2$		Clock Rise Time <sup>3</sup> (peak to peak)	0.1			V/ns
$t_{CHCL}^2$		Clock Fall Time <sup>3</sup> (peak to peak)	0.1			V/ns
$t_{SLCH}$	$t_{CSS}$	$\bar{S}$ Active Setup Time (relative to C)	5			ns
$t_{CHSL}$		$\bar{S}$ Not Active Hold Time (relative to C)	5			ns
$t_{DVCH}$	$t_{DSU}$	Data In Setup Time	5			ns
$t_{CHDX}$	$t_{DH}$	Data In Hold Time	5			ns
$t_{CHSH}$		$\bar{S}$ Active Hold Time (relative to C)	5			ns
$t_{SHCH}$		$\bar{S}$ Not Active Setup Time (relative to C)	5			ns
$t_{SHSL}$	$t_{CSH}$	$\bar{S}$ Deselect Time	100			ns
$t_{SHQZ}^2$	$t_{DIS}$	Output Disable Time			8	ns
$t_{CLQV}$	$t_V$	Clock Low to Output Valid			8	ns
$t_{CLQX}$	$t_{HO}$	Output Hold Time	0			ns
$t_{HLCH}$		$\overline{HOLD}$ Setup Time (relative to C)	5			ns
$t_{CHHH}$		$\overline{HOLD}$ Hold Time (relative to C)	5			ns
$t_{HHCH}$		HOLD Setup Time (relative to C)	5			ns
$t_{CHHL}$		HOLD Hold Time (relative to C)	5			ns
$t_{HHQX}^2$	$t_{LZ}$	HOLD to Output Low-Z			8	ns
$t_{HLQZ}^2$	$t_{HZ}$	$\overline{HOLD}$ to Output High-Z			8	ns
$t_{WHSL}^4$		Write Protect Setup Time	20			ns
$t_{SHWL}^4$		Write Protect Hold Time	100			ns
$t_{DP}^2$		$\bar{S}$ High to Deep Power-down Mode			3	$\mu$ s
$t_{RES1}^2$		$\bar{S}$ High to Standby Mode without Electronic Signature Read			30	$\mu$ s
$t_{RES2}^2$		$\bar{S}$ High to Standby Mode with Electronic Signature Read			30	$\mu$ s
$t_W$		Write Status Register Cycle Time		5	20	ms
$t_{PP}$		Page Program Cycle Time		2	3	ms
$t_{SE}$		Sector Erase Cycle Time		0.08	0.2	s
$t_{BE}$		Block Erase Cycle Time		0.5	2	s
$t_{CE}$		Chip Erase Cycle Time		16	32	s

- Note: 1.  $t_{CH} + t_{CL}$  must be greater than or equal to  $1/f_C$   
 2. Value guaranteed by characterization, not 100% tested in production.  
 3. Expressed as a slew-rate.  
 4. Only applicable as a constraint for a WRSR instruction when SRWD is set at 1.

**Figure 23. Serial Input Timing**

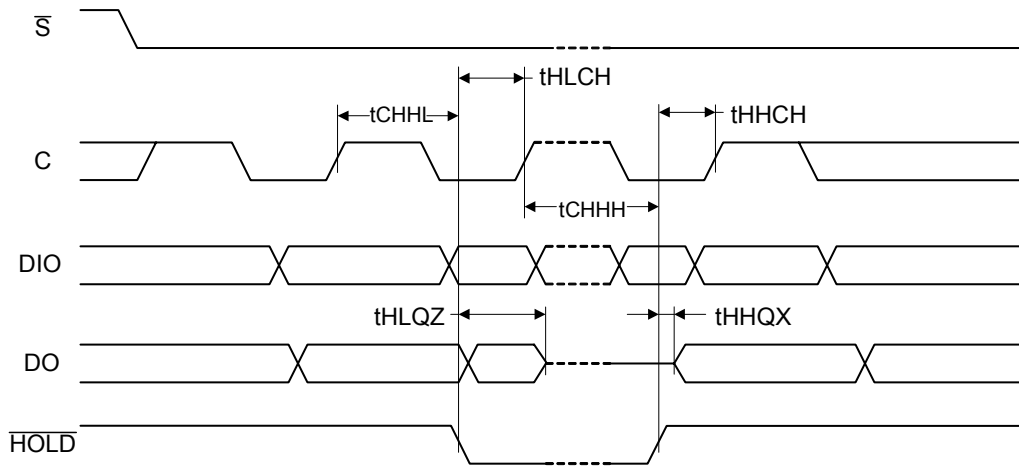
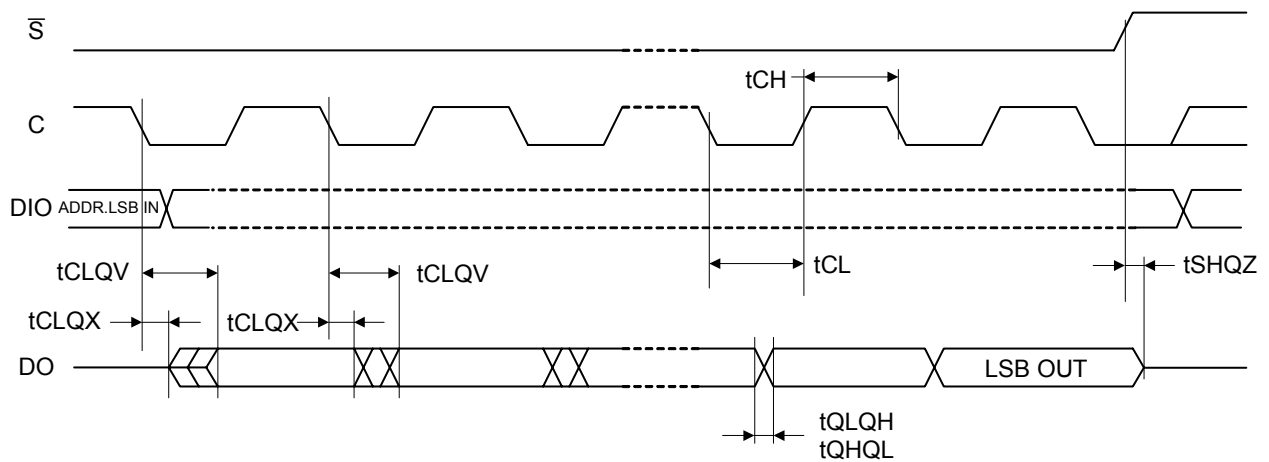
**Figure 24. Write Protect Setup and Hold Timing during WRSR when SRWD=1**

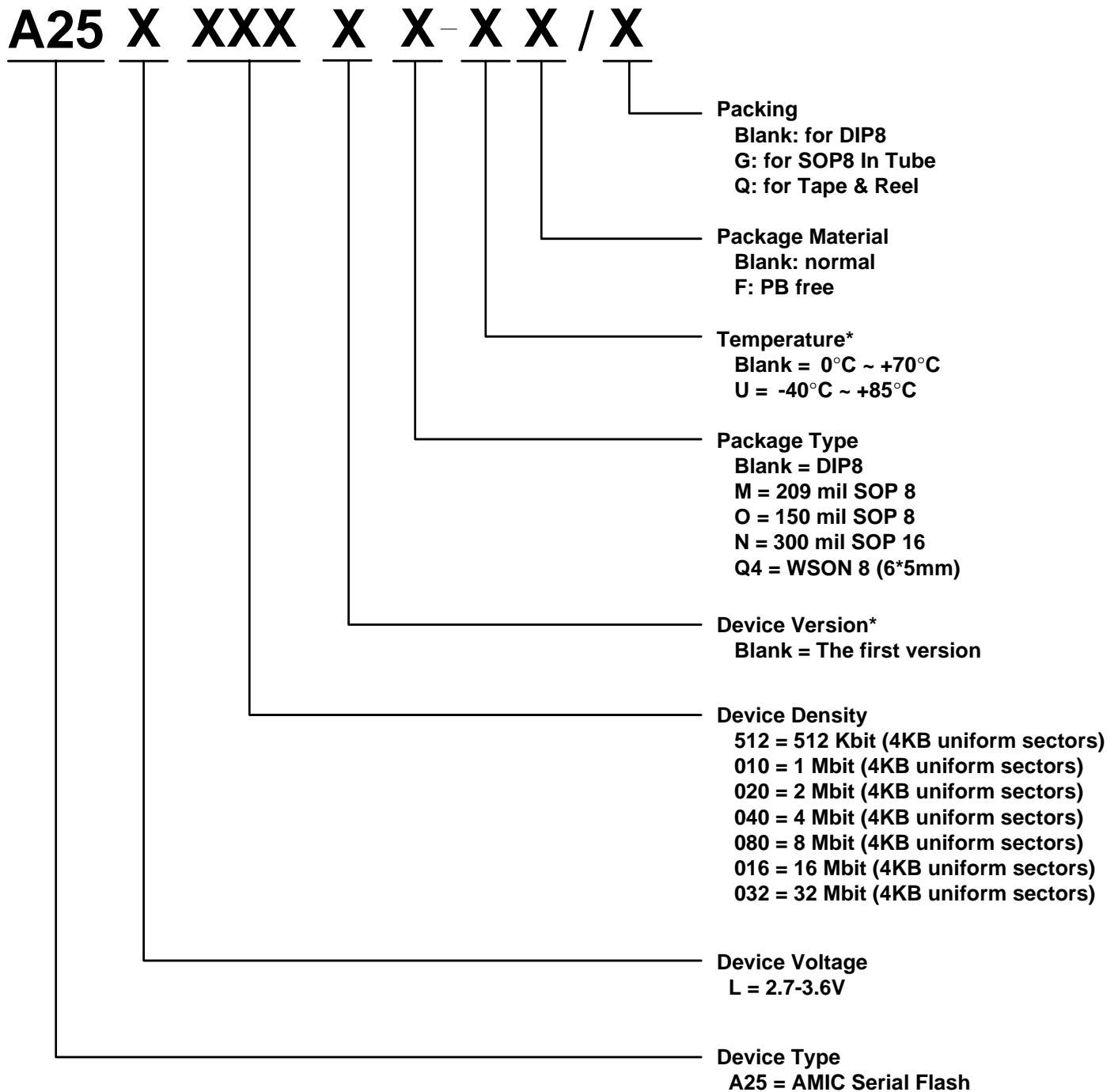
**Figure 25. Hold Timing**

**Figure 26. Output Timing**

**Part Numbering Scheme**

\* Optional

**Ordering Information**

Part No.	Speed (MHz)	Active Read Current Max. (mA)	Program/Erase Current Max. (mA)	Standby Current Max. ( $\mu$ A)	Package
A25L016-F	100	35	25	25	8 Pin Pb-Free DIP (300 mil)
A25L016-UF					8 Pin Pb-Free DIP (300 mil)
A25L016M-F					8 Pin Pb-Free SOP (209mil)
A25L016M-UF					8 Pin Pb-Free SOP (209mil)
A25L016O-F					8 Pin Pb-Free SOP (150 mil)
A25L016O-UF					8 Pin Pb-Free SOP (150 mil)
A25L016N-F					16 Pin Pb-Free SOP (300mil)
A25L016N-UF					16 Pin Pb-Free SOP (300mil)
A25L016Q4-F					8 Pin Pb-Free WSON (6*5mm)
					Operating temperature range: -40°C ~ +85°C

Blank is for commercial operating temperature range: 0°C ~ +70°C

-U is for industrial operating temperature range: -40°C ~ +85°C

**Package Information**
**P-DIP 8L Outline Dimensions**

unit: inches/mm

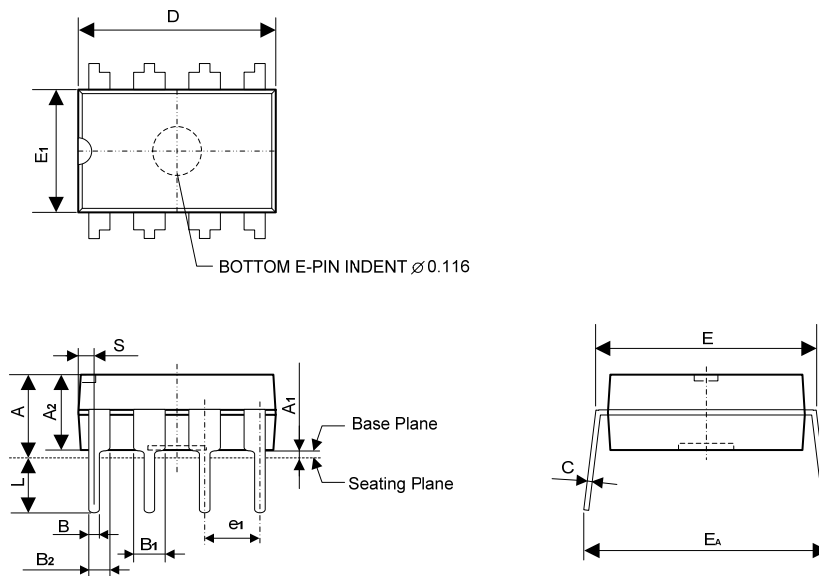

Symbol	Dimensions in inches			Dimensions in mm		
	Min	Nom	Max	Min	Nom	Max
A	-	-	0.180	-	-	4.57
A1	0.015	-	-	0.38	-	-
A2	0.128	0.130	0.136	3.25	3.30	3.45
B	0.014	0.018	0.022	0.36	0.46	0.56
B1	0.050	0.060	0.070	1.27	1.52	1.78
B2	0.032	0.039	0.046	0.81	0.99	1.17
C	0.008	0.010	0.013	0.20	0.25	0.33
D	0.350	0.360	0.370	8.89	9.14	9.40
E	0.290	0.300	0.315	7.37	7.62	8.00
E1	0.254	0.260	0.266	6.45	6.60	6.76
e1	-	0.100	-	-	2.54	-
L	0.125	-	-	3.18	-	-
EA	0.345	-	0.385	8.76	-	9.78
S	0.016	0.021	0.026	0.41	0.53	0.66

**Notes:**

1. Dimension D and E<sub>1</sub> do not include mold flash or protrusions.
2. Dimension B<sub>1</sub> does not include dambar protrusion.
3. Tolerance: ±0.010" (0.25mm) unless otherwise specified.

**Package Information**
**SOP 8L (150mil) Outline Dimensions**

unit: mm

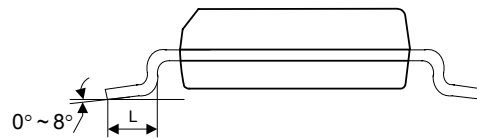
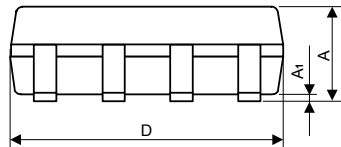
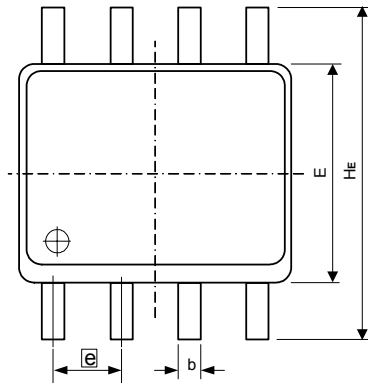

Symbol	Dimensions in mm
A	1.35~1.75
A1	0.10~0.25
b	0.33~0.51
D	4.7~5.0
E	3.80~4.00
e	1.27 BSC
HE	5.80~6.20
L	0.40~1.27

**Notes:**

1. Maximum allowable mold flash is 0.15mm.
2. Complies with JEDEC publication 95 MS -012 AA.
3. All linear dimensions are in millimeters (max/min).
4. Coplanarity: Max. 0.1mm



**Package Information**
**SOP 8L (209mil) Outline Dimensions**

unit: mm

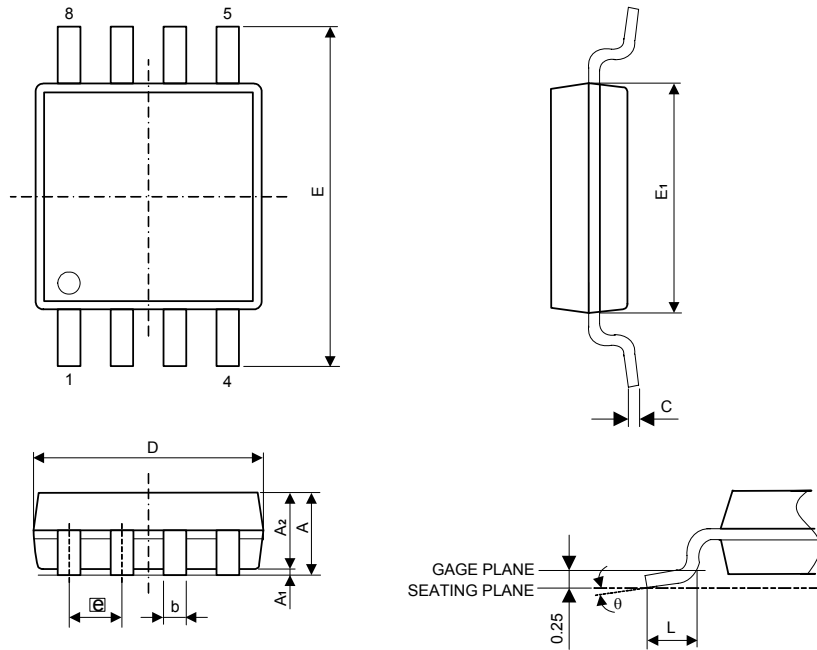

Symbol	Dimensions in mm		
	Min	Nom	Max
A	1.75	1.95	2.16
A <sub>1</sub>	0.05	0.15	0.25
A <sub>2</sub>	1.70	1.80	1.91
b	0.35	0.42	0.48
C	0.19	0.20	0.25
D	5.13	5.23	5.33
E	7.70	7.90	8.10
E <sub>1</sub>	5.18	5.28	5.38
e	1.27 BSC		
L	0.50	0.65	0.80
θ	0°	-	8°

**Notes:**

Maximum allowable mold flash is 0.15mm at the package ends and 0.25mm between leads

**Package Information**
**SOP 16L (300mil) Outline Dimensions**

unit: inches/mm

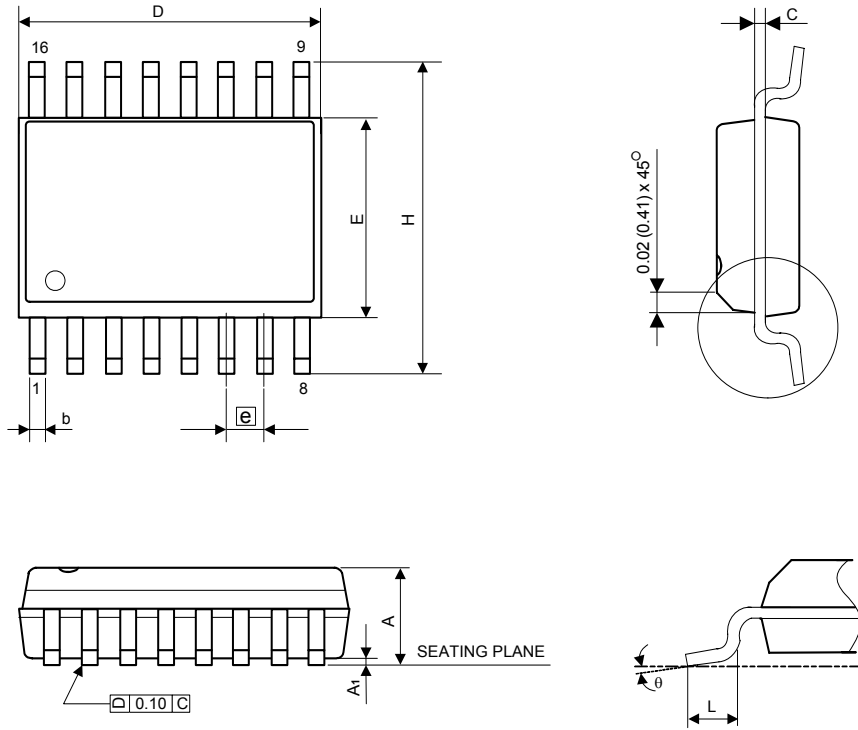

Symbol	Dimensions in inch		Dimensions in mm	
	Min	Max	Min	Max
A	0.093	0.104	2.36	2.65
A1	0.004	0.012	0.10	0.30
b	0.016 Typ.		0.41 Typ.	
C	0.008 Typ.		0.20 Typ.	
D	0.398	0.413	10.10	10.50
E	0.291	0.299	7.39	7.60
e	0.050 Typ.		1.27 Typ.	
H	0.394	0.419	10.01	10.64
L	0.016	0.050	0.40	1.27
θ	0°	8°	0°	8°

**Notes:**

1. Dimensions "D" does not include mold flash, protrusions or gate burrs.
2. Dimensions "E" does not include interlead flash, or protrusions.

**Package Information**
**WSO8 8L (6 X 5 X 0.8mm) Outline Dimensions**

unit: mm/mil

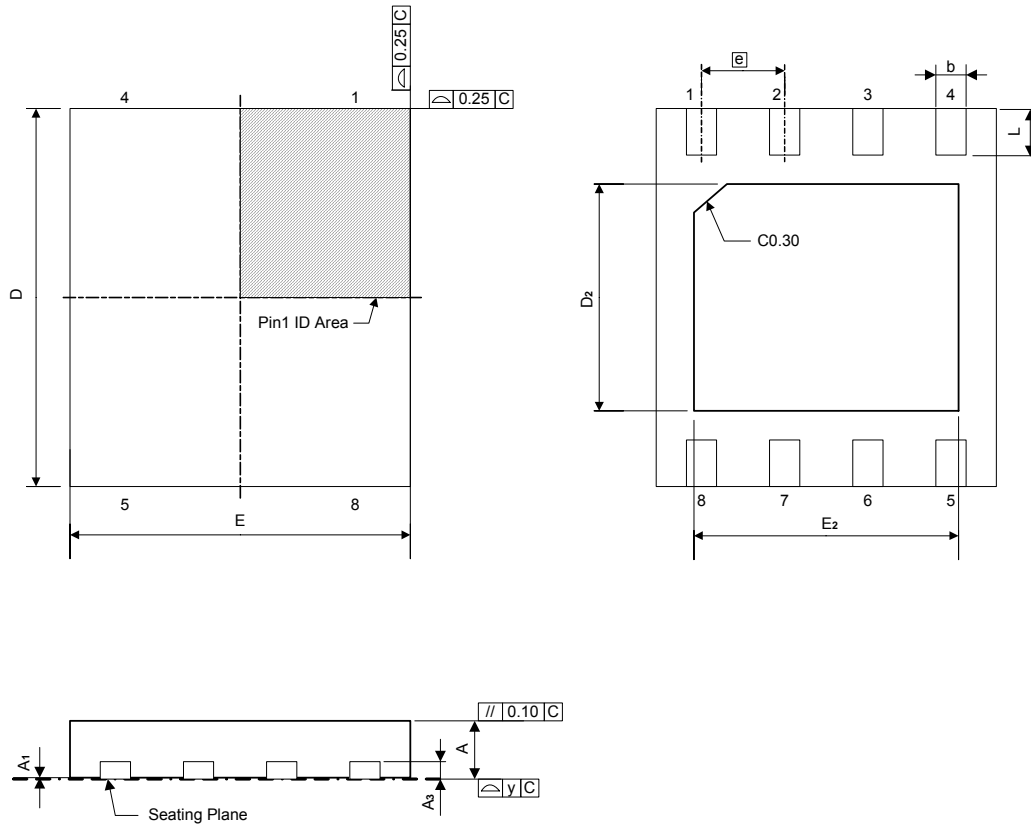

Symbol	Dimensions in mm			Dimensions in mil		
	Min	Nom	Max	Min	Nom	Max
A	0.700	0.750	0.800	27.6	29.5	31.5
A <sub>1</sub>	0.000	0.020	0.050	0.0	0.8	2.0
A <sub>3</sub>	0.203 REF			8.0 REF		
b	0.350	0.400	0.480	13.8	15.8	18.9
D	5.900	6.000	6.100	232.3	236.2	240.2
D <sub>2</sub>	3.200	3.400	3.600	126.0	133.9	141.7
E	4.900	5.000	5.100	192.9	196.9	200.8
E <sub>2</sub>	3.800	4.000	4.200	149.6	157.5	165.4
L	0.500	0.600	0.750	19.7	23.6	29.5
[e]	1.270 BSC			50.0 BSC		
y	0	-	0.080	0	-	3.2

**Note:**

1. Controlling dimension: millimeters
2. Leadframe thickness is 0.203mm (8mil)