

**DESCRIPTION**

The AA88347L is a CMOS processed digital to analog converter (DAC) with 8-bit resolution, low leakage and operating current. The AA88347L has 8 channels with built in operational amplifier output buffers which could operate in the full-swing voltage range from VCC to GND and enhance the Drive/Sink ability up to max. 1mA. Digital data (DI) input serially in a max. 2.5 MHz clock (CLK) rate. The latched 12-bit digital data is converted into an analog DC voltage in the range from VSS to VDD with 8-bit resolution in one of the 8 channels by the D/A converter in a max. 200 μ s settling time. AA88347L is a single 3V power DAC. Analog DC output could be full voltage swing as the analog power is equal to the system power. In addition to normal D/A converter applications, AA88347L is also available for electronic volume and instead of potentiometers for adjustment due to its high stability on the capacitive load. 16 pins TSSOP package type are available for AA88347L. Its operational temperature range is specified over -20°C to 85°C .

FEATURES

- 12 bits serial data input (3 wire serial data transfer method, DI, CLK, LD)
- R-2R resistor ladder used for D/A conversion
- 8 channels with 8-bit resolution monotonic D/A converter
- 8 channels buffer operational amplifiers operating in the full voltage range from VCC to GND only if VDD=VCC and VSS=GND
- Max. 2.5 MHz serial digital data input
- Serial I/O for cascade application
- Max. 1.0 mA output drive/sink current
- Two separate power supply/ground lines for system and analog power supply
- Single +3 V system power supply

APPLICATION

DVD, CD-R, CD-RW, DVC, digital camera, and other industrial equipments

■ BLOCK DIAGRAM

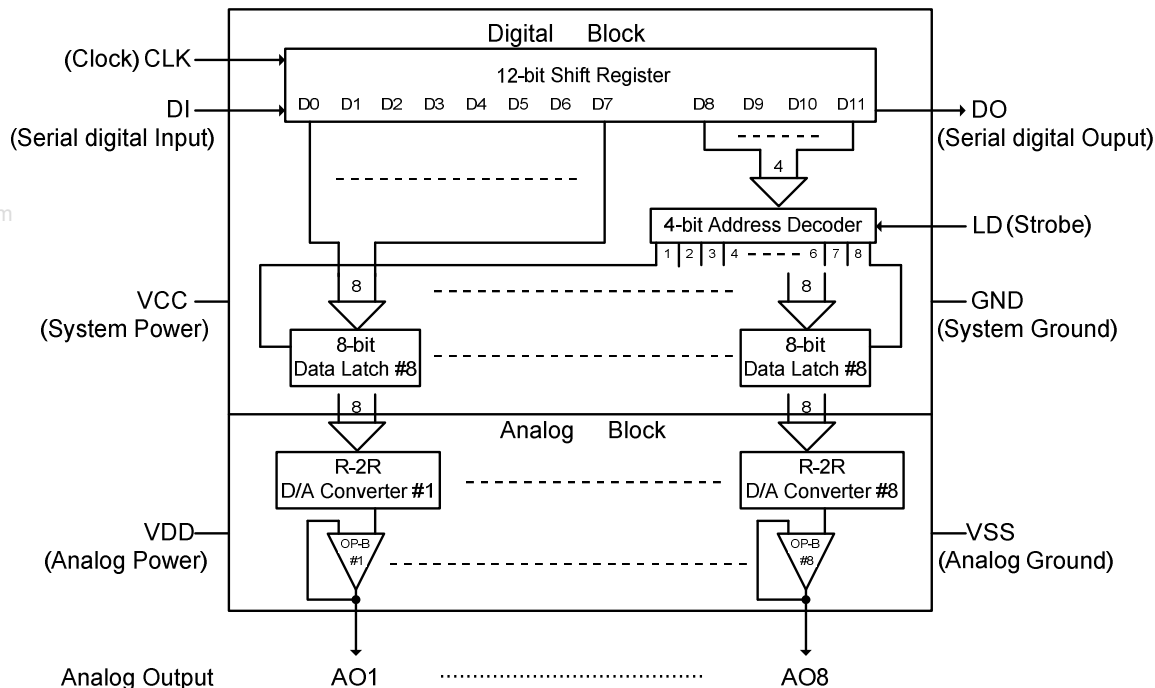

- * VCC and GND are for digital block and operational amplifier buffer block
- * VDD, VSS are only for Analog block except operational amplifier buffer block
- * $VSS + 2V \leq VDD \leq VCC$
- * $GND \leq VSS \leq VDD - 2V$

■ PIN DESCRIPTIONS

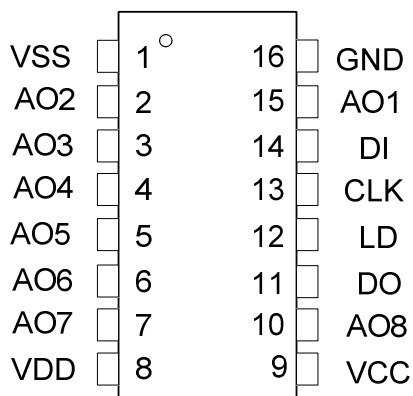

TOP VIEW

PIN NO.	PIN NAME	PIN FUNCTION
9	VCC	+3V system power supply pin
16	GND	System ground pin
8	VDD	Analog power supply pin
1	VSS	Analog ground pin
13	CLK	Serial clock input pin. At its rising edge, DI data shift into the Shift-Register.
12	LD	Data Strobe pin. When it's on high, upper 4-bit and lower 8-bit of the 12-bit in the Shift-Register be latched into the Address Decoder and the Data-Latch, respectively
Data Input/Output		
14	D1	Serial Digital Data input pin
11	DO	Serial Digital Data output pin. Output from the 12th data in the Shift-Register
DAC Output		
15	AO1	8-bit D/A converter outputs Output range is from VSS to VDD
2	AO2	
3	AO3	
4	AO4	
5	AO5	
6	AO6	
7	AO7	
10	AO8	

■ CASCADE CONNECTION

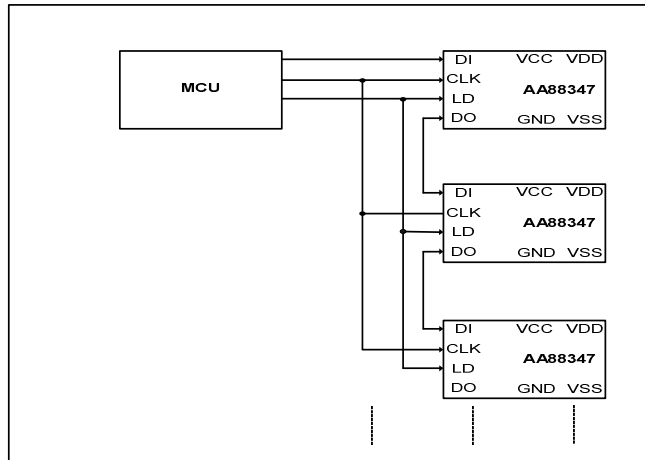

www.DataSheet4U.com

- VDD and VSS of each AA88347L could be different depend on the application consideration

■ DATA INPUT FORMAT

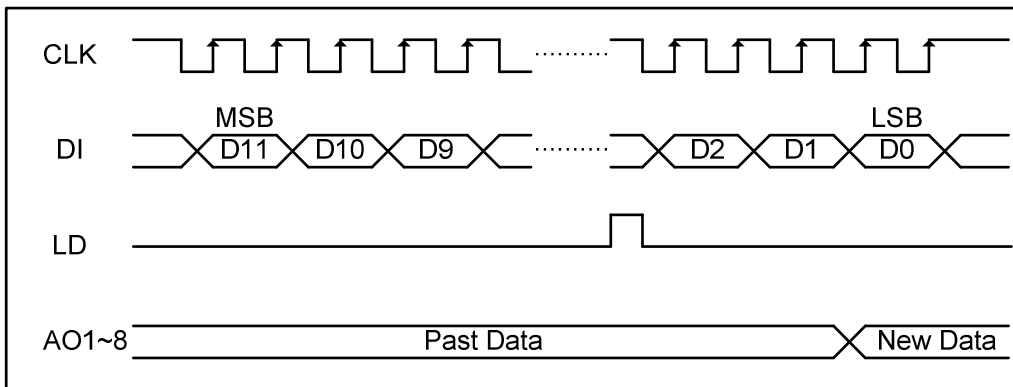

■ DATA FORMAT IN SHIFT REGISTER

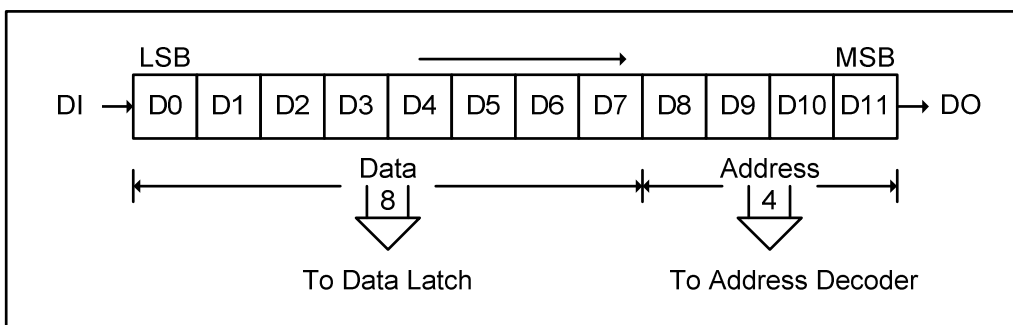

■ DATA CONVERSION



PRELIMINARY

8-BIT DAC

Data								DAC Output Level
D7	D6	D5	D4	D3	D2	D1	D0	AOX
0	0	0	0	0	0	0	0	VSS
0	0	0	0	0	0	0	1	VSS + LSB*
0	0	0	0	0	0	1	0	VSS + 2 * LSB
{	}	}	}	}	}	}	}	}
1	1	1	1	1	1	1	0	VDD - LSB
1	1	1	1	1	1	1	1	VDD

* LSB = (VDD-VSS)/255

CHANNEL MAP

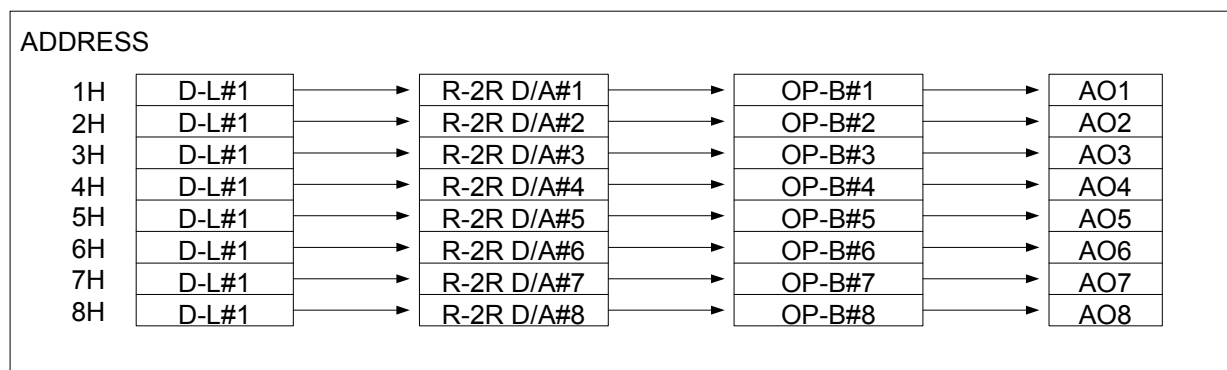

ADDRESS DECODING

ADDRESS				DATA LATCH SELECTED
D8	D9	D10	D11	
0	0	0	0	NA
0	0	0	1	Data Latch #1
0	0	1	0	Data Latch #2
0	0	1	1	Data Latch #3
0	1	0	0	Data Latch #4
0	1	0	1	Data Latch #5
0	1	1	0	Data Latch #6
0	1	1	1	Data Latch #7
1	0	0	0	Data Latch #8



PRELIMINARY

8-BIT DAC

1	0	0	1	NA
1	0	1	0	NA
1	0	1	1	NA
1	1	0	0	NA
1	1	0	1	NA
1	1	1	0	NA
1	1	1	1	NA

■ ABSOLUTE MAXIMUM RATINGS

TA=25°C, unless otherwise noted

PARAMETER	SYMBOL	RATING			UNIT
		MIN	TYP	MAX	
System Voltage	VCC	-0.3	—	+7.0	V
Analog Voltage	VDD	-0.3	—	+7.0	V
Input Voltage	VIN	-0.3	—	VCC + 0.3	V
Output Voltage	VOOUT	-0.3	—	VCC + 0.3	V
Power Dissipation	PD	—	—	250	mW
Operating Ambient Temperature	TA	-20	—	+85	°C
Storage Temperature	TS	-55	—	+150	°C

NOTE: Stress above those listed under “Absolute Maximum Rating” may cause permanent damage to the device. This is a stress rating only and functional operation of the device at these or any other conditions above those indicated in the operational section of this specification is not implied. Exposure to absolute maximum rating conditions for the extended periods of time may affect device reliability.

■ ELECTRICAL CHARACTERISTICS

◆ RECOMMENDED OPERATING CONDITIONS

SYMBOL	PARAMETER	CONDITIONS	LIMITS			UNIT
			MIN	TYP	MAX	



PRELIMINARY

8-BIT DAC

VCC	System Voltage	$VCC \geq VDD,$ $VDD - VSS \geq 2.0V$ $VSS \geq GND$	2.7	3.0	3.6	V	
GND			—	0	—	V	
VDD	Analog Voltage		2.0	—	VCC	V	
VSS			GND	—	VCC - 2.0	V	
IAO	Analog Output Current		VAO shift $\leq 0.3V$	-1.0	—	+1.0	mA
COL	Analog Output Load Capacitance for Oscillation limit			—	—	+1.0	μF
TA	Operating Ambient Temperature		-20	—	+85	$^{\circ}C$	

◆ DC CHARACTERISTICS

Digital Block

TA = 25 $^{\circ}C$

PARAMETER	SYMBOL	VALUE			UNIT	CONDITIONS
		MIN	TYP	MAX		
System Voltage	VCC	2.7	3.0	3.6	V	
System Current	ICC	—	1.0	3.0	mA	CLK = 1 MHz, No load;
Input Leakage Current	IILK	-5	—	+5	μA	VIN = 0V / 3V
Digital Input Low Voltage	VIL	—	—	0.2-VCC	V	
Digital Input High Voltage	VIH	0.8-VCC	—	—	V	
Digital Output Low	VOL	—	—	0.4	V	IOL = +2.5 mA
Digital Output High	VOH	VCC - 0.4	—	—	V	IOH = -400 μA

Analog Block

TA = 25 $^{\circ}C$

PARAMETER	SYMBOL	VALUE			UNIT	CONDITIONS
		MIN	TYP	MAX		
Analog Current	IDD	—	0.5	0.8	mA	No load
Analog Voltage	VDD	2.0	—	VCC	V	VDD - VSS \geq 2V
	VSS	GND	—	VCC - 2.0	V	
Analog Output Drive Range (VCC=VDD=3V,	VAOH	VDD - 0.1	VDD	VDD + 0.1	V	IAOH = 0 μA
	VAOH	VDD - 0.2	VDD	VDD + 0.2	V	IAOH = -500 μ

PRELIMINARY

8-BIT DAC

VSS=GND=0V, Data=#FF)	VAOH	VDD - 0.3	VDD	VDD + 0.3	V	IAOH = -1mA
Analog Output Sink Range (VCC=VDD=5V, VSS=GND=0V, Data=#00)	VAOL	VSS - 0.1	VSS	VSS + 0.1	V	IAOL = 0 μ A
	VAOL	VSS - 0.2	VSS	VSS + 0.2	V	IAOL = 500 μ A
	VAOL	VSS - 0.3	VSS	VSS + 0.3	V	IAOL = 1mA
Resolution (AOx)	RES	-	8	-	bit	VCC = 3.6V, GND=0V
Integral Non-Linearity	INL	-3.0	-	+3.0	LSB	VDD=3.36V, VSS=0.3
Differential Non-Linearity	DNL	-1.0	0	+2.0	LSB	LSB = 12mv, no load

NOTES: Integral Non-Linearity: The difference between the digital data converted DC analog values and a reference straight line drawn through the first and the last output values
 Differential Non-Linearity: The difference between the ideal and real increment value of DC analog voltage when the digital data increase 1 bit.

◆ **AC CHARACTERISTICS**

TA = 25°C

PARAMETER	SYMBOL	VALUE			UNIT	CONDITIONS
		MIN	TYP	MAX		
Clock Rate	TCR	400	1000	-	ns	
Load Strobe Pulse Width	TLDP	-	200	-	ns	
Analog Output Settling Time	TAOS	-	-	200	μ s	*RAL = 10 k Ω , CAL = 50pF (#00--> #FF)
Digital Output Delay	TDDO	-	-	170	ns	**CL = 100 pF (Max.)

AC TEST CONDITION

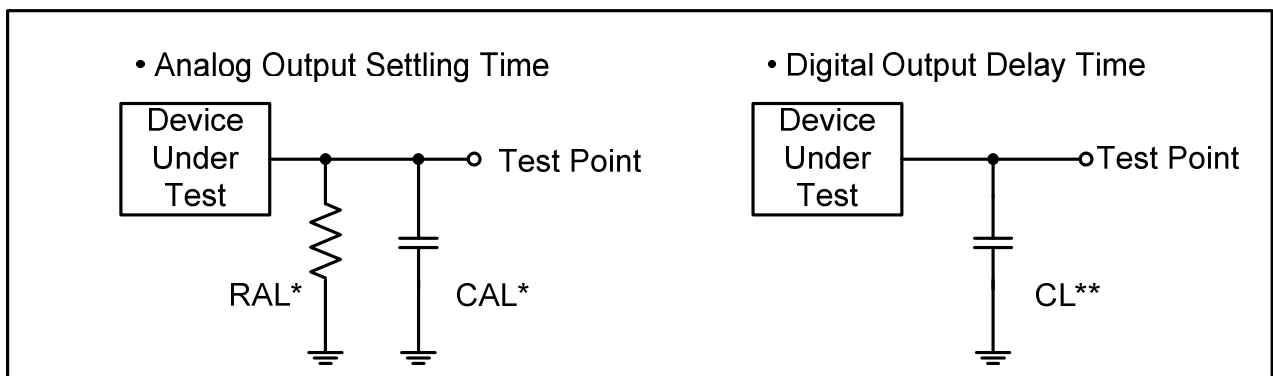



TIMING CHART

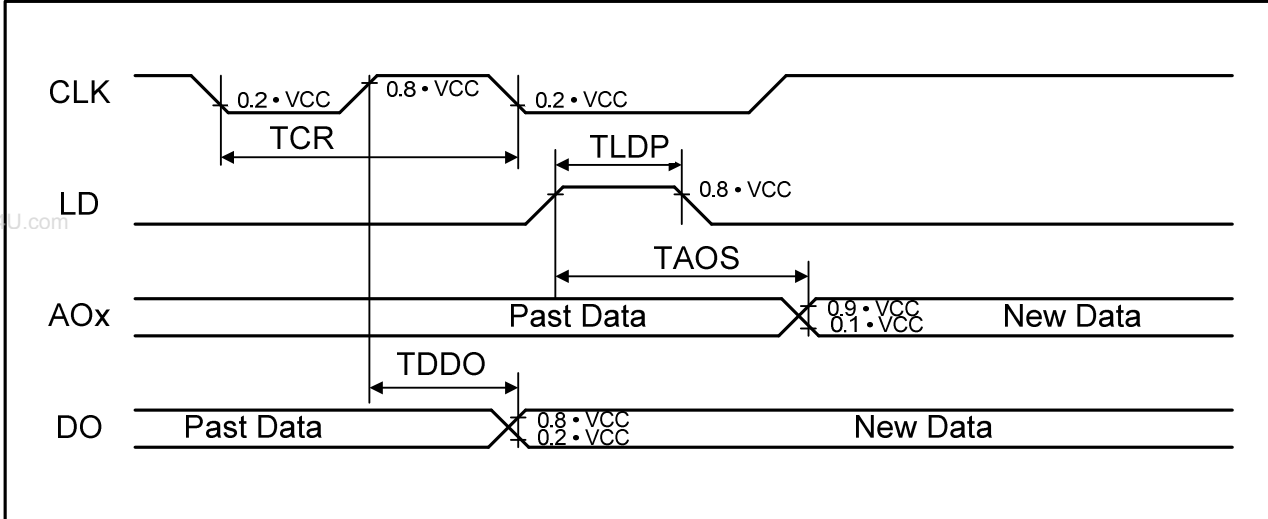

ORDERING INFORMATION

ORDER NO.	PACKAGE	PACKING	ONE REEL Q'TY	MARK CHART
AA88347L	TSSOP16L	Tape & Reel	2,500ea	

PACKAGE DIMENSIONS

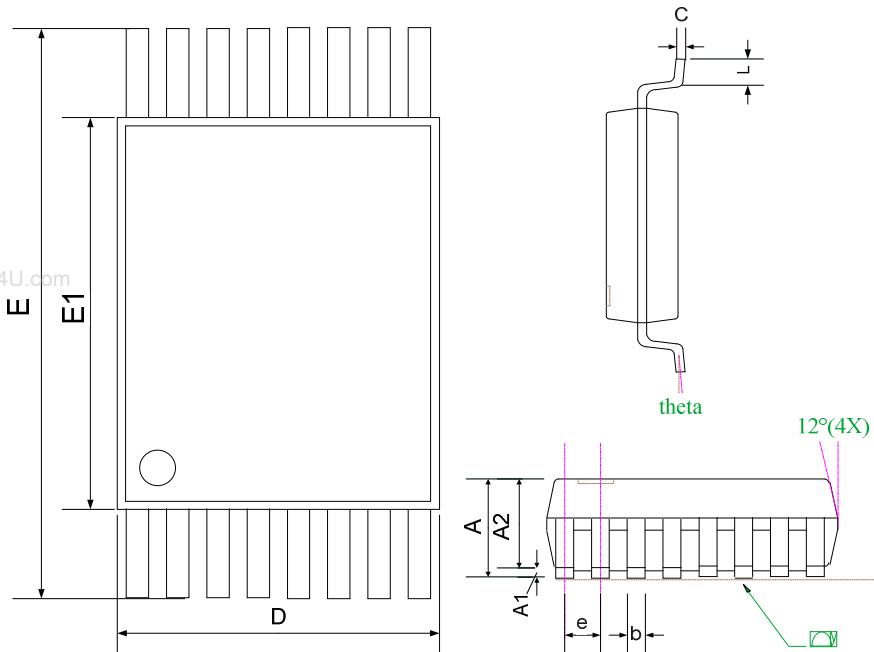

SYMBOLS	DIMENSIONS IN MILLIMETERS			DIMENSIONS IN INCHES		
	MIN	NOM	MAX	MIN	NOM	MAX
A	---	---	1.20	---	---	0.048
A1	0.05	---	0.15	0.002	---	0.006
A2	0.80	1.00	1.05	0.031	0.039	0.041
b	0.19	---	0.30	0.007	---	0.012
C	0.09	---	0.20	0.004	---	0.008
D	4.90	5.00	5.10	0.193	0.197	0.201
E	6.20	6.40	6.60	0.244	0.252	0.260
E1	4.30	4.40	4.50	0.169	0.173	0.177
e	---	0.65	---	---	0.026	---
L	0.45	0.60	0.75	0.018	0.024	0.030
y	---	---	0.10	---	---	0.004
theta	0°	---	8°	0°	---	8°

NOTE

1. PACKAGE BODY SIZES EXCLUDE MOLD FLASH PROTRUSIONS OR GATE BURRS
2. TOLERANCE +/- 0.1 mm UNLESS OTHERWISE SPECIFIED
3. COPLANARITY : 0.1 mm
4. CONTROLLING DIMENSION IS MILLIMETER. CONVERTED INCH DIMENSIONS ARE NOT NECESSARILY EXACT.
5. FOLLOWED FROM JEDEC MO-153