



Austin Semiconductor, Inc.

COTS PEM BOOT SECTOR FLASH AS29LV016

16 Megabit (2M x 8-Bit | 1M x 16-Bit) CMOS 3.0 Volt-Only Boot Sector Flash Memory

DISTINCTIVE CHARACTERISTICS

- **Commercial Off The Shelf, up-screened device**
- **Single power supply operation**
 - Full voltage range: 2.7 to 3.6 volt read and write operations for battery-powered applications
- **Manufactured on 200nm process technology**
- **Flexible sector architecture**
 - One 16 Kbyte, two 8 Kbyte, one 32 Kbyte, and thirty-one 64 Kbyte sectors (byte mode)
 - One 8 Kword, two 4 Kword, one 16 Kword, and thirty-one 32 Kword sectors (word mode)
- **Sector Protection features**
 - A hardware method of locking a sector to prevent any program or erase operations within that sector
 - Sectors can be locked in-system or via programming equipment
 - Temporary Sector Unprotect feature allows code changes in previously locked sectors
- **Unlock Bypass Program Command**
 - Reduces overall programming time when issuing multiple program command sequences
- **Top or bottom boot block configurations available**
- **Compatibility with JEDEC standards**
 - Pinout and software compatible with single-power supply Flash
 - Superior inadvertent write protection

PACKAGE OPTIONS

- **48-pin TSOP1**

PERFORMANCE CHARACTERISTICS

- **High performance**
 - Access times as fast as 70 ns @ Enhanced Temp [/ET]
 - Extended temp range available [/XT] (-55°C to +125°C)
- **Ultra low power consumption (typical values at 5 MHz)**
 - 200 nA Automatic Sleep mode current
 - 200 nA standby mode current
 - 9 mA read current
 - 20 mA program/erase current
- **Cycling endurance: 1,000,000 cycles per sector typical**
- **Data retention: 20 years typical**

SOFTWARE FEATURES

- **CFI (Common Flash Interface) compliant**
 - Provides device-specific information to the system, allowing host software to easily reconfigure for different Flash devices
- **Erase Suspend/Erase Resume**
 - Suspends an erase operation to read data from, or program data to, a sector that is not being erased, then resumes the erase operation
- **Data# Polling and toggle bits**
 - Provides a software method of detecting program or erase operation completion

HARDWARE FEATURES

- **Ready/Busy# pin (RY/BY#)**
 - Provides a hardware method of detecting program or erase cycle completion
- **Hardware reset pin (RESET#)**



Austin Semiconductor, Inc.

COTS PEM BOOT SECTOR FLASH AS29LV016

GENERAL DESCRIPTION

The AS29LV016 is a 16 Mbit, 3.0 Volt-only Flash memory organized as 2,097,152 bytes or 1,048,576 words. The word-wide data (x16) appears on DQ15–DQ0; the byte-wide (x8) data appears on DQ7–DQ0. This device is designed to be programmed in-system with the standard system 3.0 volt V_{CC} supply. A 12.0 V V_{PP} or 5.0 V_{CC} are not required for write or erase operations. The device can also be programmed in standard EPROM programmers.

The device offers access times of 70 ns, 90 ns and 100 ns allowing high speed microprocessors to operate without wait states. To eliminate bus contention the device has separate chip enable (CE#), write enable (WE#) and output enable (OE#) controls.

The device requires only a **single 3.0 volt power supply** for both read and write functions. Internally generated and regulated voltages are provided for the program and erase operations.

The AS29LV016 is entirely command set compatible with the **JEDEC single-power-supply Flash standard**. Commands are written to the command register using standard microprocessor write timings. Register contents serve as input to an internal state-machine that controls the erase and programming circuitry. Write cycles also internally latch addresses and data needed for the programming and erase operations. Reading data out of the device is similar to reading from other Flash or EPROM devices.

Device programming occurs by executing the program command sequence. This initiates the **Embedded Program** algorithm—an internal algorithm that automatically times the program pulse widths and verifies proper cell margin. The **Unlock Bypass** mode facilitates faster programming times by requiring only two write cycles to program data instead of four.

Device erasure occurs by executing the erase command sequence. This initiates the **Embedded Erase** algorithm—an internal algorithm that automatically preprograms the array (if it is not

already programmed) before executing the erase operation. During erase, the device automatically times the erase pulse widths and verifies proper cell margin.

The host system can detect whether a program or erase operation is complete by observing the RY/BY# pin, or by reading the DQ7 (Data# Polling) and DQ6 (toggle) **status bits**. After a program or erase cycle has been completed, the device is ready to read array data or accept another command.

The **sector erase architecture** allows memory sectors to be erased and reprogrammed without affecting the data contents of other sectors. The device is fully erased when shipped from the factory.

Hardware data protection measures include a low V_{CC} detector that automatically inhibits write operations during power transitions. The **hardware sector protection** feature disables both program and erase operations in any combination of the sectors of memory. This can be achieved in-system or via programming equipment.

The **Erase Suspend/Erase Resume** feature enables the user to put erase on hold for any period of time to read data from, or program data to, any sector that is not selected for erasure. True background erase can thus be achieved.

The **hardware RESET# pin** terminates any operation in progress and resets the internal state machine to reading array data. The RESET# pin may be tied to the system reset circuitry. A system reset would thus also reset the device, enabling the system microprocessor to read the boot-up firmware from the Flash memory.

The device offers two power-saving features. When addresses have been stable for a specified amount of time, the device enters the **automatic sleep mode**. The system can also place the device into the **standby mode**. Power consumption is greatly reduced in both these modes.



Austin Semiconductor, Inc.

**COTS PEM
BOOT SECTOR FLASH
AS29LV016**

PRODUCT SELECTOR GUIDE

Family Part Number		AS29LV016		
Speed Option	Voltage Range: V _{CC} = 2.7-3.6V	70	90	100
Max access time, ns (t _{ACC})		70	90	100
Max CE# access time, ns (t _{CE})		70	90	100
Max OE# access time, ns (t _{OE})		30	35	40

Note: See AC Characteristics on page 29 for full specifications

BLOCK DIAGRAM

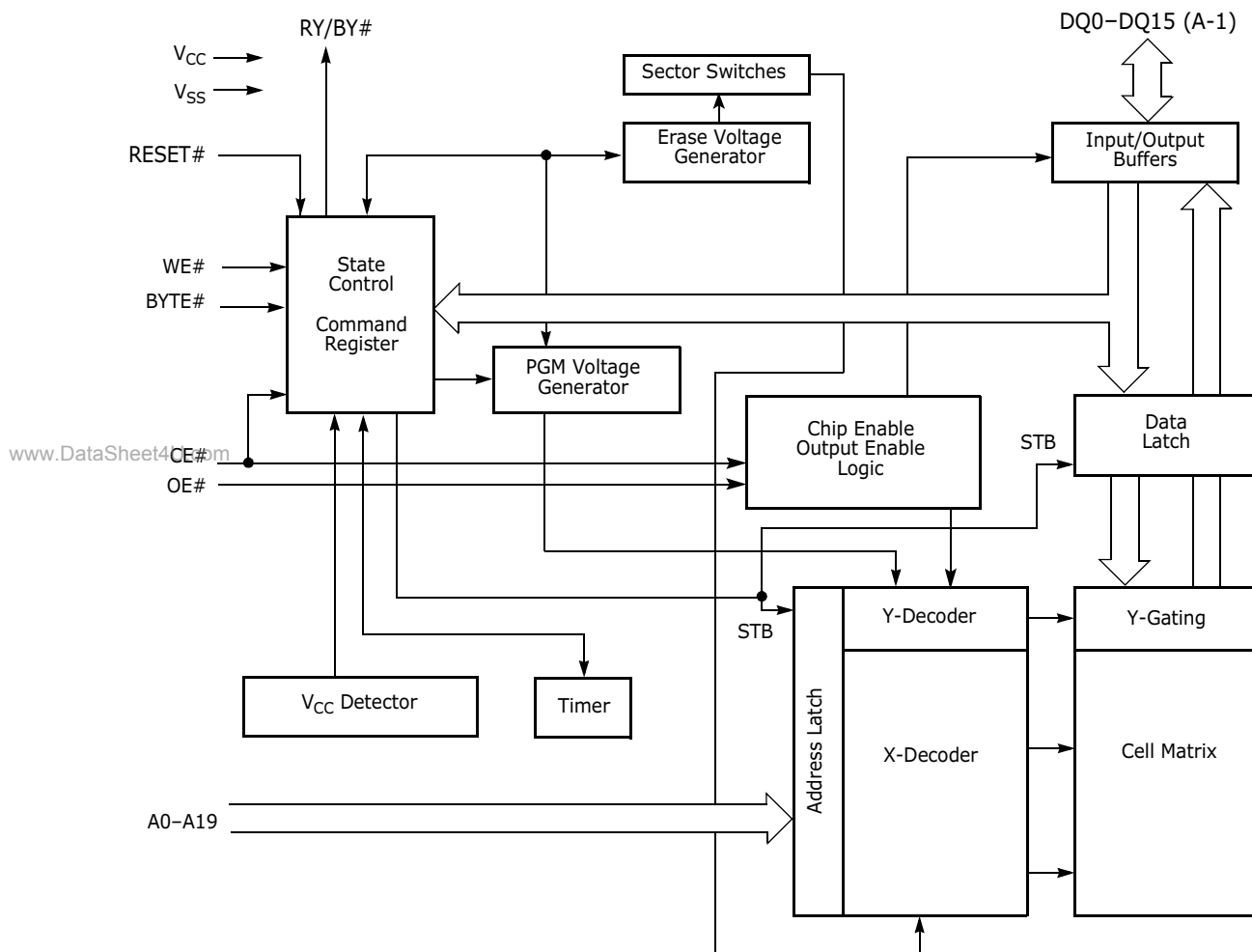



Austin Semiconductor, Inc.

**COTS PEM
BOOT SECTOR FLASH
AS29LV016**

PIN CONFIGURATION

- A0–A19 = 20 addresses
- DQ0–DQ14 = 15 data inputs/outputs
- DQ15/A-1 = DQ15 (data input/output, word mode),
A-1 (LSB address input, byte mode)
- BYTE# = Selects 8-bit or 16-bit mode
- CE# = Chip enable
- OE# = Output enable
- WE# = Write enable
- RESET# = Hardware reset pin
- RY/BY# = Ready/Busy output
- V_{CC} = 3.0 volt-only single power supply (see
Product Selector Guide for speed
options and voltage supply tolerances)
- V_{SS} = Device ground
- NC = Pin not connected internally

LOGIC SYMBOL

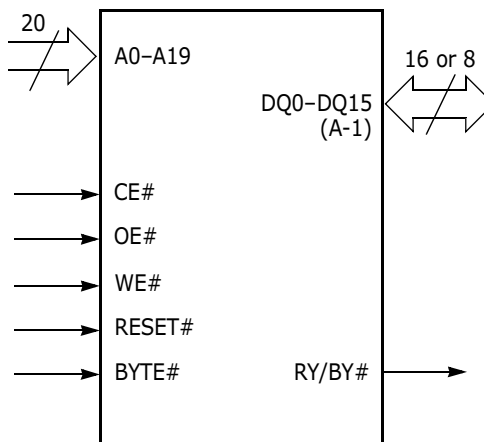

CONNECTION DIAGRAMS

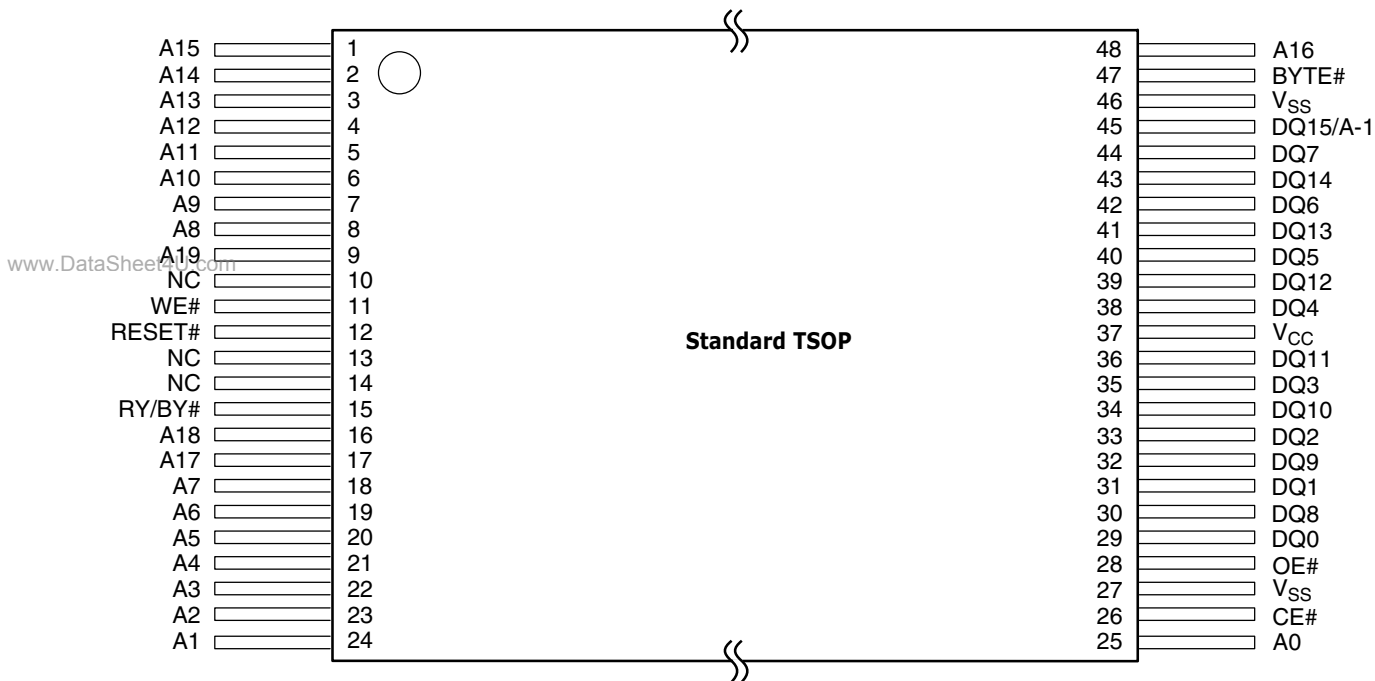



Austin Semiconductor, Inc.

COTS PEM
BOOT SECTOR FLASH
AS29LV016

ORDERING INFORMATION

AS29LV016TRG-70/ET	TOP BOOT	TSOP1-48	ENHANCED
AS29LV016BRG-70/ET	BOTTOM BOOT	TSOP1-48	ENHANCED
AS29LV016TRG-90/ET	TOP BOOT	TSOP1-48	ENHANCED
AS29LV016BRG-90/ET	BOTTOM BOOT	TSOP1-48	ENHANCED
AS29LV016TRG-90/XT	TOP BOOT	TSOP1-48	EXTENDED
AS29LV016BRG-90/XT	BOTTOM BOOT	TSOP1-48	EXTENDED
AS29LV016TRG-100/ET	TOP BOOT	TSOP1-48	ENHANCED
AS29LV016BRG-100/ET	BOTTOM BOOT	TSOP1-48	ENHANCED
AS29LV016TRG-100/XT	TOP BOOT	TSOP1-48	EXTENDED
AS29LV016BRG-100/XT	BOTTOM BOOT	TSOP1-48	EXTENDED

PB-FREE OPTION (WHERE AVAILABLE)

AS29LV016TRGR-70/ET	TOP BOOT	TSOP1-48	ENHANCED
AS29LV016TRGR-70/ET	BOTTOM BOOT	TSOP1-48	ENHANCED

TAPE / REEL OPTION (WHERE AVAILABLE)

.14-14" Reel (32mm TAPE)

.7-7" Reel (32mm TAPE)



Austin Semiconductor, Inc.

COTS PEM BOOT SECTOR FLASH AS29LV016

DEVICE BUS OPERATIONS

This section describes the requirements and use of the device bus operations, which are initiated through the internal command register. The command register itself does not occupy any addressable memory location. The register is composed of latches that store the commands, along with the address and data information needed to execute the command. The contents of the register serve as inputs to the internal state machine. The state machine outputs dictate the function of the device. Table 1 lists the device bus operations, the inputs and control levels they require, and the resulting output. The following subsections describe each of these operations in further detail.

Table 1: AS29LV016 Device Bus Operations

Operation	CE#	OE#	WE#	RESET#	Address ¹	DQ0-DQ7	DQ8-DQ15	
							BYTE#	BYTE#
							=V _{IH}	=V _{IL}
Read	L	L	H	H	A _{IN}	D _{OUT}	D _{OUT}	DQ8-DQ14= High Z, DQ15=A-1
Write	L	H	L	H	A _{IN}	D _{IN}	D _{IN}	
Standby	V _{CC} ± 0.3V	X	X	V _{CC} ± 0.3V	X	High-Z	High-Z	High-Z
Output Disable	L	H	H	H	X	High-Z	High-Z	High-Z
Reset	X	X	X	L	X	High-Z	High-Z	High-Z
Sector Protect ²	L	H	L	V _{ID}	Sector Address, A6=L, A1=H, A0=L	D _{IN}	X	X
Sector Unprotect ²	L	H	L	V _{ID}	Sector Address, A6=H, A1=H, A0=L	D _{IN}	X	X
Temporary Sector Unprotect	X	X	X	V _{ID}	A _{IN}	D _{IN}	D _{IN}	High-Z

Legend:

L= Logic Low = V_{IL}, H=Logic High=V_{IH}, V_{ID}=12.0±0.5V, X=Don't Care, A_{IN}=Address In, D_{IN}=Data In, D_{OUT}=Data Out

Notes:

1. Addresses are A19:A0 in word mode (BYTE# = V_{IH}), A19:A-1 in byte mode (BYTE# = V_{IL})
2. The sector protect and sector unprotect functions may also be implemented via programming equipment. See Sector Protection / Unprotection on page 11.

WORD / BYTE CONFIGURATION

The BYTE# pin controls whether the device data I/O pins DQ15–DQ0 operate in the byte or word configuration. If the BYTE# pin is set at logic 1, the device is in word configuration, DQ15–DQ0 are active and controlled by CE# and OE#.

If the BYTE# pin is set at logic 0, the device is in byte configuration, and only data I/O pins DQ0–DQ7 are active and controlled by CE# and OE#. The data I/O pins DQ8–DQ14 are tri-stated, and the DQ15 pin is used as an input for the LSB (A-1) address function.



Austin Semiconductor, Inc.

COTS PEM BOOT SECTOR FLASH AS29LV016

REQUIREMENTS FOR READING ARRAY DATA

To read array data from the outputs, the system must drive the CE# and OE# pins to V_{IL} . CE# is the power control and selects the device. OE# is the output control and gates array data to the output pins. WE# should remain at V_{IH} . The BYTE# pin determines whether the device outputs array data in words or bytes.

The internal state machine is set for reading array data upon device power-up, or after a hardware reset. This ensures that no spurious alteration of the memory content occurs during the power transition. No command is necessary in this mode to obtain array data. Standard microprocessor read cycles that assert valid addresses on the device address inputs produce valid data on the device data outputs. The device remains enabled for read access until the command register contents are altered.

See Reading Array Data on page 17 for more information. Refer to the AC Read Operations on page 29 for timing specifications and to Figure 12, on page 29 for the timing diagram. I_{CC1} in the DC Characteristics table represents the active current specification for reading array data.

WRITING COMMANDS / COMMAND SEQUENCES

To write a command or command sequence (which includes programming data to the device and erasing sectors of memory), the system must drive WE# and CE# to V_{IL} , and OE# to V_{IH} .

For program operations, the BYTE# pin determines whether the device accepts program data in bytes or words. See Word Byte Configuration on page 6 for more information.

The device features an **Unlock Bypass** mode to facilitate faster programming. Once the device enters the Unlock Bypass mode, only two write cycles are required to program a word or byte, instead of four. Word Byte Program Command Sequence on page 18 has details on programming data to the device using both standard and Unlock Bypass command sequences.

An erase operation can erase one sector, multiple sectors, or the entire device. Table 2 on page 9 and Table 3 on page 10 indicate the address space that each sector occupies. A “sector address” consists of the address bits required to uniquely select a sector. The Command Definitions on page 17 has details on erasing a sector or the entire chip, or suspending/resuming the erase operation.

After the system writes the autoselect command sequence, the device enters the autoselect mode. The system can then read autoselect codes from the internal register (which is separate from the memory array) on DQ7–DQ0. Standard read cycle timings apply in this mode. Refer to Autoselect Mode on page 11 and Autoselect Command Sequence on page 17 for more information.

I_{CC2} in the DC Characteristics table represents the active current specification for the write mode. AC Characteristics on page 29 contains timing specification tables and timing diagrams for write operations.

PROGRAM AND ERASE OPERATION STATUS

During an erase or program operation, the system may check the status of the operation by reading the status bits on DQ7–DQ0. Standard read cycle timings and I_{CC} read specifications apply. Refer to Write Operation Status on page 22 for more information, and to AC Characteristics on page 29 for timing diagrams.



Austin Semiconductor, Inc.

COTS PEM BOOT SECTOR FLASH AS29LV016

STANDBY MODE

When the system is not reading or writing to the device, it can place the device in the standby mode. In this mode, current consumption is greatly reduced, and the outputs are placed in the high impedance state, independent of the OE# input.

The device enters the CMOS standby mode when the CE# and RESET# pins are both held at $V_{CC} \pm 0.3$ V. (Note that this is a more restricted voltage range than V_{IH} .) If CE# and RESET# are held at V_{IH} , but not within $V_{CC} \pm 0.3$ V, the device will be in the standby mode, but the standby current will be greater. The device requires standard access time (t_{CE}) for read access when the device is in either of these standby modes, before it is ready to read data.

If the device is deselected during erasure or programming, the device draws active current until the operation is completed.

I_{CC3} and I_{CC4} represents the standby current specification shown in the table in DC Characteristics on page 27.

AUTOMATIC SLEEP MODE

The automatic sleep mode minimizes Flash device energy consumption. The device automatically enables this mode when addresses remain stable for $t_{ACC} + 30$ ns. The automatic sleep mode is independent of the CE#, WE#, and OE# control signals. Standard address access timings provide new data when addresses are changed. While in sleep mode, output data is latched and always available to the system. I_{CC4} in the DC Characteristics on page 27 represents the automatic sleep mode current specification.

RESET#: HARDWARE RESET PIN

The RESET# pin provides a hardware method of resetting the device to reading array data. When the system drives the RESET# pin to V_{IL} for at least a period of t_{RP} , the device **immediately terminates** any operation in progress, tristates all data output pins, and ignores all read/write attempts for the duration of the RESET# pulse. The device also resets the internal state machine to reading array data. The operation that was interrupted should be reinitiated once the device is ready to accept another command sequence, to ensure data integrity.

Current is reduced for the duration of the RESET# pulse. When RESET# is held at $V_{SS} \pm 0.3$ V, the device draws CMOS standby current (I_{CC4}). If RESET# is held at V_{IL} but not within $V_{SS} \pm 0.3$ V, the standby current will be greater.

The RESET# pin may be tied to the system reset circuitry. A system reset would thus also reset the Flash memory, enabling the system to read the boot-up firmware from the Flash memory.

If RESET# is asserted during a program or erase operation, the RY/BY# pin remains a 0 (busy) until the internal reset operation is complete, which requires a time of t_{READY} (during Embedded Algorithms). The system can thus monitor RY/BY# to determine whether the reset operation is complete. If RESET# is asserted when a program or erase operation is not executing (RY/BY# pin is 1), the reset operation is completed within a time of t_{READY} (not during Embedded Algorithms). The system can read data t_{RH} after the RESET# pin returns to V_{IH} . Refer to the tables in AC Characteristics on page 29 for RESET# parameters and to Figure 13, on page 30 for the timing diagram.



Austin Semiconductor, Inc.

COTS PEM BOOT SECTOR FLASH AS29LV016

OUTPUT DISABLE MODE

When the OE# input is at V_{IH} , output from the device is disabled. The output pins are placed in the high impedance state.

Table 2: Sector Address Tables (Top Boot Device)

Sector	A19	A18	A17	A16	A15	A14	A13	A12	Sector Size (Kbytes / Kwords)	Address Range (in hexadecimal)	
										Byte Mode (x8)	Word Mode (x16)
SA0	0	0	0	0	0	X	X	X	64/32	000000-00FFFF	00000-07FFF
SA1	0	0	0	0	1	X	X	X	64/32	010000-01FFFF	08000-0FFFF
SA2	0	0	0	1	0	X	X	X	64/32	020000-02FFFF	10000-17FFF
SA3	0	0	0	1	1	X	X	X	64/32	030000-03FFFF	18000-1FFFF
SA4	0	0	1	0	0	X	X	X	64/32	040000-04FFFF	20000-27FFF
SA5	0	0	1	0	1	X	X	X	64/32	050000-05FFFF	28000-2FFFF
SA6	0	0	1	1	0	X	X	X	64/32	060000-06FFFF	30000-37FFF
SA7	0	0	1	1	1	X	X	X	64/32	070000-07FFFF	38000-3FFFF
SA8	0	1	0	0	0	X	X	X	64/32	080000-08FFFF	40000-47FFF
SA9	0	1	0	0	1	X	X	X	64/32	090000-09FFFF	48000-4FFFF
SA10	0	1	0	1	0	X	X	X	64/32	0A0000-0AFFFF	50000-57FFF
SA11	0	1	0	1	1	X	X	X	64/32	0B0000-0BFFFF	58000-5FFFF
SA12	0	1	1	0	0	X	X	X	64/32	0C0000-0CFFFF	60000-67FFF
SA13	0	1	1	0	1	X	X	X	64/32	0D0000-0DFFFF	68000-6FFFF
SA14	0	1	1	1	0	X	X	X	64/32	0E0000-0EFFFF	70000-77FFF
SA15	0	1	1	1	1	X	X	X	64/32	0F0000-0FFFFF	78000-7FFFF
SA16	1	0	0	0	0	X	X	X	64/32	100000-10FFFF	80000-87FFF
SA17	1	0	0	0	1	X	X	X	64/32	110000-11FFFF	88000-8FFFF
SA18	1	0	0	1	0	X	X	X	64/32	120000-12FFFF	90000-97FFF
SA19	1	0	0	1	1	X	X	X	64/32	130000-13FFFF	98000-9FFFF
SA20	1	0	1	0	0	X	X	X	64/32	140000-14FFFF	A0000-A7FFF
SA21	1	0	1	0	1	X	X	X	64/32	150000-15FFFF	A8000-AFFFF
SA22	1	0	1	1	0	X	X	X	64/32	160000-16FFFF	B0000-B7FFF
SA23	1	0	1	1	1	X	X	X	64/32	170000-17FFFF	B8000-BFFFF
SA24	1	1	0	0	0	X	X	X	64/32	180000-18FFFF	C0000-C7FFF
SA25	1	1	0	0	1	X	X	X	64/32	190000-19FFFF	C8000-CFFFF
SA26	1	1	0	1	0	X	X	X	64/32	1A0000-1AFFFF	D0000-D7FFF
SA27	1	1	0	1	1	X	X	X	64/32	1B0000-1BFFFF	D8000-DFFFF
SA28	1	1	1	0	0	X	X	X	64/32	1C0000-1CFFFF	E0000-E7FFF
SA29	1	1	1	0	1	X	X	X	64/32	1D0000-1DFFFF	E8000-EFFFF
SA30	1	1	1	1	0	X	X	X	64/32	1E0000-1EFFFF	F0000-F7FFF
SA31	1	1	1	1	1	0	X	X	32/16	1F0000-1F7FFF	F8000-FBFFF
SA32	1	1	1	1	1	1	0	0	8/4	1F8000-1F9FFF	FC000-FCFFF
SA33	1	1	1	1	1	1	0	1	8/4	1FA000-1FBFFF	FD000-FDFFF
SA34	1	1	1	1	1	1	1	X	16/8	1FC000-1FFFFF	FE000-FFFFF

Note: Address range is A19:A-1 in byte mode and A19:A0 in word mode. See Word/Byte Configuration on page 6.



Austin Semiconductor, Inc.

COTS PEM BOOT SECTOR FLASH AS29LV016

Table 3: Sector Address Tables (Bottom Boot Device)

Sector	A19	A18	A17	A16	A15	A14	A13	A12	Sector Size (Kbytes / Kwords)	Address Range (in hexadecimal)		
										Byte Mode (x8)	Word Mode (x16)	
SA0	0	0	0	0	0	0	0	X	16/8	000000-003FFF	00000-01FFF	
SA1	0	0	0	0	0	0	0	1	0	8/4	004000-005FFF	02000-02FFF
SA2	0	0	0	0	0	0	0	1	1	8/4	006000-007FFF	03000-03FFF
SA3	0	0	0	0	0	0	1	X	X	32/16	008000-00FFFF	04000-04FFF
SA4	0	0	0	0	1	0	X	X	X	64/32	010000-01FFFF	08000-0FFFF
SA5	0	0	0	0	1	0	X	X	X	64/32	020000-02FFFF	10000-17FFF
SA6	0	0	0	0	1	1	X	X	X	64/32	030000-03FFFF	18000-1FFFF
SA7	0	0	1	0	0	0	X	X	X	64/32	040000-04FFFF	20000-27FFF
SA8	0	0	1	0	1	0	X	X	X	64/32	050000-05FFFF	28000-2FFFF
SA9	0	0	1	1	0	0	X	X	X	64/32	060000-06FFFF	30000-37FFF
SA10	0	0	1	1	1	0	X	X	X	64/32	070000-07FFFF	38000-3FFFF
SA11	0	1	0	0	0	0	X	X	X	64/32	080000-08FFFF	40000-47FFF
SA12	0	1	0	0	1	0	X	X	X	64/32	090000-09FFFF	48000-4FFFF
SA13	0	1	0	1	0	0	X	X	X	64/32	0A0000-0AFFFF	50000-57FFF
SA14	0	1	0	1	1	0	X	X	X	64/32	0B0000-0BFFFF	58000-5FFFF
SA15	0	1	1	0	0	0	X	X	X	64/32	0C0000-0CFFFF	60000-67FFF
SA16	0	1	1	0	1	0	X	X	X	64/32	0D0000-0DFFFF	68000-6FFFF
SA17	0	1	1	1	0	0	X	X	X	64/32	0E0000-0EFFFF	70000-77FFF
SA18	0	1	1	1	1	0	X	X	X	64/32	0F0000-0FFFFF	78000-7FFFF
SA19	1	0	0	0	0	0	X	X	X	64/32	100000-10FFFF	80000-87FFF
SA20	1	0	0	0	1	0	X	X	X	64/32	110000-11FFFF	88000-8FFFF
SA21	1	0	0	1	0	0	X	X	X	64/32	120000-12FFFF	90000-97FFF
SA22	1	0	0	1	1	0	X	X	X	64/32	130000-13FFFF	98000-9FFFF
SA23	1	0	1	0	0	0	X	X	X	64/32	140000-14FFFF	A0000-A7FFF
SA24	1	0	1	0	1	0	X	X	X	64/32	150000-15FFFF	A8000-AFFFF
SA25	1	0	1	1	0	0	X	X	X	64/32	160000-16FFFF	B0000-B7FFF
SA26	1	0	1	1	1	0	X	X	X	64/32	170000-17FFFF	B8000-BFFFF
SA27	1	1	0	0	0	0	X	X	X	64/32	180000-18FFFF	C0000-C7FFF
SA28	1	1	0	0	1	0	X	X	X	64/32	190000-19FFFF	C8000-CFFFF
SA29	1	1	0	1	0	0	X	X	X	64/32	1A0000-1AFFFF	D0000-D7FFF
SA30	1	1	0	1	1	0	X	X	X	64/32	1B0000-1BFFFF	D8000-DFFFF
SA31	1	1	1	0	0	0	X	X	X	64/32	1C0000-1CFFFF	E0000-E7FFF
SA32	1	1	1	0	1	0	X	X	X	64/32	1D0000-1DFFFF	E8000-EFFFF
SA33	1	1	1	1	0	0	X	X	X	64/32	1E0000-1EFFFF	F0000-F7FFF
SA34	1	1	1	1	1	0	X	X	X	64/32	1F0000-1FFFFF	F8000-FFFFF

Note: Address range is A19:A-1 in byte mode and A19:A0 in word mode. See Word/Byte Configuration on page 6.



Austin Semiconductor, Inc.

COTS PEM BOOT SECTOR FLASH AS29LV016

AUTOSELECT MODE

The autoselect mode provides manufacturer and device identification, and sector protection verification, through identifier codes output on DQ7–DQ0. This mode is primarily intended for programming equipment to automatically match a device to be programmed with its corresponding programming algorithm. However, the autoselect codes can also be accessed in-system through the command register.

When using programming equipment, the autoselect mode requires V_{ID} (11.5 V to 12.5 V) on address pin A9. Address pins A6, A1, and A0 must be as shown in Table 4 below.

In addition, when verifying sector protection, the sector address must appear on the appropriate highest order address bits (see Table 2 on page 9 and Table 3 on page 10). Table 4, immediately below, shows the remaining address bits that are don't care. When all necessary bits have been set as required, the programming equipment may then read the corresponding identifier code on DQ7-DQ0.

To access the autoselect codes in-system, the host system can issue the autoselect command via the command register, as shown in Table 9 on page 21. This method does not require VID. See Command Definitions on page 17 for details on using the autoselect mode.

Table 4: AS29LV016 Autoselect Codes (High Voltage Method)

Description	Mode	CE#	OE#	WE#	A19 to A12	A11 to A10	A9	A8 to A7	A6	A5 to A4	A3 to A2	A1	A0	DQ8 to DQ15	DQ7 to DQ0
Manufacturer ID: Spansion		L	L	H	X	X	V_{ID}	X	L	X	L	L	L	X	01h
Device ID: S29AL016D (Top Boot Block)	Word	L	L	H	X	X	V_{ID}	X	L	X	L	L	H	22h	C4h
	Byte	L	L	H	X	X	V_{ID}	X	L	X	L	L	H	X	C4h
Device ID: S29AL016D (Bottom Boot Block)	Word	L	L	H	X	X	V_{ID}	X	L	X	L	L	H	22h	49h
	Byte	L	L	H	X	X	V_{ID}	X	L	X	L	L	H	X	49h
Sector Protection Verification		L	L	H	SA	X	V_{ID}	X	L	X	L	H	L	X	01h (protected)
														X	00h (unprotected)

L = Logic Low = V_{IL} , H = Logic High = V_{IH} , SA = Sector Address, X = Don't Care

Note: The autoselect codes may also be accessed in-system via command sequences. See Table 9 on page 21.

SECTOR PROTECTION / UNPROTECTION

The hardware sector protection feature disables both program and erase operations in any sector. The hardware sector unprotection feature re-enables both program and erase operations in previously protected sectors.

The device is shipped with all sectors unprotected.

It is possible to determine whether a sector is protected or unprotected. See Autoselect Mode above for details.

Sector protection/unprotection can be implemented via two methods.

The primary method requires V_{ID} on the RESET# pin only, and can be implemented either in-system or via programming equipment. Figure 2, on page 13 shows the algorithms and Figure 22, on page 36 shows the timing diagram. This method uses standard microprocessor bus cycle timing. For sector unprotect, all unprotected sectors must first be protected prior to the first sector unprotect write cycle.

The alternate method intended only for programming equipment requires V_{ID} on address pin A9 and OE#.



Austin Semiconductor, Inc.

COTS PEM
BOOT SECTOR FLASH
AS29LV016

TEMPORARY SECTOR UNPROTECT

This feature allows temporary unprotection of previously protected sectors to change data in-system. The Sector Unprotect mode is activated by setting the RESET# pin to V_{ID} . During this mode, formerly protected sectors can be programmed or erased by selecting the sector addresses. Once V_{ID} is removed from the RESET# pin, all the previously protected sectors are protected again. Figure 1 shows the algorithm, and Figure 21, on page 35 shows the timing diagrams, for this feature.

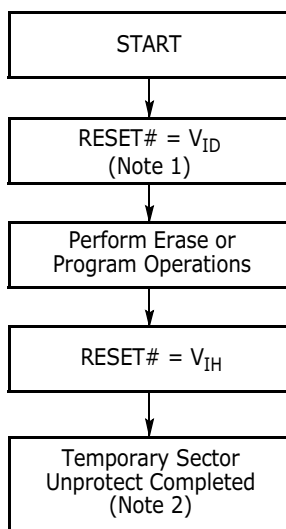

Notes:

1. All protected sectors unprotected.
2. All previously protected sectors are protected once again.

www.DataSheet4U.com

Figure 1. Temporary Sector Unprotect Operation



Austin Semiconductor, Inc.

**COTS PEM
BOOT SECTOR FLASH
AS29LV016**

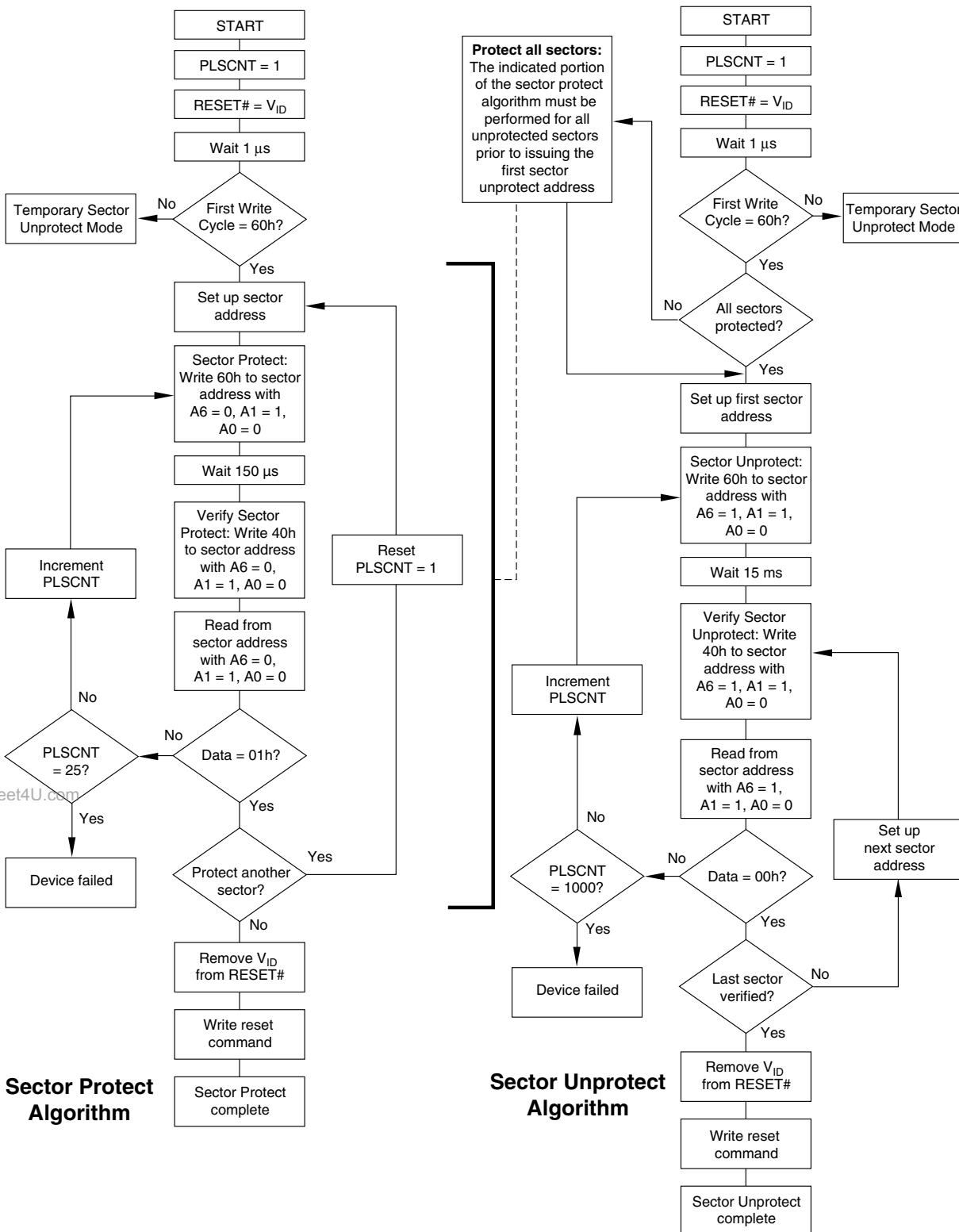

Figure 2. In-System Sector Protect/Unprotect Algorithms



Austin Semiconductor, Inc.

COTS PEM BOOT SECTOR FLASH AS29LV016

COMMON FLASH MEMORY INTERFACE (CFI)

The Common Flash Interface (CFI) specification outlines device and host system software interrogation handshake, which allows specific vendor-specified software algorithms to be used for entire families of devices. Software support can then be device-independent, JEDEC ID-independent, and forward- and backward-compatible for the specified flash device families. Flash vendors can standardize their existing interfaces for long-term compatibility.

This device enters the CFI Query mode when the system writes the CFI Query command, 98h, to address 55h in word mode (or address AAh in byte mode), any time the device is ready to read array data. The system can read CFI information at the addresses given in Tables 5–8. In word mode, the upper address bits (A7–MSB) must be all zeros. To terminate reading CFI data, the system must write the reset command.

The system can also write the CFI query command when the device is in the autoselect mode. The device enters the CFI query mode, and the system can read CFI data at the addresses given in Tables 5–8. The system must write the reset command to return the device to the autoselect mode.

Table 5: CFI Query Identification String

Addresses (Word Mode)	Addresses (Byte Mode)	Data	Description
10h 11h 12h	20h 22h 24h	0051h 0052h 0059h	Query Unique ASCII String "QRY"
13h 14h	26h 28h	0002h 0000h	Primary OEM Command Set
15h 16h	2Ah 2Ch	0040h 0000h	Address for Primary Extended Table
17h 18h	2Eh 30h	0000h 0000h	Alternate OEM Command Set (00h=none exists)
19h 1Ah	32h 34h	0000h 0000h	Address for Alternate OEM Extended Table (00h=none exists)



Austin Semiconductor, Inc.

COTS PEM BOOT SECTOR FLASH AS29LV016

Table 6: System Interface String

Addresses (Word Mode)	Addresses (Byte Mode)	Data	Description
1Bh	36h	0027h	V _{CC} Min. (write/erase) D7-D4:volt, D3-D0L 100 millivolt
1Ch	38h	0036h	V _{CC} Max. (write/erase) D7-D4:volt, D3-D0L 100 millivolt
1Dh	3Ah	0000h	V _{PP} Min. voltage (00h=no V _{PP} pin present)
1Eh	3Ch	0000h	V _{PP} Max. voltage (00h=no V _{PP} pin present)
1Fh	3Eh	0004h	Typical timeout per single byte/word write 2 ^N μs
20h	40h	0000h	Typical timeout for Min. size buffer write 2 ^N μs (00h=not supported)
21h	42h	000Ah	Typical timeout per individual block erase 2 ^N ms
22h	44h	0000h	Typical timeout for full chip erase 2 ^N ms (00h=not supported)
23h	46h	0005h	Max. timeout for byte/word write 2 ^N times typical
24h	48h	0000h	Max. timeout for buffer write 2 ^N times typical
25h	4Ah	0004h	Max. timeout per individual block erase 2 ^N times typical
26h	4Ch	0000h	Max. timeout for full chip erase 2 ^N times typical (00h=not supported)

Table 7: Device Geometry Definition

Addresses (Word Mode)	Addresses (Byte Mode)	Data	Description
27h	4Eh	0015h	Device Size = 2 ^N Byte
28h	50h	0002h	Flash Device Interface description (refer to CFI publication 100)
29h	52h	0000h	
2Ah	54h	0000h	Max. number of byte in multi-byte write = 2 ^N (00h= not supported)
2Bh	56h	0000h	
2Ch	58h	0004h	Number of Erase Block Regions within device
2Dh	5Ah	0000h	Erase Block Region 1 Information (refer to the CFI specification or CFI publication 100)
2Eh	5Ch	0000h	
2Fh	5Eh	0040h	
30h	60h	0000h	
31h	62h	0001h	Erase Block Region 2 Information
32h	64h	0000h	
33h	66h	0020h	
34h	68h	0000h	
35h	6Ah	0000h	Erase Block Region 3 Information
36h	6Ch	0000h	
37h	6Eh	0080h	
38h	70h	0000h	
39h	72h	001Eh	Erase Block Region 4 Information
3Ah	74h	0000h	
3Bh	76h	0000h	
3Ch	78h	0001h	



Austin Semiconductor, Inc.

COTS PEM BOOT SECTOR FLASH AS29LV016

Table 8: Primary Vendor-Specific Extended Query

Addresses (Word Mode)	Addresses (Byte Mode)	Data	Description
40h	80h	0050h	Query-unique ASCII string "PRI"
41h	82h	0052h	
42h	84h	0049h	
43h	86h	0031h	Major version number, ASCII
44h	88h	0030h	Major version number, ASCII
45h	8Ah	0000h	Address Sensitive Unlock 0=Required, 1=Not Required
46h	8Ch	0002h	Erase Suspend 0=Not Supported, 1=To Read Only, 2=To Read and Write
47h	8Eh	0001h	Sector Protect 0=Not Supported, X=Number of Sectors Per Group
48h	90h	0001h	Sector Temporary Unprotect 00=Not Supported, 01=Supported
49h	92h	0004h	Sector Protect / Unprotect Scheme 01=29F040 mode, 02=29F016 mode, 03=29F400 mode, 04=29LV800A mode
4Ah	94h	0000h	Simultaneous Operation 00=Not Supported, 01=Supported
4Bh	96h	0000h	Burst Mode Type 00=Not Supported, 01= Supported
4Ch	98h	0000h	Page Mode Type 00=Not Supported, 01=4 Word Page, 02= 8 Word Page

www.Datasheet4U.com HARDWARE DATA PROTECTION

The command sequence requirement of unlock cycles for programming or erasing provides data protection against inadvertent writes (refer to Table 9 on page 21 for command definitions). In addition, the following hardware data protection measures prevent accidental erasure or programming, which might otherwise be caused by spurious system level signals during V_{CC} power-up and power-down transitions, or from system noise.

LOW V_{CC} WRITE INHIBIT

When V_{CC} is less than V_{LKO} , the device does not accept any write cycles. This protects data during V_{CC} power-up and power-down. The command register and all internal program/erase circuits are disabled, and the device resets. Subsequent writes are ignored until V_{CC} is greater than V_{LKO} . The system must provide the proper signals to the control pins to prevent unintentional writes when V_{CC} is greater than V_{LKO} .

WRITE PULSE GLITCH PROTECTION

Noise pulses of less than 5 ns (typical) on OE#, CE# or WE# do not initiate a write cycle.

LOGICAL INHIBIT

Write cycles are inhibited by holding any one of OE# = V_{IL} , CE# = V_{IH} or WE# = V_{IH} . To initiate a write cycle, CE# and WE# must be a logical zero while OE# is a logical one.

POWER-UP WRITE INHIBIT

If WE# = CE# = V_{IL} and OE# = V_{IH} during power up, the device does not accept commands on the rising edge of WE#. The internal state machine is automatically reset to reading array data on power-up.



Austin Semiconductor, Inc.

COTS PEM BOOT SECTOR FLASH AS29LV016

COMMAND DEFINITIONS

Writing specific address and data commands or sequences into the command register initiates device operations. Table 9 on page 21 defines the valid register command sequences. Writing **incorrect address and data values** or writing them in the **improper sequence** resets the device to reading array data.

All addresses are latched on the falling edge of WE# or CE#, whichever happens later. All data is latched on the rising edge of WE# or CE#, whichever happens first. Refer to the appropriate timing diagrams in AC Characteristics on page 29.

READING ARRAY DATA

The device is automatically set to reading array data after device power-up. No commands are required to retrieve data. The device is also ready to read array data after completing an Embedded Program or Embedded Erase algorithm.

After the device accepts an Erase Suspend command, the device enters the Erase Suspend mode. The system can read array data using the standard read timings, except that if it reads at an address within erase-suspended sectors, the device outputs status data. After completing a programming operation in the Erase Suspend mode, the system may once again read array data with the same exception. See Erase Suspend/Erase Resume Commands on page 20 for more information on this mode.

The system must issue the reset command to re-enable the device for reading array data if DQ5 goes high, or while in the autoselect mode. See Reset Command, next.

See also Requirements for Reading Array Data on page 7 for more information. The Read Operations on page 29 provides the read parameters, and Figure 12, on page 29 shows the timing diagram.

RESET COMMAND

Writing the reset command to the device resets the device to reading array data. Address bits don't care for this command.

The reset command may be written between the sequence cycles in an erase command sequence before erasing begins. This resets the device to reading array data.

Once erasure begins, however, the device ignores reset commands until the operation is complete.

The reset command may be written between the sequence cycles in a program command sequence before programming begins. This resets the device to reading array data (also applies to programming in Erase Suspend mode). Once programming begins, however, the device ignores reset commands until the operation is complete.

The reset command may be written between the sequence cycles in an autoselect command sequence. Once in the autoselect mode, the reset command must be written to return to reading array data (also applies to autoselect during Erase Suspend).

If DQ5 goes high during a program or erase operation, writing the reset command returns the device to reading array data (also applies during Erase Suspend).

AUTOSELECT COMMAND SEQUENCE

The autoselect command sequence allows the host system to access the manufacturer and device codes, and determine whether or not a sector is protected. Table 9 on page 21 shows the address and data requirements. This method is an alternative to that shown in Table 4 on page 11, which is intended for PROM programmers and requires V_{ID} on address bit A9.

The autoselect command sequence is initiated by writing two unlock cycles, followed by the autoselect command. The device then enters the autoselect mode, and the system may read at any address any number of times, without initiating another command sequence.

A read cycle at address XX00h retrieves the manufacturer code. A read cycle at address XX01h returns the device code. A read cycle containing a sector address (SA) and the address 02h in word mode (or 04h in byte mode) returns 01h if that sector is protected, or 00h if it is unprotected. Refer to Table 2 on page 9 and Table 3 on page 10 for valid sector addresses.

The system must write the reset command to exit the autoselect mode and return to reading array data.



Austin Semiconductor, Inc.

COTS PEM BOOT SECTOR FLASH AS29LV016

WORD/BYTE PROGRAM COMMAND SEQUENCE

The system may program the device by word or byte, depending on the state of the BYTE# pin. Programming is a four-bus-cycle operation. The program command sequence is initiated by writing two unlock write cycles, followed by the program set-up command. The program address and data are written next, which in turn initiate the Embedded Program algorithm. The system is *not* required to provide further controls or timings. The device automatically generates the program pulses and verifies the programmed cell margin. Table 9 on page 21 shows the address and data requirements for the byte program command sequence.

When the Embedded Program algorithm is complete, the device then returns to reading array data and addresses are no longer latched. The system can determine the status of the program operation by using DQ7, DQ6, or RY/BY#. See Write Operation Status on page 22 for information on these status bits.

Any commands written to the device during the Embedded Program Algorithm are ignored. Note that a **hardware reset** immediately terminates the programming operation. The Byte Program command sequence should be reinitiated once the device has reset to reading array data, to ensure data integrity.

Programming is allowed in any sequence and across sector boundaries. **A bit cannot be programmed from a 0 back to a 1.** Attempting to do so may halt the operation and set DQ5 to 1, or cause the Data# Polling algorithm to indicate the operation was successful. However, a succeeding read will show that the data is still 0. Only erase operations can convert a 0 to a 1.

UNLOCK BYPASS COMMAND SEQUENCE

The unlock bypass feature allows the system to program bytes or words to the device faster than using the standard program command sequence. The unlock bypass command sequence is initiated by first writing two unlock cycles. This is followed by a third write cycle containing the unlock bypass command, 20h. The device then enters the unlock bypass mode. A two-cycle unlock bypass program command sequence is all that is required to program in this mode. The first cycle in this sequence contains the unlock bypass program command, A0h; the second cycle contains the program address and data. Additional data is programmed in the same manner.

This mode dispenses with the initial two unlock cycles required in the standard program command sequence, resulting in faster total programming time. Table 9 on page 21 shows the requirements for the command sequence.

During the unlock bypass mode, only the Unlock Bypass Program and Unlock Bypass Reset commands are valid. To exit the unlock bypass mode, the system must issue the two-cycle unlock bypass reset command sequence. The first cycle must contain the data 90h; the second cycle the data 00h. Addresses are don't care for both cycles. The device then returns to reading array data.

Figure 3 illustrates the algorithm for the program operation. See Erase / Program Operations on page 32 for parameters, and to Figure 16, on page 33 for timing diagrams.

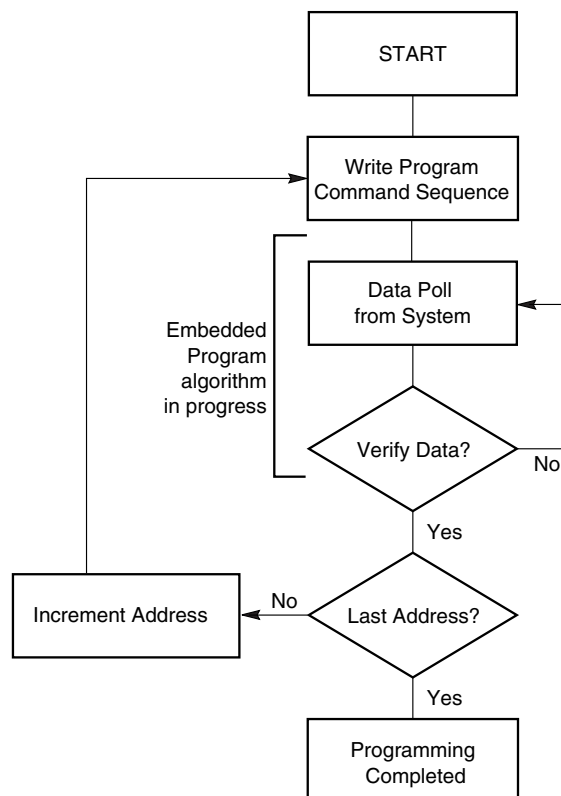

Note: See Table 9 on page 21 for program command sequence.

Figure 3. Program Operation



Austin Semiconductor, Inc.

COTS PEM BOOT SECTOR FLASH AS29LV016

CHIP ERASE COMMAND SEQUENCE

Chip erase is a six bus cycle operation. The chip erase command sequence is initiated by writing two unlock cycles, followed by a set-up command. Two additional unlock write cycles are then followed by the chip erase command, which in turn invokes the Embedded Erase algorithm. The device does not require the system to preprogram prior to erase. The Embedded Erase algorithm automatically preprograms and verifies the entire memory for an all zero data pattern prior to electrical erase. The system is not required to provide any controls or timings during these operations. Table 9 on page 21 shows the address and data requirements for the chip erase command sequence.

Any commands written to the chip during the Embedded Erase algorithm are ignored. Note that a **hardware reset** during the chip erase operation immediately terminates the operation. The Chip Erase command sequence should be reinitiated once the device has returned to reading array data, to ensure data integrity.

The system can determine the status of the erase operation by using DQ7, DQ6, DQ2, or RY/BY#. See Write Operation Status on page 22 for information on these status bits. When the Embedded Erase algorithm is complete, the device returns to reading array data and addresses are no longer latched.

Figure 4, on page 20 illustrates the algorithm for the erase operation. See Erase / Program Operations on page 32 for parameters, and Figure 17, on page 33 for timing diagrams.

SECTOR ERASE COMMAND SEQUENCE

Sector erase is a six bus cycle operation. The sector erase command sequence is initiated by writing two unlock cycles, followed by a set-up command. Two additional unlock write cycles are then followed by the address of the sector to be erased, and the sector erase command. Table 9 on page 21 shows the address and data requirements for the sector erase command sequence.

The device does *not* require the system to preprogram the memory prior to erase. The Embedded Erase algorithm automatically programs and verifies the sector for an all zero data pattern prior to electrical erase. The system is not required to provide any controls or timings during these operations.

After the command sequence is written, a sector erase time-out of 50 μ s begins. During the time-out period, additional sector addresses and sector erase commands may be written. Loading the sector erase buffer may be done in any sequence, and the number of sectors may be from one sector to all sectors. The time between these additional cycles must be less than 50 μ s, otherwise the last address and command might not be accepted, and erasure may begin. It is recommended that processor interrupts be disabled during this time to ensure all commands are accepted. The interrupts can be re-enabled after the last Sector Erase command is written. If the time between additional sector erase commands can be assumed to be less than 50 μ s, the system need not monitor DQ3. **Any command other than Sector Erase or Erase Suspend during the time-out period resets the device to reading array data.** The system must rewrite the command sequence and any additional sector addresses and commands.

The system can monitor DQ3 to determine if the sector erase timer has timed out. (See DQ3: Sector Erase Timer on page 25.) The time-out begins from the rising edge of the final WE# pulse in the command sequence.

Once the sector erase operation has begun, only the Erase Suspend command is valid. All other commands are ignored. Note that a **hardware reset** during the sector erase operation immediately terminates the operation. The Sector Erase command sequence should be reinitiated once the device has returned to reading array data, to ensure data integrity.

When the Embedded Erase algorithm is complete, the device returns to reading array data and addresses are no longer latched. The system can determine the status of the erase operation by using DQ7, DQ6, DQ2, or RY/BY#. (Refer to Write Operation Status on page 22 for information on these status bits.)

Figure 4 illustrates the algorithm for the erase operation. Refer to Erase / Program Operations on page 32 for parameters, and to Figure 17, on page 33 for timing diagrams.



Austin Semiconductor, Inc.

COTS PEM BOOT SECTOR FLASH AS29LV016

ERASE SUSPEND / ERASE RESUME COMMANDS

The Erase Suspend command allows the system to interrupt a sector erase operation and then read data from, or program data to, any sector not selected for erasure. This command is valid only during the sector erase operation, including the 50 μ s time-out period during the sector erase command sequence. The Erase Suspend command is ignored if written during the chip erase operation or Embedded Program algorithm. Writing the Erase Suspend command during the Sector Erase time-out immediately terminates the time-out period and suspends the erase operation. Addresses are don't-cares when writing the Erase Suspend command.

When the Erase Suspend command is written during a sector erase operation, the device requires a maximum of 20 μ s to suspend the erase operation. However, when the Erase Suspend command is written during the sector erase time-out, the device immediately terminates the time-out period and suspends the erase operation.

After the erase operation has been suspended, the system can read array data from or program data to any sector not selected for erasure. (The device "erase suspends" all sectors selected for erasure.) Normal read and write timings and command definitions apply. Reading at any address within erase-suspended sectors produces status data on DQ7–DQ0. The system can use DQ7, or DQ6 and DQ2 together, to determine if a sector is actively erasing or is erase-suspended. See Write Operation Status on page 22 for information on these status bits.

After an erase-suspended program operation is complete, the system can once again read array data within non-suspended sectors. The system can determine the status of the program operation using the DQ7 or DQ6 status bits, just as in the standard program operation. See Write Operation Status on page 22 for more information.

The system may also write the autoselect command sequence when the device is in the Erase Suspend mode. The device allows reading autoselect codes even at addresses within erasing sectors, since the codes are not stored in the memory array. When the device exits the autoselect mode, the device reverts to the Erase Suspend mode, and is ready for another valid operation. See Autoselect Command Sequence on page 17 for more information.

The system must write the Erase Resume command (address bits are don't care) to exit the erase suspend mode and continue the sector erase operation. Further writes of the Resume command are ignored. Another Erase Suspend command can be written after the device has resumed erasing.

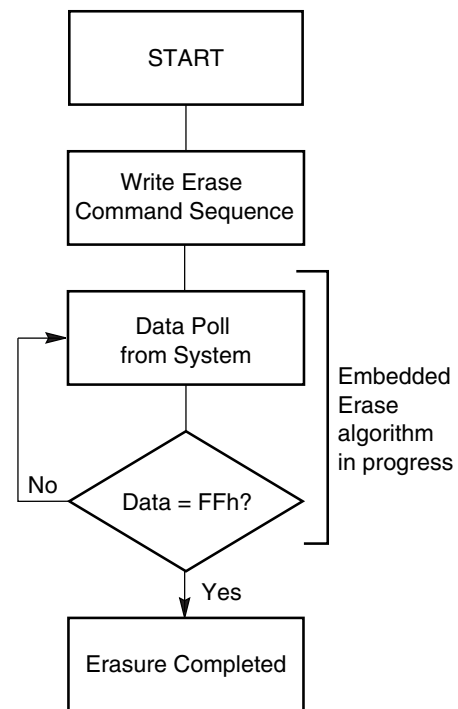

Notes:

1. See Table 9 on page 21 for erase command sequence.
2. See DQ3: Sector Erase Timer on page 25 for more information.

Figure 4. Erase Operation



Austin Semiconductor, Inc.

COTS PEM BOOT SECTOR FLASH AS29LV016

TABLE 9: COMMAND DEFINITIONS

Command Sequence ¹		Cycles	Bus Cycles ²⁻⁵											
			First		Second		Third		Fourth		Fifth		Sixth	
			Addr	Data	Addr	Data	Addr	Data	Addr	Data	Addr	Data	Addr	Data
Read ⁶		1	RA	RD										
Reset ⁷		1	XXX	F0										
Autoselect ⁸	Manufacturer ID	Word	555	AA	2AA	55	555	90	X00	01				
		Byte	AAA		555		AAA							
	Device ID, Top Boot Block	Word	555	AA	2AA	55	555	90	X01	22C4				
		Byte	AAA		555		AAA		X02	C4				
	Device ID, Bottom Boot Block	Word	555	AA	2AA	55	555	90	X01	2249				
		Byte	AAA		555		AAA		X02	49				
	Sector Protect Verify ⁹	Word	555	AA	2AA	55	555	90	(SA) X02	XX00 XX01				
		Byte	AAA		555		AAA		(SA) X04	00 01				
CFI Query ¹⁰		Word	55	98										
		Byte	AA											
Program		Word	555	AA	2AA	55	555	A0	PA	PD				
		Byte	AAA		555		AAA							
Unlock Bypass		Word	555	AA	2AA	55	555	20						
		Byte	AAA		555		AAA							
Unlock Bypass Program ¹¹		2	XXX	A0	PA	PD								
Unlock Bypass Reset ¹²		2	XXX	90	XXX	F0								
Chip Erase		Word	555	AA	2AA	55	555	80	555	AA	2AA	55	555	10
		Byte	AAA		555		AAA		AAA		555		AAA	
Sector Erase		Word	555	AA	2AA	55	555	80	555	AA	2AA	55	SA	30
		Byte	AAA		555		AAA		AAA		555			
Erase Suspend ¹³		1	XXX	B0										
Erase Resume ¹⁴		1	XXX	30										

Legend:

X = Don't care

RA = Address of the memory location to be read.

RD = Data read from location RA during read operation.

PA = Address of the memory location to be programmed. Addresses latch on the falling edge of the WE# or CE# pulse, whichever happens later.

PD = Data to be programmed at location PA. Data latches on the rising edge of WE# or CE# pulse, whichever happens first.

SA = Address of the sector to be verified (in autoselect mode) or erased. Address bits A19–A12 uniquely select any sector.

Note:

- See Table 1 for description of bus operations.
- All values are in hexadecimal.
- Except for the read cycle and the fourth cycle of the autoselect command sequence, all bus cycles are write cycles.
- Data bits DQ15–DQ8 are don't cares for unlock and command cycles.
- Address bits A19–A11 are don't cares for unlock and command cycles, unless SA or PA required.
- No unlock or command cycles required when reading array data.
- The Reset command is required to return to reading array data when device is in the autoselect mode, or if DQ5 goes high (while the device is providing status data).
- The fourth cycle of the autoselect command sequence is a read cycle.
- The data is 00h for an unprotected sector and 01h for a protected sector. See "Autoselect Command Sequence" for more information.
- Command is valid when device is ready to read array data or when device is in autoselect mode.
- The Unlock Bypass command is required prior to the Unlock Bypass Program command.
- The Unlock Bypass Reset command is required to return to reading array data when the device is in the unlock bypass mode. F0 is also acceptable.
- The system may read and program in non-erasing sectors, or enter the autoselect mode, when in the Erase Suspend mode. The Erase Suspend command is valid only during a sector erase operation.
- The Erase Resume command is valid only during the Erase Suspend mode.



Austin Semiconductor, Inc.

COTS PEM BOOT SECTOR FLASH AS29LV016

WRITE OPERATION STATUS

The device provides several bits to determine the status of a write operation: DQ2, DQ3, DQ5, DQ6, DQ7, and RY/BY#. Table 10 on page 25 and the following subsections describe the functions of these bits. DQ7, RY/BY#, and DQ6 each offer a method for determining whether a program or erase operation is complete or in progress. These three bits are discussed first.

DQ7: DATA# POLLING

The Data# Polling bit, DQ7, indicates to the host system whether an Embedded Algorithm is in progress or completed, or whether the device is in Erase Suspend. Data# Polling is valid after the rising edge of the final WE# pulse in the program or erase command sequence.

During the Embedded Program algorithm, the device outputs on DQ7 the complement of the datum programmed to DQ7. This DQ7 status also applies to programming during Erase Suspend. When the Embedded Program algorithm is complete, the device outputs the datum programmed to DQ7. The system must provide the program address to read valid status information on DQ7. If a program address falls within a protected sector, Data# Polling on DQ7 is active for approximately 1 μ s, then the device returns to reading array data.

During the Embedded Erase algorithm, Data# Polling produces a 0 on DQ7. When the Embedded Erase algorithm is complete, or if the device enters the Erase Suspend mode, Data# Polling produces a 1 on DQ7. This is analogous to the complement/true datum output described for the Embedded Program algorithm: the erase function changes all the bits in a sector to 1; prior to this, the device outputs the *complement*, or 0. The system must provide an address within any of the sectors selected for erasure to read valid status information on DQ7.

After an erase command sequence is written, if all sectors selected for erasing are protected, Data# Polling on DQ7 is active for approximately 100 μ s, then the device returns to reading array data. If not all selected sectors are protected, the Embedded Erase algorithm erases the unprotected sectors, and ignores the selected sectors that are protected.

When the system detects DQ7 has changed from the complement to true data, it can read valid data at DQ7–DQ0 on the *following* read cycles. This is because DQ7 may change asynchronously with DQ0–DQ6 while Output Enable (OE#) is asserted low. Figure 18, on page 34, illustrates this.

Table 10 on page 25 shows the outputs for Data# Polling on DQ7. Figure 5 below shows the Data# Polling algorithm.

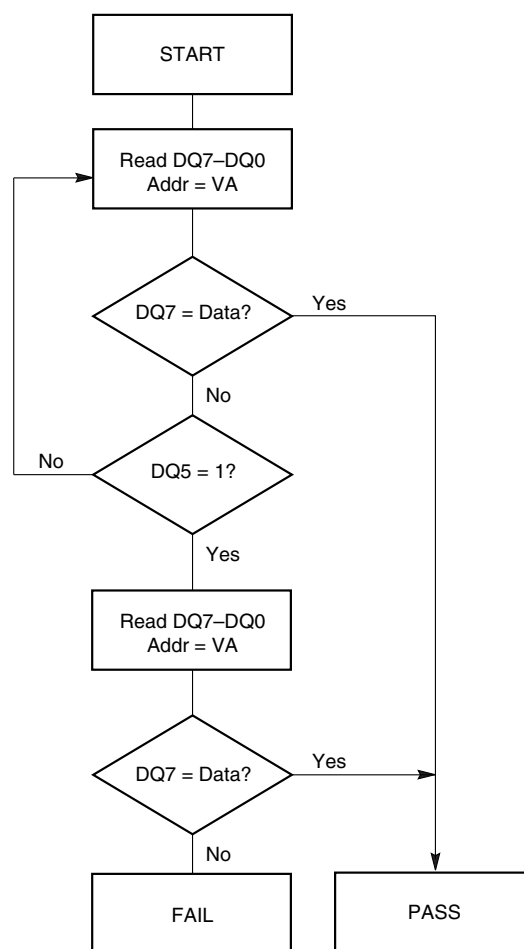

Notes:

1. VA = Valid address for programming. During a sector erase operation, a valid address is an address within any sector selected for erasure. During chip erase, a valid address is any non-protected sector address.
2. DQ7 should be rechecked even if DQ5 = 1 because DQ7 may change simultaneously with DQ5.

Figure 5. Data# Polling Algorithm



Austin Semiconductor, Inc.

COTS PEM BOOT SECTOR FLASH AS29LV016

RY/BY#: READY/BUSY#

The RY/BY# is a dedicated, open-drain output pin that indicates whether an Embedded Algorithm is in progress or complete. The RY/BY# status is valid after the rising edge of the final WE# pulse in the command sequence. Since RY/BY# is an open-drain output, several RY/BY# pins can be tied together in parallel with a pull-up resistor to VCC.

If the output is low (Busy), the device is actively erasing or programming. (This includes programming in the Erase Suspend mode.) If the output is high (Ready), the device is ready to read array data (including during the Erase Suspend mode), or is in the standby mode.

Table 10 on page 25 shows the outputs for RY/BY#. Figures: Figure 12, on page 29, Figure 13, on page 30, Figure 16, on page 33 and Figure 17, on page 33 shows RY/BY# for read, reset, program, and erase operations, respectively.

DQ6: TOGGLE BIT I

Toggle Bit I on DQ6 indicates whether an Embedded Program or Erase algorithm is in progress or complete, or whether the device has entered the Erase Suspend mode. Toggle Bit I may be read at any address, and is valid after the rising edge of the final WE# pulse in the command sequence (prior to the program or erase operation), and during the sector erase time-out.

During an Embedded Program or Erase algorithm operation, successive read cycles to any address cause DQ6 to toggle. (The system may use either OE# or CE# to control the read cycles.) When the operation is complete, DQ6 stops toggling.

After an erase command sequence is written, if all sectors selected for erasing are protected, DQ6 toggles for approximately 100 μ s, then returns to reading array data. If not all selected sectors are protected, the Embedded Erase algorithm erases the unprotected sectors, and ignores the selected sectors that are protected.

The system can use DQ6 and DQ2 together to determine whether a sector is actively erasing or is erase-suspended. When the device is actively erasing (that is, the Embedded Erase algorithm is in progress), DQ6 toggles. When the device enters the Erase Suspend mode, DQ6 stops toggling. However, the system must also use DQ2 to determine which sectors are erasing or erase-suspended. Alternatively, the system can use DQ7 (see the subsection on DQ7: Data# Polling on page 22).

If a program address falls within a protected sector, DQ6 toggles for approximately 1 μ s after the program command sequence is written, then returns to reading array data.

DQ6 also toggles during the erase-suspend-program mode, and stops toggling once the Embedded Program algorithm is complete.

Table 10 on page 25 shows the outputs for Toggle Bit I on DQ6. Figure 6, on page 24 shows the toggle bit algorithm in flowchart form, and Reading Toggle Bits DQ6/DQ2 on page 24 explains the algorithm. Figure 19, on page 34 shows the toggle bit timing diagrams. Figure 20, on page 5 shows the differences between DQ2 and DQ6 in graphical form. See also the subsection on DQ2: Toggle Bit II below.

DQ2: TOGGLE BIT II

The "Toggle Bit II" on DQ2, when used with DQ6, indicates whether a particular sector is actively erasing (that is, the Embedded Erase algorithm is in progress), or whether that sector is erase-suspended. Toggle Bit II is valid after the rising edge of the final WE# pulse in the command sequence.

DQ2 toggles when the system reads at addresses within those sectors that have been selected for erasure. (The system may use either OE# or CE# to control the read cycles.) But DQ2 cannot distinguish whether the sector is actively erasing or is erase-suspended. DQ6, by comparison, indicates whether the device is actively erasing, or is in Erase Suspend, but cannot distinguish which sectors are selected for erasure. Thus, both status bits are required for sector and mode information. Refer to Table 10 on page 25 to compare outputs for DQ2 and DQ6.

Figure 6, on page 24 shows the toggle bit algorithm in flowchart form, and the section Reading Toggle Bits DQ6/DQ2 on page 24 explains the algorithm. See also the DQ6: Toggle Bit I subsection. Figure 19, on page 34 shows the toggle bit timing diagram. Figure 20, on page 35 shows the differences between DQ2 and DQ6 in graphical form.

READING TOGGLE BITS DQ6/DQ2

Refer to Figure 6 for the following discussion. Whenever the system initially begins reading toggle bit status, it must read DQ7–DQ0 at least twice in a row to determine whether a toggle bit is toggling. Typically, the system would note and store the value of the toggle bit after the first read. After the second read, the system would compare the new value of the toggle bit with the first. If the toggle bit is not toggling, the device has completed the program or erase operation. The system can read array data on DQ7–DQ0 on the following read cycle.

However, if after the initial two read cycles, the system determines that the toggle bit is still toggling, the system also should note whether the value of DQ5 is high (see the section on DQ5). If it is, the system should then determine again whether the toggle bit is toggling, since the toggle bit may have stopped toggling just as DQ5 went high. If the toggle bit is no longer toggling, the device has successfully completed the program or erase operation. If it is still toggling, the device did not complete the operation successfully, and the system must write the reset command to return to reading array data.

The remaining scenario is that the system initially determines that the toggle bit is toggling and DQ5 has not gone high. The system may continue to monitor the toggle bit and DQ5 through successive read cycles, determining the status as described in the previous paragraph. Alternatively, it may choose to perform other system tasks. In this case, the system must start at the beginning of the algorithm when it returns to determine the status of the operation (top of Figure 6).

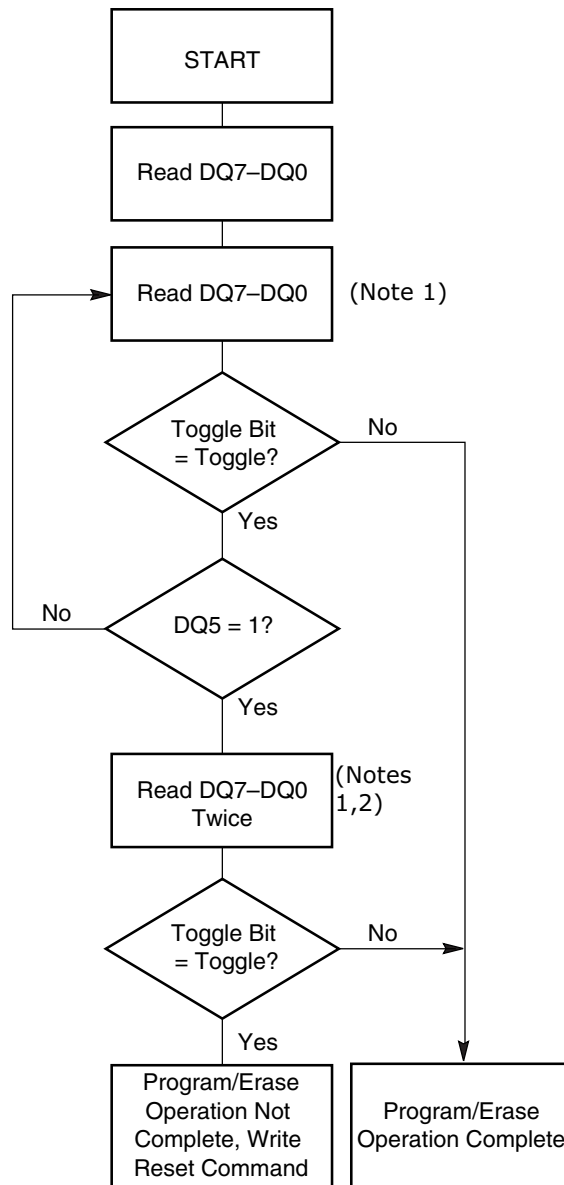

Notes:

1. Read toggle bit twice to determine whether or not it is toggling. See text.
2. Recheck toggle bit because it may stop toggling as DQ5 changes to 1. See text.

Figure 6. Toggle Bit Algorithm



Austin Semiconductor, Inc.

COTS PEM BOOT SECTOR FLASH AS29LV016

DQ5: EXCEEDED TIMING LIMITS

DQ5 indicates whether the program or erase time has exceeded a specified internal pulse count limit. Under these conditions DQ5 produces a 1. This is a failure condition that indicates the program or erase cycle was not successfully completed.

The DQ5 failure condition may appear if the system tries to program a 1 to a location that is previously programmed to 0. **Only an erase operation can change a 0 back to a 1.** Under this condition, the device halts the operation, and when the operation has exceeded the timing limits, DQ5 produces a 1.

Under both these conditions, the system must issue the reset command to return the device to reading array data.

After the sector erase command sequence is written, the system should read the status on DQ7 (Data# Polling) or DQ6 (Toggle Bit I) to ensure the device has accepted the command sequence, and then read DQ3. If DQ3 is 1, the internally controlled erase cycle has begun; all further commands (other than Erase Suspend) are ignored until the erase operation is complete. If DQ3 is 0, the device will accept additional sector erase commands. To ensure the command has been accepted, the system software should check the status of DQ3 prior to and following each subsequent sector erase command. If DQ3 is high on the second status check, the last command might not have been accepted. Table 10 shows the outputs for DQ3.

DQ3: SECTOR ERASE TIMER

After writing a sector erase command sequence, the system may read DQ3 to determine whether or not an erase operation has begun. (The sector erase timer does not apply to the chip erase command.) If additional sectors are selected for erasure, the entire time-out also applies after each additional sector erase command. When the time-out is complete, DQ3 switches from 0 to 1. The system may ignore DQ3 if the system can guarantee that the time between additional sector erase commands will always be less than 50 μ s. See also the Sector Erase Command Sequence section on page 19.

Table 10: Write Operation Status

Operation		DQ7 ²	DQ6	DQ1 ¹	DQ3	DQ2 ²	RY/BY#
Standard Mode	Embedded Program Algorithm	DQ7#	Toggle	0	N/A	No Toggle	0
	Embedded Erase Algorithm	0	Toggle	0	1	Toggle	0
Erase Suspend Mode	Reading within Erase Suspended Sector	1	No Toggle	0	N/A	Toggle	1
	Reading within Non-Erase Suspended Sector	Data	Data	Data	Data	Data	1
	Erase-Suspend-Program	DQ7#	Toggle	0	N/A	N/A	0

Notes:

1. DQ5 switches to 1 when and Embedded Program or Embedded Erase operation has exceeded the maximum timing limits. See DQ5: Exceeded Timing Limits for more information.
2. DQ7 and DQ2 require a valid address when reading status information. Refer to the appropriate subsection for further details.



Austin Semiconductor, Inc.

**COTS PEM
BOOT SECTOR FLASH
AS29LV016**

ABSOLUTE MAXIMUM RATINGS

Storage Temperature Plastic Packages	-65°C to +150°C
Ambient Temperature with Power Applied	-65°C to +125°C
Voltage with Respect to Ground	
V_{CC}^1	-0.5 V to +4.0 V
A9, OE#, and RESET# ²	-0.5 V to +12.5 V
All other pins ¹	-0.5 V to $V_{CC}+0.5$ V
Output Short Circuit Current ³200 mA

Notes:

1. Minimum DC voltage on input or I/O pins is -0.5 V. During voltage transitions, input or I/O pins may overshoot V_{SS} to -2.0 V for periods of up to 20 ns. See Figure 7 below. Maximum DC voltage on input or I/O pins is $V_{CC} + 0.5$ V. During voltage transitions, input or I/O pins may overshoot to $V_{CC} + 2.0$ V for periods up to 20 ns. See Figure 8 below.
2. Minimum DC input voltage on pins A9, OE#, and RESET# is -0.5 V. During voltage transitions, A9, OE#, and RESET# may overshoot V_{SS} to -2.0 V for periods of up to 20 ns. See Figure 7 below. Maximum DC input voltage on pin A9 is +12.5 V which may overshoot to 14.0 V for periods up to 20 ns.
3. No more than one output may be shorted to ground at a time. Duration of the short circuit should not be greater than one second.

Stresses above those listed under Absolute Maximum Ratings may cause permanent damage to the device. This is a stress rating only; functional operation of the device at these or any other conditions above those indicated in the operational sections of this data sheet is not implied. Exposure of the device to absolute maximum rating conditions for extended periods may affect device reliability.

OPERATING RANGES

Enhanced (/ET) Devices

Ambient Temperature (TA). -40°C to +105°C

www.DataSheet4U.com

Extended (/XT) Devices

Ambient Temperature (TA). -55°C to +125°C

V_{CC} Supply Voltages

V_{CC} for standard voltage range. 2.7 V to 3.6 V

Operating ranges define those limits between which the functionality of the device is guaranteed.

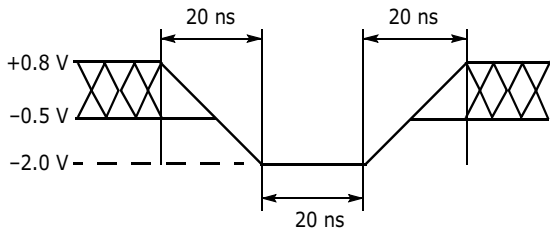

Figure 7. Maximum Negative Overshoot Waveform

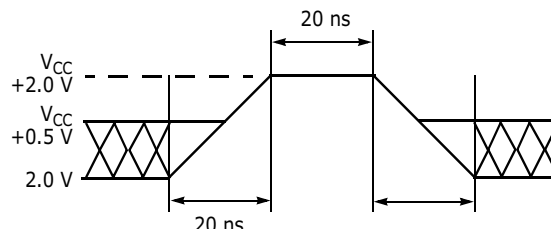

Figure 8. Maximum Positive Overshoot Waveform



Austin Semiconductor, Inc.

COTS PEM BOOT SECTOR FLASH AS29LV016

DC CHARACTERISTICS

CMOS Compatible

Parameter	Description	Test Conditions	Min	Typ	Max	Unit	
I_{LI}	Input Load Current	$V_{IN}=V_{SS}$ to V_{CC} , $V_{CC}=V_{CCmax}$			± 1.0	μA	
I_{LIT}	A9 Input Load Current	$V_{CC}=V_{CCmax}$; A9=12.5V			35		
I_{LO}	Output Leakage Current	$V_{OUT}=V_{SS}$ to V_{CC} , $V_{CC}=V_{CCmax}$			± 1.0		
I_{CC1}	V_{CC} Active Read Current ^{1,2}	CE#= V_{IL} , OE#= V_{IH} , Byte Mode		10 MHz	15	30	mA
				5 MHz	9	16	
				1 MHz	2	4	
		CE#= V_{IL} , OE#= V_{IH} , Word Mode		10 MHz	18	35	
				5 MHz	9	16	
				1 MHz	2	4	
I_{CC2}	V_{CC} Active Write Current ^{2,3,5}	CE#= V_{IL} , OE#= V_{IH}		20	35	mA	
I_{CC3}	V_{CC} Standby Current ^{2,4}	CE#, RESET#= $V_{CC} \pm 0.3V$		0.2	5	μA	
I_{CC4}	V_{CC} Standby Current During Reset ^{2,4}	RESET#= $V_{SS} \pm 0.3V$		0.2		μA	
I_{CC5}	Automatic Sleep Mode ^{2,4,6}	$V_{IH}=V_{CC} \pm 0.3V$; $V_{IL}=V_{SS} \pm 0.3V$		0.2		μA	
V_{IL}	Input Low Voltage		-0.5		0.8	V	
V_{IH}	Input High Voltage		$0.7 \times V_{CC}$		$V_{CC} + 0.3$		
V_{ID}	Voltage for Autoselect and Temporary Sector Unprotect	$V_{CC}=3.3V$	11.5		12.5		
V_{OL}	Output Low Voltage	$I_{OL}=4.0 mA$, $V_{CC}=V_{CCmin}$			0.45		
V_{OH1}	Output High Voltage	$I_{OH}=-2.0 mA$, $V_{CC}=V_{CCmin}$	2.4				
V_{OH2}		$I_{OH}=-100 \mu A$, $V_{CC}=V_{CCmin}$	$V_{CC}-0.4$				
V_{LKO}	Low V_{CC} Lock-Out Voltage		2.3		2.5		

Notes:

1. The I_{CC} current listed is typically less than 2 mA/MHz, with OE# at V_{IH} . Typical V_{CC} is 3.0 V.

2. Maximum I_{CC} specifications are tested with $V_{CC} = V_{CCmax}$.

3. I_{CC} active while Embedded Erase or Embedded Program is in progress.

4. At extended temperature range (>+85°C), typical current is 5 μA and maximum current is 10 μA .

5. Automatic sleep mode enables the low power mode when addresses remain stable for $t_{ACC} + 30 ns$. Typical sleep mode current is 200 nA.

6. Not 100% tested.



Austin Semiconductor, Inc.

**COTS PEM
BOOT SECTOR FLASH
AS29LV016**

TEST CONDITIONS

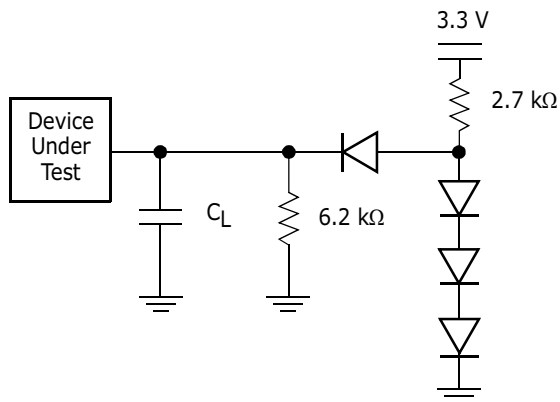

Note: Diodes are IN3064 or equivalent

Figure 10. Test Setup

Table 11: Test Specifications

Test Condition	70	90	100	Unit
Output Load	1 TTL gate			
Output Load Capacitance, CL (including jig capacitance)	30	100	100	pF
Input Rise and Fall Times	5			ns
Input Pulse Levels	0.0 or V _{CC}			V
Input timing measurement reference levels	0.5 V _{CC}			
Output timing measurement reference levels	0.5 V _{CC}			

Key to Switching Waveforms

www.DataSheet4U.com

WAVEFORM	INPUTS	OUTPUTS
	Steady	
	Changing from H to L	
	Changing from L to H	
	Don't Care, Any Change Permitted	Changing, State Unknown
	Does Not Apply	Center Line is High Impedance State (High Z)

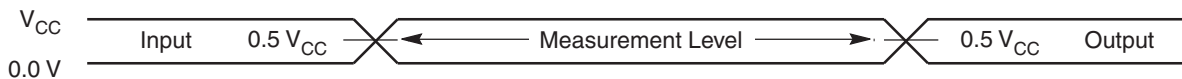

Figure 11. Input Waveforms and Measurement Levels



Austin Semiconductor, Inc.

**COTS PEM
BOOT SECTOR FLASH
AS29LV016**

AC CHARACTERISTICS

Read Operations

Parameter		Description	Test Setup	Speed Options			Unit	
JEDEC	Std			70	90	100		
t_{AVAV}	t_{RC}	Read Cycle Time ¹	Min	70	90	100	ns	
t_{AVQV}	t_{ACC}	Address to Output Delay	CE#=V _{IL} , OE#=V _{IL}	Max	70	90		100
t_{ELQV}	t_{CE}	Chip Enable to Output Delay	OE#=V _{IL}	Max	70	90		100
t_{GLQV}	t_{OE}	Output Enable to Output Delay		Max	30	35		40
t_{EHQZ}	t_{DF}	Chip Enable to Output High Z ¹		Max	25	30		35
t_{GHQZ}	t_{DF}	Output Enable to Output High Z ¹		Max	25	30		35
	$t_{SR/W}$	Latency Between Read and Write Operations		Min	20			
	t_{OEh}	Output Enable Hold Time ¹	Read	Min	0			
		Toggle and Data# Polling	Min	10				
t_{AXQX}	t_{OH}	Output Hold Time From Addresses, CE# or OE#, Whichever Occurs First ¹	Min	0				

Notes:

1. Not 100% Tested
2. See Figure 10, on page 28 and Table 11 on page 28 for test specifications.



www.DataSheet4U.com

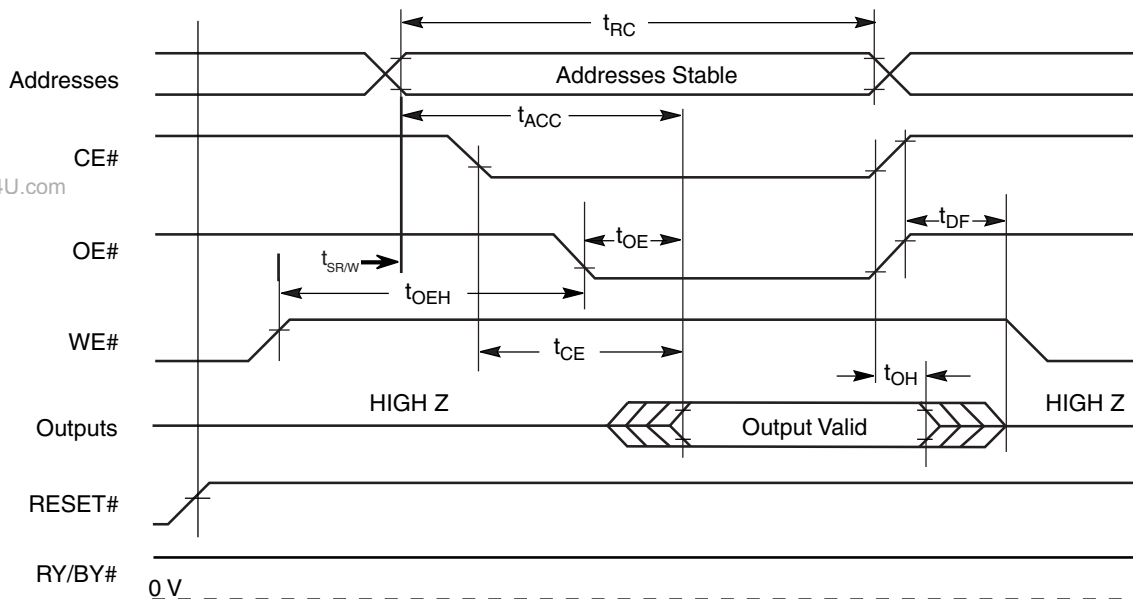

Figure 12. Read Operations Timings



Austin Semiconductor, Inc.

**COTS PEM
BOOT SECTOR FLASH
AS29LV016**

AC CHARACTERISTICS

Hardware Reset (RESET#)

Parameter		Description	Test Setup	All Speed Options	Unit
JEDEC	Std				
	t_{READY}	RESET# Pin Low (During Embedded Algorithms) to Read or Write ¹	Max	20	μ s
	t_{READY}	RESET# Pin Low (NOT During Embedded Algorithms) to Read or Write ¹	Max	500	ns
	t_{RP}	RESET# Pulse Width	Min	500	
	t_{RH}	RESET# High Time Before Read ¹		50	
	t_{RPD}	RESET# Low to Standby Mode		20	μ s
	t_{RB}	RY/BY# Recovery Time		0	ns

Note:

- 1. Not 100% Tested

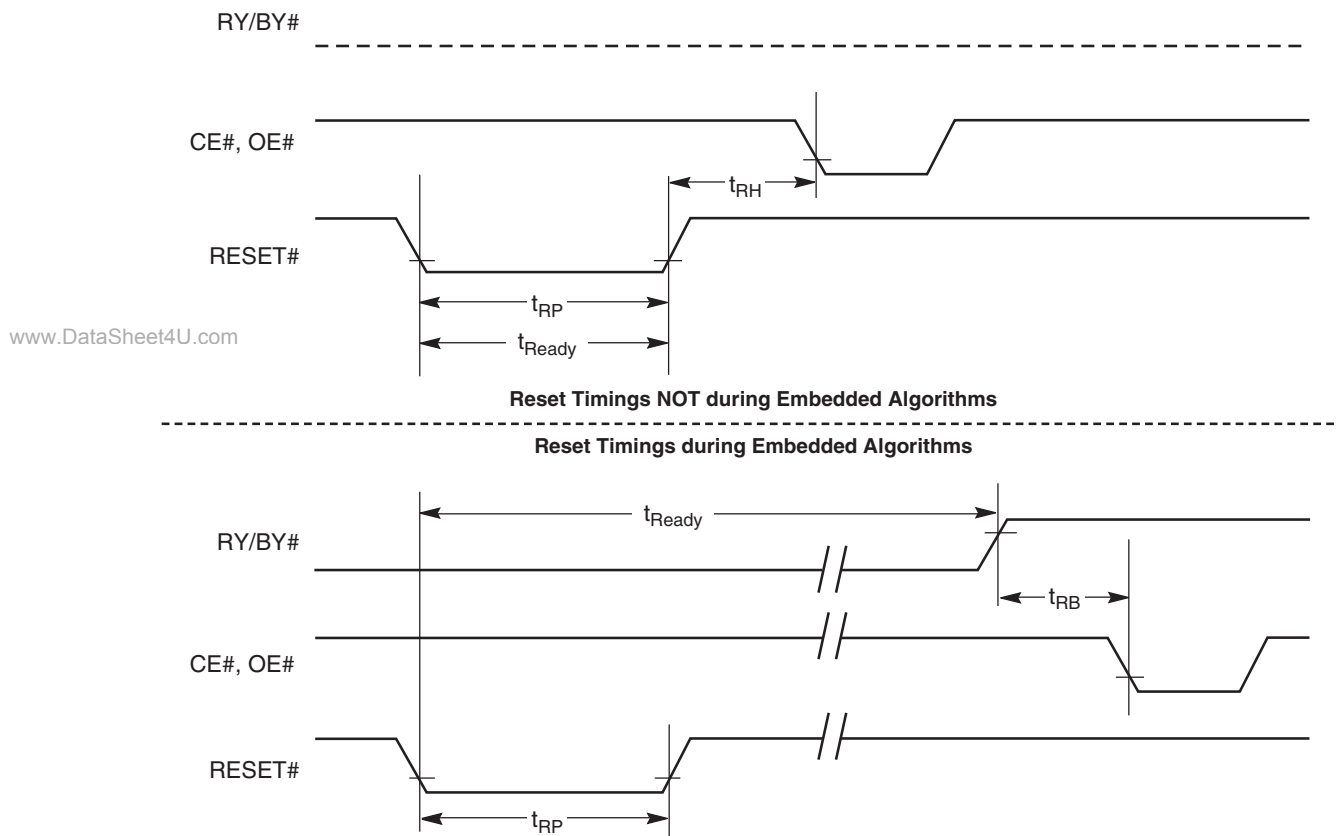

Figure I3. RESET# Timings



Austin Semiconductor, Inc.

**COTS PEM
BOOT SECTOR FLASH
AS29LV016**

AC CHARACTERISTICS

Word / Byte Configuration (BYTE#)

Parameter		Description	Test Setup	Speed Options			Unit
JEDEC	Std			70	90	100	
	t_{ELFL} / t_{ELFH}	CE# to BYTE# Switching Low or High	Max	5			ns
	t_{FLQZ}	BYTE# Switching Low to Output HIGH Z	Max	25	30	35	
	t_{FHQV}	BYTE# Switching High to Output Active	Min	70	90	100	

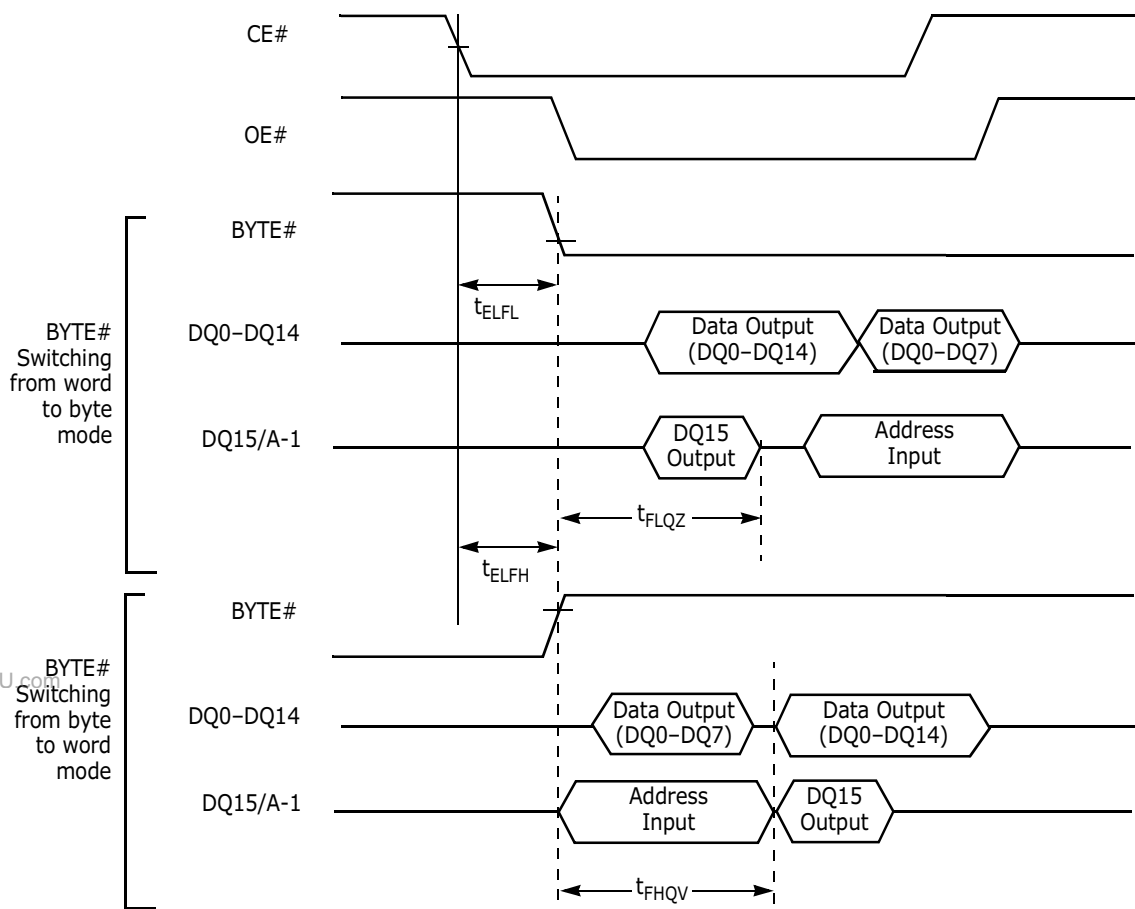

Figure I4. BYTE# Timings for Read Operations



Austin Semiconductor, Inc.

COTS PEM BOOT SECTOR FLASH AS29LV016

AC CHARACTERISTICS

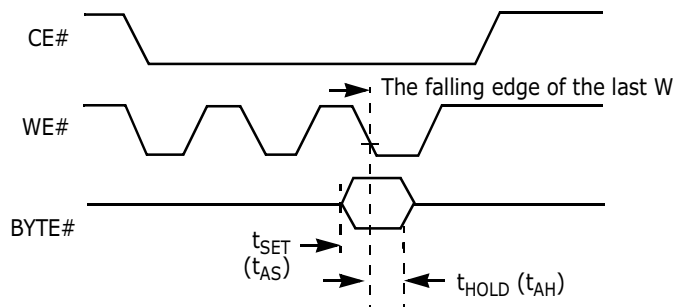

Note: Refer to the Erase/Program Operations table for t_{AS} and t_{AH} specifications.

Figure I5. BYTE# Timings for Write Operations

Erase / Program Operations

Parameter		Description	Test Setup	Speed Options			Unit		
JEDEC	Std			70	90	100			
t_{AVAV}	t_{WC}	Write Cycle Time ¹	Min	70	90	100	ns		
t_{AVWL}	t_{AS}	Address Setup Time		0					
t_{WLAX}	t_{AH}	Address Hold Time		45					
t_{DVWH}	t_{DS}	Data Setup Time		35	45	55			
t_{WHDX}	t_{DH}	Data Hold Time		0					
	t_{OES}	Output Enable Setup Time		0					
t_{GHWL}	t_{GHWL}	Read Recovery Time Before Write, (OE# High to WE# Low)		0					
	t_{CS}	CE# Setup Time		0					
	t_{CHEH}	CE# Hold Time		0					
	t_{WLWH}	Write Pulse Width		35					
	t_{WHWL}	Write Pulse Width High		30					
	$t_{SR/W}$	Latency Between Read and Write Operations		20					
t_{WVWH1}	t_{WVWH1}	Programming Operation ²		Typ	5			μ s	
					Byte	7			
t_{WVWH2}	t_{WVWH2}	Sector Erase Operation ²	Min	0.7			sec		
	t_{VCS}	V_{CC} Setup Time ¹		50				μ s	
	t_{RB}	Recovery Time from RY / BY#		0					
	t_{BUSY}	Program / Erase Valid to RY / BY# Delay	Max	90			ns		

Notes:

- Not 100% Tested.
- See Erase and Programming Performance on page 38 for more information.

AC CHARACTERISTICS

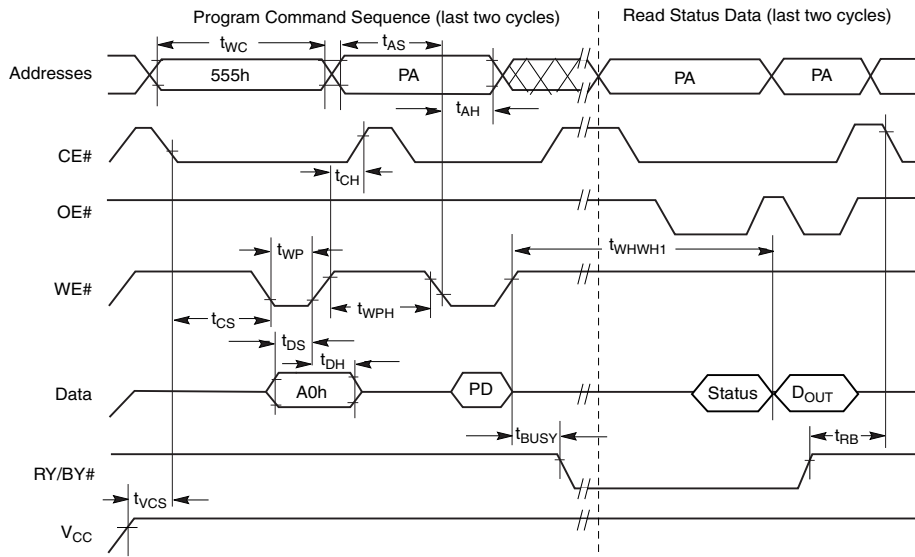

Notes:

1. PA = program address, PD = program data, D_{OUT} is the true data at the program address.
2. Illustration shows device in word mode.

Figure 16. Program Operation Timings

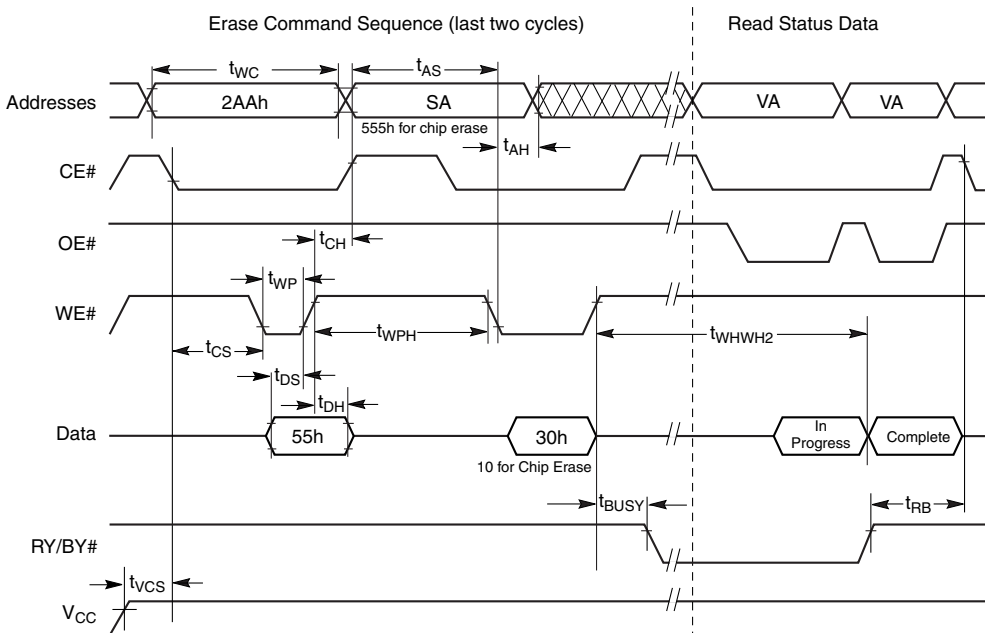

Notes:

1. SA = sector address (for Sector Erase), VA = Valid Address for reading status data (see Write Operation Status on page 22).
2. Illustration shows device in word mode.

Figure 17. Chip/Sector Erase Operation Timings



Austin Semiconductor, Inc.

**COTS PEM
BOOT SECTOR FLASH
AS29LV016**

AC CHARACTERISTICS

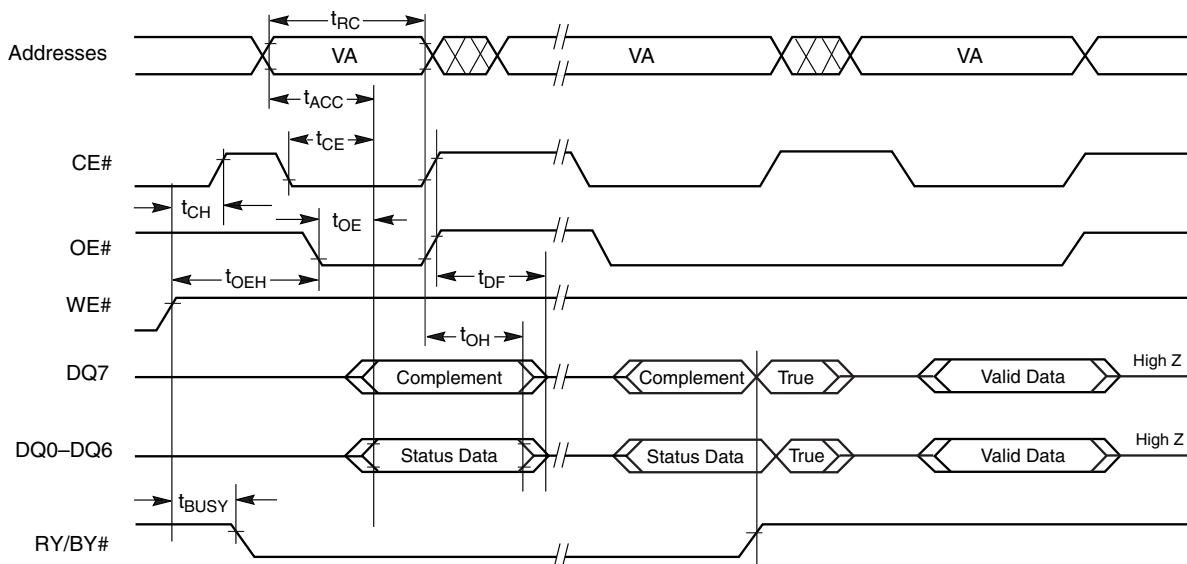

Note: VA = Valid address. Illustration shows first status cycle after command sequence, last status read cycle, and array data read cycle.

Figure 18. Data# Polling Timings (During Embedded Algorithms)

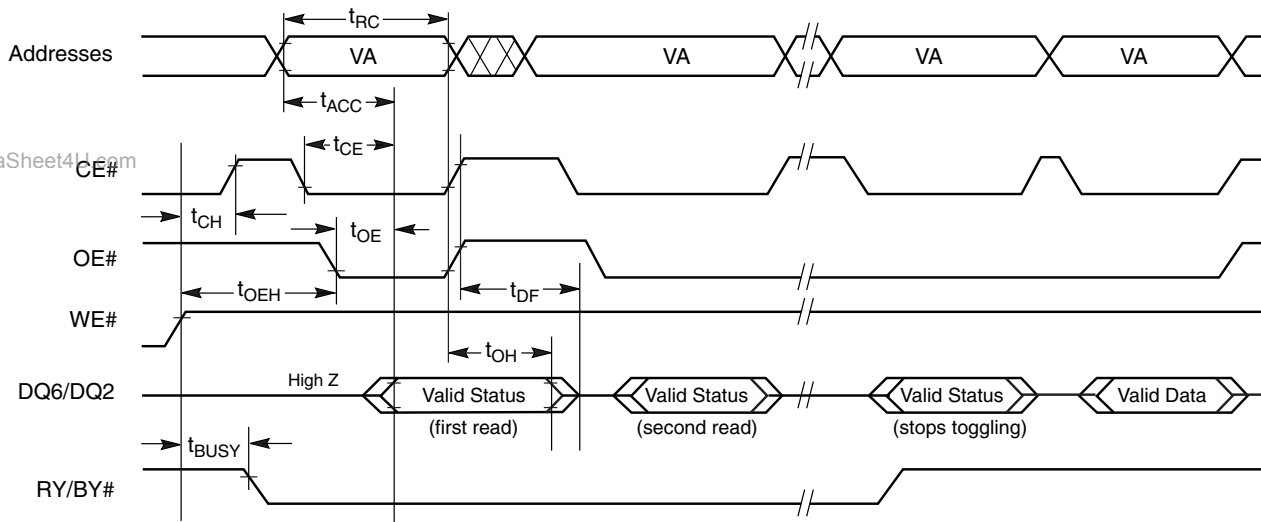

Note: VA = Valid address; not required for DQ6. Illustration shows first two status cycle after command sequence, last status read cycle, and array data read cycle.

Figure 19. Toggle Bit Timings (During Embedded Algorithms)



Austin Semiconductor, Inc.

**COTS PEM
BOOT SECTOR FLASH
AS29LV016**

AC CHARACTERISTICS

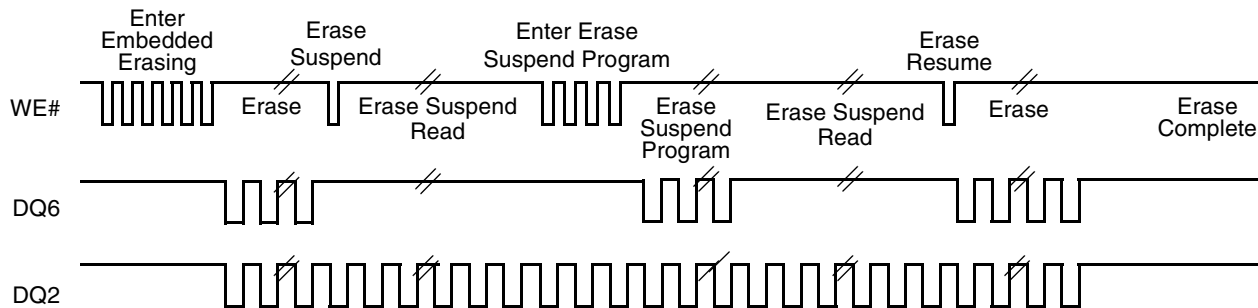

Note: The system may use CE# or OE# to toggle DQ2 and DQ6. DQ2 toggles only when read at an address within an erase-suspended sector.

Figure 20. DQ2 vs. DQ6 for Erase and Erase Suspend Operations

Temporary Sector Unprotect

Parameter		Description	Test Setup	All Speed Options	Unit
JEDEC	Std				
	t_{VIDR}	V_{ID} Rise and Fall Time ¹	Min	500	ns
	t_{RSP}	RESET# Setup Time for Temporary Sector Unprotect	Min	4	μ s

Note:

1. Not 100% Tested.

www.DataSheet4U.com

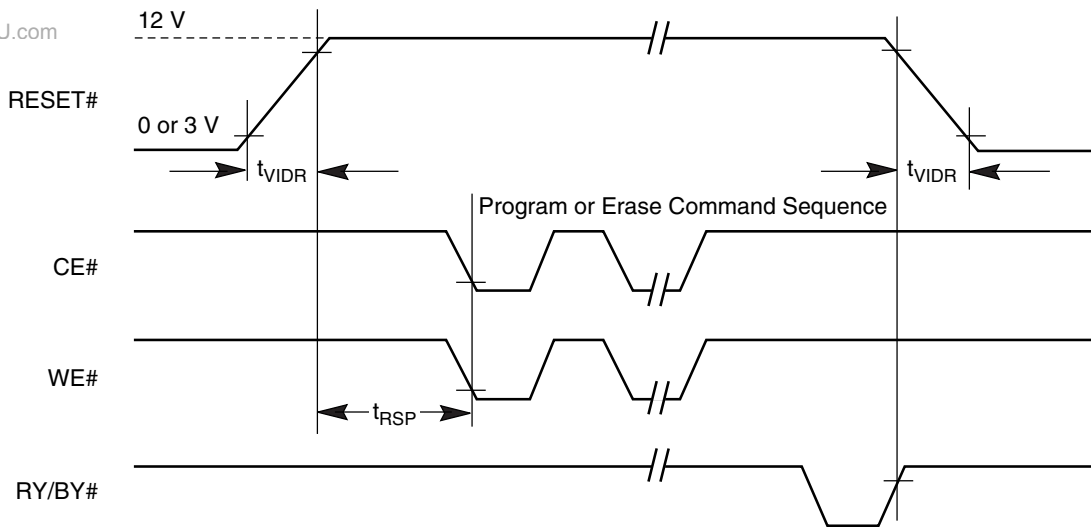

Figure 21. Temporary Sector Unprotect/Timing Diagram



Austin Semiconductor, Inc.

COTS PEM BOOT SECTOR FLASH AS29LV016

AC CHARACTERISTICS

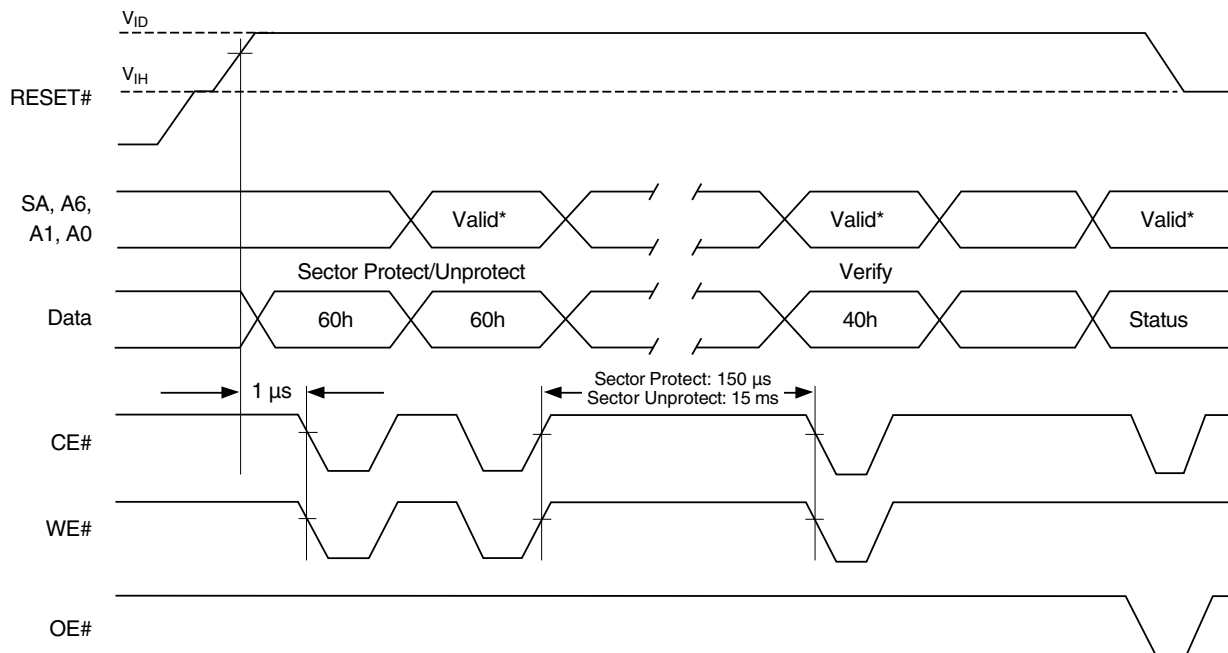

Note: For sector protect, A6 = 0, A1 = 1, A0 = 0. For sector unprotect, A6 = 1, A1 = 1, A0 = 0.

Figure 22. Sector Protect/Unprotect Timing Diagram

Alternate CE# Controlled Erase / Program Operations

Parameter		Description	Test Setup	Speed Options			Unit
JEDEC	Std			70	90	100	
t_{AVAV}	t_{WC}	Write Cycle Time ¹	Min	70	90	100	ns
t_{AVEL}	t_{AS}	Address Setup Time		0			
t_{ELAX}	t_{AH}	Address Hold Time		45	45	55	
t_{DVEH}	t_{DS}	Data Setup Time		35	45	55	
t_{EHDX}	t_{DH}	Data Hold Time		0			
	t_{OES}	Output Enable Setup Time		0			
t_{GHLEL}	t_{GHLEL}	Read Recovery Time Before Write, (OE# High to OE# Low)		0			
t_{WLLEL}	t_{WS}	WE# Setup Time		0			
t_{EHWH}	t_{WH}	WE# Hold Time		0			
t_{ELEH}	t_{CP}	CE# Pulse Width		35	35	40	
t_{EHEL}	t_{CPH}	CE# Pulse Width High		30			
	t_{SRW}	Latency Between Read and Write Operations		20			
t_{WHWH1}	t_{WHWH1}	Programming Operation ²		Typ	5		
		Byte	7				
t_{WHWH2}	t_{WHWH2}	Sector Erase Operation ²		0.7		sec	

Notes:

- Not 100% Tested.
- See Erase and Programming Performance on page 38 for more information.

AC CHARACTERISTICS

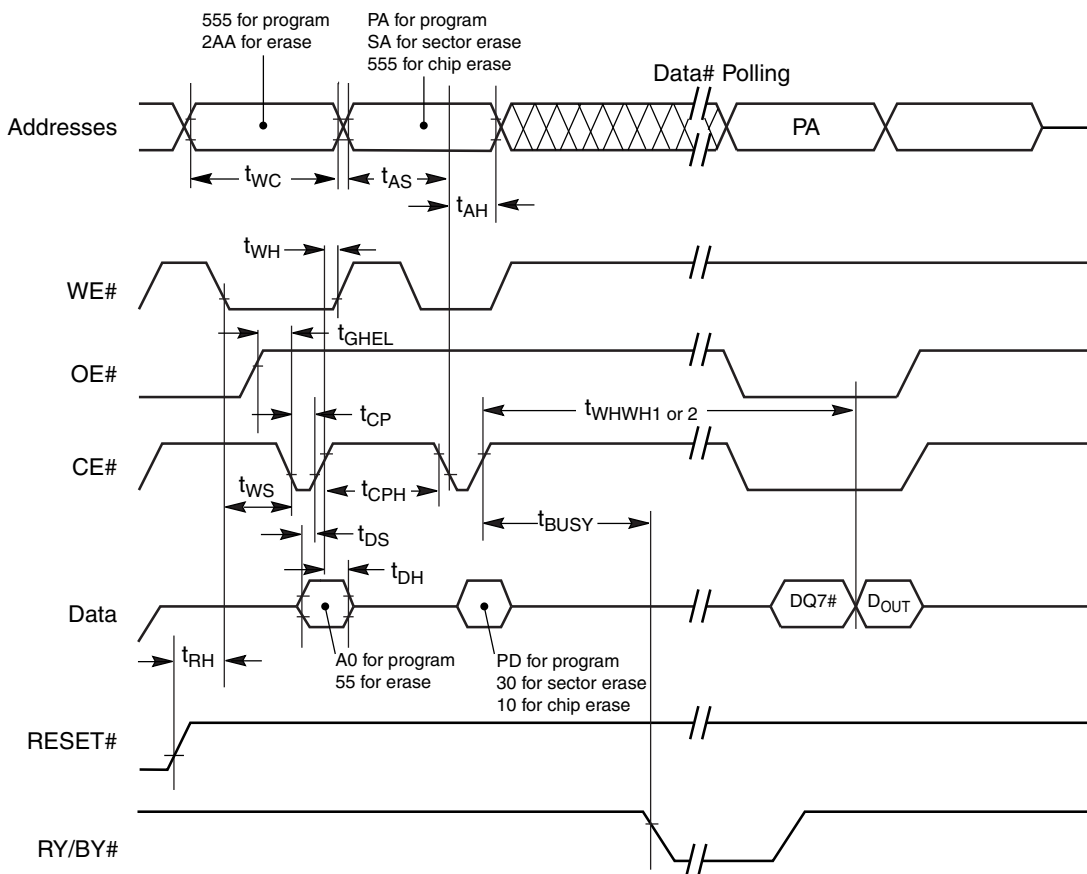

www.DataSheet4U.com

Notes:

1. PA = program address, PD = program data, DQ7# = complement of the data written to the device, D_{OUT} = data written to the device.
2. Figure indicates the last two bus cycles of the command sequence.
3. Word mode address used as an example.

Figure 23. Alternate CE# Controlled Write Operation Timings



Austin Semiconductor, Inc.

COTS PEM BOOT SECTOR FLASH AS29LV016

ERASE AND PROGRAMMING PERFORMANCE

Parameter	Typ ¹	Max ²	Unit	Comments
Sector Erase Time	0.7	10	s	Excludes 00h programming prior to erasure ⁴
Chip Erase Time	25		s	
Byte Programming Time	7	210	μs	Excludes system level overhead ⁵
Word Programming Time	7	210	μs	
Chip Programming Time ³	Byte Mode	11	33	
	Word Mode	7.2	21.6	s

Notes:

1. Typical program and erase times assume the following conditions: 25°C, $V_{CC} = 3.0$ V, 100,000 cycles, checkerboard data pattern.
2. Under worst case conditions of 90°C, $V_{CC} = 2.7$ V, 1,000,000 cycles.
3. The typical chip programming time is considerably less than the maximum chip programming time listed, since most bytes program faster than the maximum program times listed.
4. In the pre-programming step of the Embedded Erase algorithm, all bytes are programmed to 00h before erasure.
5. System-level overhead is the time required to execute the two- or four-bus-cycle sequence for the program command. See Table 9 on page 21 for further information on command definitions.
6. The device has a minimum erase and program cycle endurance of 100,000 cycles per sector.

TSOP, SO AND BGA PIN CAPACITANCE

Parameter Symbol	Parameter Description	Test Setup	Package	Typ	Max	Unit
C_{IN}	Input Capacitance	$V_{IN}=0$	TSOP, SO	6	7.5	pF
C_{OUT}	Output Capacitance	$V_{OUT}=0$	TSOP, SO	8.5	12	pF
C_{IN2}	Control Pin Capacitance	$V_{IN}=0$	TSOP, SO	7.5	9	pF

Notes:

1. Samples, not 100% tested.
2. Test conditions $T_A = 25^\circ$ C, $f = 1.0$ MHz



Austin Semiconductor, Inc.

**COTS PEM
BOOT SECTOR FLASH
AS29LV016**

PHYSICAL DIMENSIONS

TS 048—48-Pin Standard TSOP

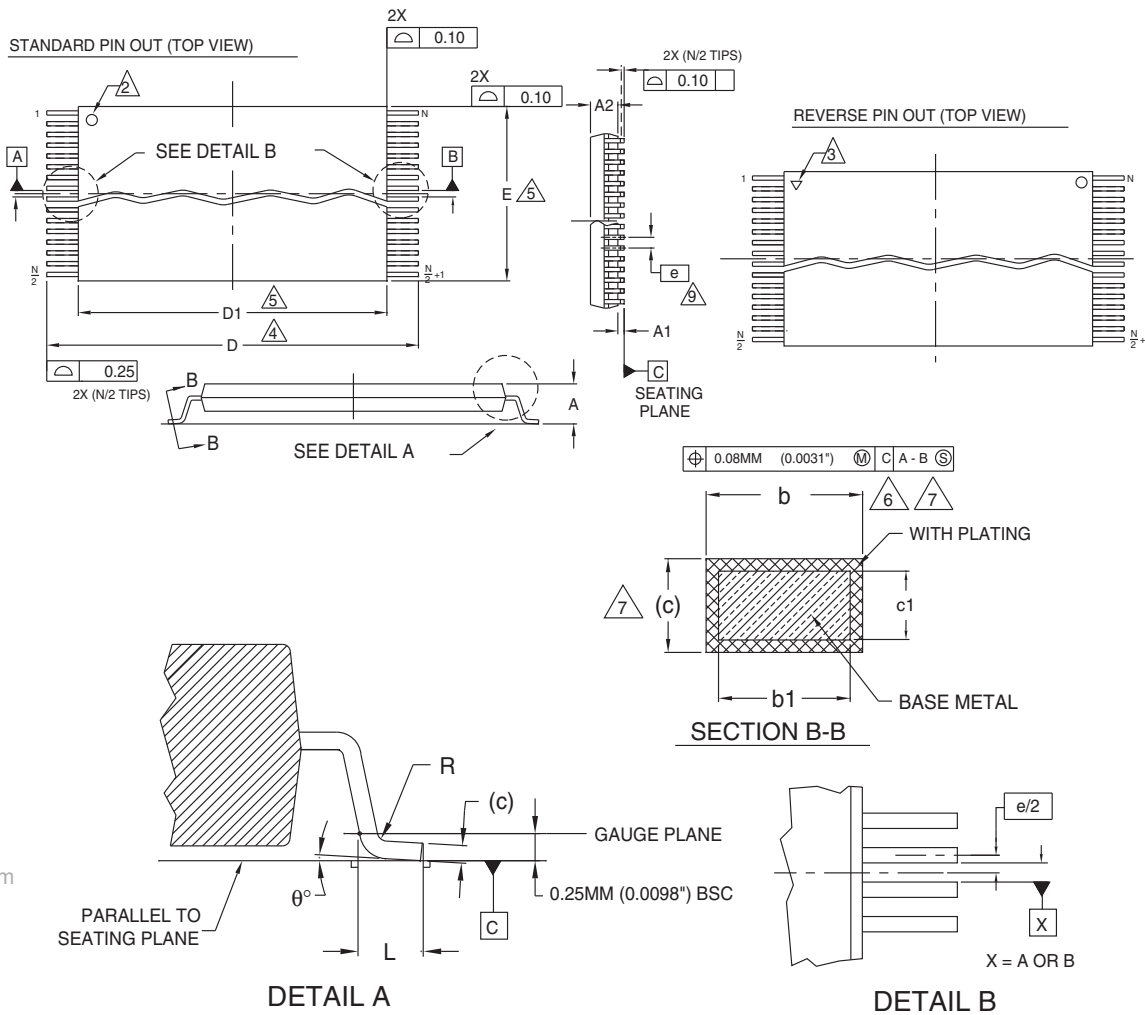

www.DataSheet4U.com

Jedec	MO-142 (D) DD		
Symbol	MIN	NOM	MAX
A	—	—	1.20
A1	0.05	—	0.15
A2	0.95	1.00	1.05
b1	0.17	0.20	0.23
b	0.17	0.22	0.27
c1	0.10	—	0.16
c	0.10	—	0.21
D	19.80	20.00	20.20
D1	18.30	18.40	18.50
E	11.90	12.00	12.10
e	0.50 BASIC		
L	0.50	0.60	0.70
theta	0°	—	8°
R	0.08	—	0.20
N	48		

NOTES:

- ① CONTROLLING DIMENSIONS ARE IN MILLIMETERS (mm). (DIMENSIONING AND TOLERANCING CONFORMS TO ANSI Y14.5M-1982)
- ② PIN 1 IDENTIFIER FOR REVERSE PIN OUT (DIE UP).
- ③ PIN 1 IDENTIFIER FOR REVERSE PIN OUT (DIE DOWN), INK OR LASER MARK.
- ④ TO BE DETERMINED AT THE SEATING PLANE [C-C], THE SEATING PLANE IS DEFINED AS THE PLANE OF CONTACT THAT IS MADE WHEN THE PACKAGE LEADS ARE ALLOWED TO REST FREELY ON A FLAT HORIZONTAL SURFACE.
- ⑤ DIMENSIONS D1 AND E DO NOT INCLUDE MOLD PROTRUSION. ALLOWABLE MOLD PROTRUSION IS 0.15mm (.0059") PER SIDE.
- ⑥ DIMENSION b DOES NOT INCLUDE DAMBAR PROTRUSION. ALLOWABLE DAMBAR PROTRUSION SHALL BE 0.08 (0.0031") TOTAL IN EXCESS OF b DIMENSION AT MAX. MATERIAL CONDITION. MINIMUM SPACE BETWEEN PROTRUSION AND AN ADJACENT LEAD TO BE 0.07 (0.0028").
- ⑦ THESE DIMENSIONS APPLY TO THE FLAT SECTION OF THE LEAD BETWEEN 0.10MM (.0039") AND 0.25MM (0.0098") FROM THE LEAD TIP.
- ⑧ LEAD COPLANARITY SHALL BE WITHIN 0.10mm (0.004") AS MEASURED FROM THE SEATING PLANE.
- ⑨ DIMENSION "e" IS MEASURED AT THE CENTERLINE OF THE LEADS.

3355 \ 16-038.10c



Austin Semiconductor, Inc.

COTS PEM
BOOT SECTOR FLASH
AS29LV016

DOCUMENT TITLE

16 Megabit (2M x 8-Bit / 1M x 16-Bit), CMOS 3.0 Volt-Only Boot Sector Flash Memory

REVISION HISTORY

<u>Rev #</u>	<u>History</u>	<u>Release Date</u>	<u>Status</u>
2.1	Added Pb-Free & Tape & Reel Option	October 2008	Release