



# VERY LOW POWER 1.8V 8K/4K x 16 DUAL-PORT STATIC RAM

**PRELIMINARY**  
**IDT70P257/247L**

## Features

- ◆ True Dual-Ported memory cells which allow simultaneous reads of the same memory location
- ◆ High-speed access
  - Industrial: 55ns (max.)
- ◆ Low-power operation
  - IDT70P257/247L
  - Active: 27mW (typ.)
  - Standby: 3.6μW (typ.)
- ◆ Separate upper-byte and lower-byte control for multiplexed bus compatibility
- ◆ IDT70P257/247 easily expands data bus width to 32 bits or more using the Master/Slave select when cascading more than one device
- ◆  $M/\overline{S} = V_{DD}$  for  $\overline{BUSY}$  output flag on Master
- ◆  $M/\overline{S} = V_{SS}$  for  $\overline{BUSY}$  input on Slave
- ◆ Input Read Register
- ◆ Output Drive Register
- ◆  $\overline{BUSY}$  and Interrupt Flag
- ◆ On-chip port arbitration logic
- ◆ Full on-chip hardware support of semaphore signaling between ports
- ◆ Fully asynchronous operation from either port
- ◆ LVTTTL-compatible, single 1.8V ( $\pm 100\text{mV}$ ) power supply
- ◆ Available in 100 Ball 0.5mm-pitch BGA
- ◆ Industrial temperature range ( $-40^{\circ}\text{C}$  to  $+85^{\circ}\text{C}$ )

## Functional Block Diagram

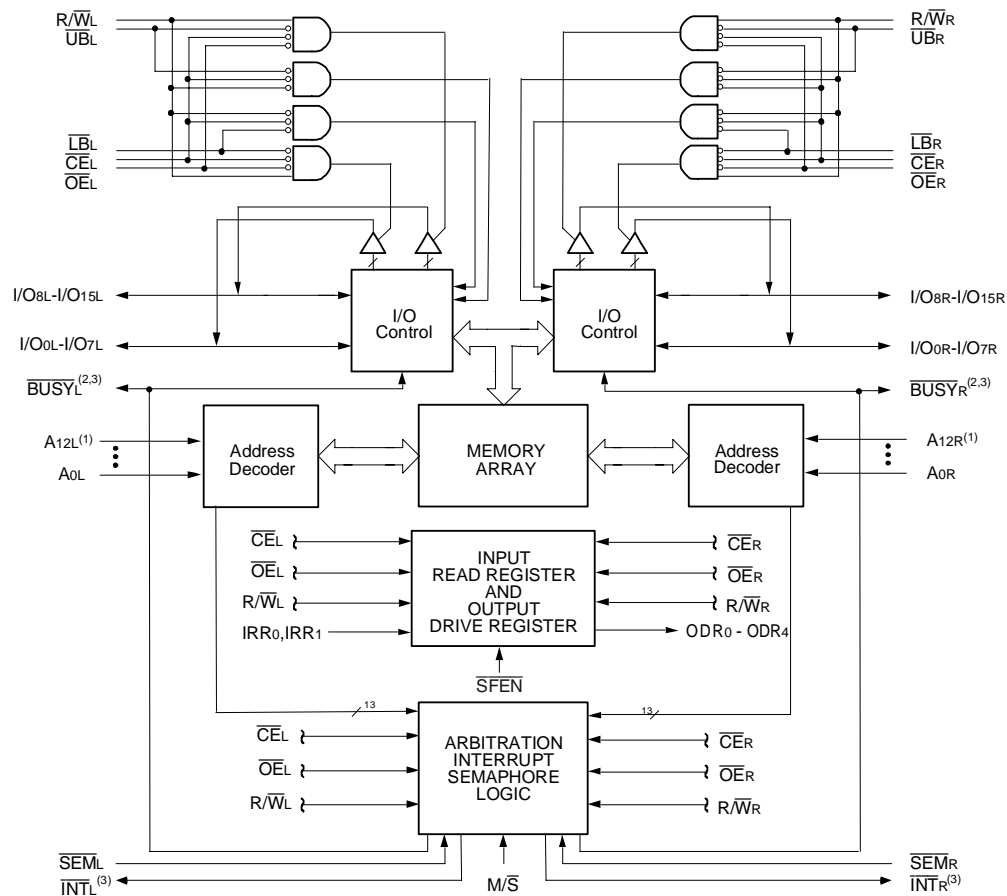

### NOTES:

1. A12x is a NC for IDT70P247.
2. (MASTER):  $\overline{BUSY}$  is output; (SLAVE):  $\overline{BUSY}$  is input.
3.  $\overline{BUSY}$  outputs and  $\overline{INT}$  outputs are non-tri-stated push-pull.

5684 drw 01

**FEBRUARY 2004**

## Description

The IDT70P257/247 is a very low power 8K/4K x 16 Dual-Port Static RAM. The IDT70P257/247 is designed to be used as a stand-alone 128/64K-bit Dual-Port SRAM or as a combination MASTER/SLAVE Dual-Port SRAM for 32-bit-or-more word systems. Using the IDT MASTER/SLAVE Dual-Port SRAM approach in 32-bit or wider memory system applications results in full-speed, error-free operation without the need for additional discrete logic.

This device provides two independent ports with separate control, address, and I/O pins that permit independent, asynchronous access for

reads or writes to any location in memory. An automatic power down feature controlled by  $\overline{CE}$  permits the on-chip circuitry of each port to enter a very low standby power mode.

Fabricated using IDT's CMOS high-performance technology, these devices typically operate on only 27mW of power.

The IDT70P257/247 is packaged in a 100 ball 0.5mm-pitch Ball Grid Array. The package is a 1 mm thick and designed to fit in wireless handset applications.

## Pin Configurations<sup>(2,3,4)</sup>

### 70P257/247BY BY-100

### 100-Ball 0.5mm Pitch BGA Top View<sup>(5)</sup>

02/04/04

A1 A5R	A2 A8R	A3 A11R	A4 $\overline{UBR}$	A5 VSS	A6 $\overline{SEMR}$	A7 I/O15R	A8 I/O12R	A9 I/O10R	A10 VSS
B1 A3R	B2 A4R	B3 A7R	B4 A9R	B5 $\overline{CER}$	B6 R/ $\overline{WR}$	B7 $\overline{OER}$	B8 VDD	B9 I/O9R	B10 I/O6R
C1 A0R	C2 A1R	C3 A2R	C4 A6R	C5 $\overline{LBR}$	C6 IRR1	C7 I/O14R	C8 I/O11R	C9 I/O7R	C10 VSS
D1 ODR4	D2 ODR2	D3 $\overline{BUSYR}$	D4 $\overline{INTR}$	D5 A10R	D6 A12R <sup>(1)</sup>	D7 I/O13R	D8 I/O8R	D9 I/O5R	D10 I/O2R
E1 VSS	E2 M/ $\overline{S}$	E3 ODR3	E4 $\overline{INTL}$	E5 VSS	E6 VSS	E7 I/O4R	E8 VDD	E9 I/O1R	E10 VSS
F1 $\overline{SFEN}$	F2 ODR1	F3 $\overline{BUSYL}$	F4 A1L	F5 VDD	F6 VSS	F7 I/O3R	F8 I/O0R	F9 I/O15L	F10 VDD
G1 ODR0	G2 A2L	G3 A5L	G4 A12L <sup>(1)</sup>	G5 $\overline{OEL}$	G6 I/O3L	G7 I/O11L	G8 I/O12L	G9 I/O14L	G10 I/O13L
H1 A0L	H2 A4L	H3 A9L	H4 $\overline{LBL}$	H5 $\overline{CEL}$	H6 I/O1L	H7 VDD	H8 NC	H9 NC	H10 I/O10L
J1 A3L	J2 A7L	J3 A10L	J4 IRR0	J5 VDD	J6 VSS	J7 I/O4L	J8 I/O6L	J9 I/O8L	J10 I/O9L
K1 A6L	K2 A8L	K3 A11L	K4 $\overline{UBL}$	K5 $\overline{SEML}$	K6 R/ $\overline{WL}$	K7 I/O0L	K8 I/O2L	K9 I/O5L	K10 I/O7L

5684 drw 02b

#### NOTES:

1. A12x is a NC for IDT70P247.
2. All VDD pins must be connected to power supply.
3. All VSS pins must be connected to ground supply.
4. BY100-1 package body is approximately 6mm x 6mm x 1mm, ball pitch 0.5mm.
5. This package code is used to reference the package diagram.
6. This text does not indicate orientation of the actual part-marking.

## Pin Names

Left Port	Right Port	Names
$\overline{CE}_L$	$\overline{CE}_R$	Chip Enable (Input)
$R/\overline{WL}$	$R/\overline{WR}$	Read/Write Enable (Input)
$\overline{OE}_L$	$\overline{OE}_R$	Output Enable (Input)
A <sub>0L</sub> - A <sub>12L</sub> <sup>(1)</sup>	A <sub>0R</sub> - A <sub>12R</sub> <sup>(1)</sup>	Address (Input)
I/O <sub>0L</sub> - I/O <sub>15L</sub>	I/O <sub>0R</sub> - I/O <sub>15R</sub>	Data Input/Output
$\overline{SEM}_L$	$\overline{SEM}_R$	Semaphore Enable (Input)
$\overline{UB}_L$	$\overline{UB}_R$	Upper Byte Select (Input)
$\overline{LB}_L$	$\overline{LB}_R$	Lower Byte Select (Input)
$\overline{INT}_L$	$\overline{INT}_R$	Interrupt Flag (Output)
$\overline{BUSY}_L$	$\overline{BUSY}_R$	Busy Flag
IRR <sub>0</sub> , IRR <sub>1</sub>		Input Read Register (Input)
ODR <sub>0</sub> - ODR <sub>4</sub>		Output Drive Register (Output)
$\overline{SFEN}$ <sup>(2)</sup>		Special Function Enable (Input)
M/ $\overline{S}$		Master or Slave Select (Input)
VDD		Power (1.8V) (Input)
VSS		Ground (0V) (Input)

**NOTE:**

1. A<sub>12x</sub> is a NC for IDT70P247.
2.  $\overline{SFEN}$  is active when either  $\overline{CE}_L = V_{IL}$  or  $\overline{CE}_R = V_{IL}$ .  
 $\overline{SFEN}$  is inactive when  $\overline{CE}_L = \overline{CE}_R = V_{IH}$ .

5684 tbl 01

## Truth Table I: Non-Contention Read/Write Control

Inputs <sup>(1)</sup>						Outputs		Mode
$\overline{CE}$	$R/\overline{W}$	$\overline{OE}$	$\overline{UB}$	$\overline{LB}$	$\overline{SEM}$	I/O <sub>8-15</sub>	I/O <sub>0-7</sub>	
H	X	X	X	X	H	High-Z	High-Z	Deselected: Power Down
X	X	X	H	H	H	High-Z	High-Z	Both Bytes Deselected
L	L	X	L	H	H	DATA <sub>IN</sub>	High-Z	Write to Upper Byte Only
L	L	X	H	L	H	High-Z	DATA <sub>IN</sub>	Write to Lower Byte Only
L	L	X	L	L	H	DATA <sub>IN</sub>	DATA <sub>IN</sub>	Write to Both Bytes
L	H	L	L	H	H	DATA <sub>OUT</sub>	High-Z	Read Upper Byte Only
L	H	L	H	L	H	High-Z	DATA <sub>OUT</sub>	Read Lower Byte Only
L	H	L	L	L	H	DATA <sub>OUT</sub>	DATA <sub>OUT</sub>	Read Both Bytes
X	X	H	X	X	X	High-Z	High-Z	Outputs Disabled

**NOTE:**

1. A<sub>0L</sub> — A<sub>12L</sub> ≠ A<sub>0R</sub> — A<sub>12R</sub> for IDT70P257; A<sub>0L</sub> — A<sub>11L</sub> ≠ A<sub>0R</sub> — A<sub>11R</sub> for IDT70P247.

5684 tbl 02

## Truth Table II: Semaphore Read/Write Control<sup>(1)</sup>

Inputs						Outputs		Mode
$\overline{CE}$	R/W	$\overline{OE}$	$\overline{UB}$	$\overline{LB}$	$\overline{SEM}$	I/O <sub>8-15</sub>	I/O <sub>0-7</sub>	
H	H	L	X	X	L	DATA <sub>OUT</sub>	DATA <sub>OUT</sub>	Read Data in Semaphore Flag
X	H	L	H	H	L	DATA <sub>OUT</sub>	DATA <sub>OUT</sub>	Read Data in Semaphore Flag
H	↑	X	X	X	L	DATA <sub>IN</sub>	DATA <sub>IN</sub>	Write D <sub>IN0</sub> into Semaphore Flag
X	↑	X	H	H	L	DATA <sub>IN</sub>	DATA <sub>IN</sub>	Write D <sub>IN0</sub> into Semaphore Flag
L	X	X	L	X	L	—	—	Not Allowed
L	X	X	X	L	L	—	—	Not Allowed

5684 tbl 03

### NOTE:

- There are eight semaphore flags written to via I/O<sub>0</sub> and read from all of the I/O's (I/O<sub>0</sub>-I/O<sub>15</sub>). These eight semaphores are addressed by A<sub>0</sub>-A<sub>2</sub>.

## Absolute Maximum Ratings<sup>(1)</sup>

Symbol	Rating	Industrial	Unit
V <sub>TERM</sub> <sup>(2)</sup>	Terminal Voltage with Respect to GND	-0.5 to V <sub>DDMAX</sub> +0.3V	V
T <sub>BIAS</sub> <sup>(3)</sup>	Temperature Under Bias	-55 to +125	°C
T <sub>STG</sub>	Storage Temperature	-65 to +150	°C
T <sub>JN</sub>	Junction Temperature	+150	°C
I <sub>OUT</sub>	DC Output Current	20	mA

5684 tbl 04

### NOTES:

- Stresses greater than those listed under ABSOLUTE MAXIMUM RATINGS may cause permanent damage to the device. This is a stress rating only and functional operation of the device at these or any other conditions above those indicated in the operational sections of this specification is not implied. Exposure to absolute maximum rating conditions for extended periods may affect reliability.
- V<sub>TERM</sub> must not exceed V<sub>DD</sub> + 0.3V for more than 25% of the cycle time or 10ns maximum, and is limited to ≤ 20mA for the period over V<sub>TERM</sub> = V<sub>DD</sub> + 0.3V.
- Ambient Temperature under DC Bias. No AC Conditions. Chip Deselected.

### Capacitance (TA = +25°C, f = 1.0MHz)

Symbol	Parameter	Conditions <sup>(2)</sup>	Max.	Unit
CIN	Input Capacitance	VIN = 3dV	9	pF
COUT	Output Capacitance	VOU = 3dV	11	pF

5684 tbl 07

**NOTES:**

1. This parameter is determined by device characterization but is not production tested.
2. 3dV references the interpolated capacitance when the input and output signals switch from 0V to 3V or from 3V to 0V.

### Maximum Operating Temperature and Supply Voltage<sup>(1)</sup>

Grade	Ambient Temperature	GND	VDD
Industrial	-40°C to +85°C	0V	1.8V ± 100mV

5684 tbl 05

**NOTES:**

1. This is the parameter TA. This is the "instant on" case temperature.

### Recommended DC Operating Conditions

Symbol	Parameter	Min.	Typ.	Max.	Unit
VDD	Supply Voltage <sup>(3)</sup>	1.7	1.8	1.9	V
VSS	Ground	0	0	0	V
VIH	Input High Voltage	1.2	—	VDD + 0.2	V
VIL	Input Low Voltage	-0.2	—	0.4	V

5684 tbl 06

**NOTES:**

1. VIL ≥ -1.5V for pulse width less than 10ns.
2. VTERM must not exceed VDD + 0.3V.
3. M/S operates at the VDD and VSS voltage levels.

### DC Electrical Characteristics Over the Operating Temperature and Supply Voltage Range ( $V_{DD} = 1.8V \pm 100mV$ )

Symbol	Parameter	Test Conditions	Min.	Max.	Unit
I <sub>LI</sub>	Input Leakage Current	$V_{DD} = 1.8V, V_{IN} = 0V$ to $V_{DD}$	—	1	$\mu A$
I <sub>LO</sub>	Output Leakage Current	$\overline{CE} = V_{IH}, V_{OUT} = 0V$ to $V_{DD}$	—	1	$\mu A$
V <sub>OL</sub>	Output Low Voltage	I <sub>OL</sub> = +0.1mA	—	0.2	V
V <sub>OH</sub>	Output High Voltage	I <sub>OH</sub> = -0.1mA	$V_{DD} - 0.2V$	—	V

5684 tbl 08

### DC Electrical Characteristics Over the Operating Temperature and Supply Voltage Range<sup>(1)</sup> ( $V_{DD} = 1.8V \pm 100mV$ )

Symbol	Parameter	Test Condition	Version	70P257/247 Ind'l Only		Unit
				Typ. <sup>(1)</sup>	Max.	
I <sub>DD</sub>	Dynamic Operating Current (Both Ports Active)	$\overline{CE} = V_{IL}$ , Outputs Open $f = f_{MAX}^{(2)}$	IND'L L	15	25	mA
I <sub>SB1</sub>	Standby Current (Both Ports - TTL Level Inputs)	$\overline{CE}_R$ and $\overline{CE}_L = V_{IH}$ , $\overline{SEM} = V_{IH}$ $f = f_{MAX}^{(2)}$	IND'L L	2	8	$\mu A$
I <sub>SB2</sub>	Standby Current (One Port - TTL Level Inputs)	$\overline{CE}^{*A} = V_{IL}$ and $\overline{CE}^{*B} = V_{IH}^{(4)}$ , Active Port Outputs Open $f = f_{MAX}^{(2)}$	IND'L L	8.5	14	mA
I <sub>SB3</sub>	Full Standby Current (Both Ports - CMOS Level Inputs)	Both Ports $\overline{CE}_L$ and $\overline{CE}_R \geq V_{DD} - 0.2V$ , $\overline{SEM}_L$ and $\overline{SEM}_R \geq V_{DD} - 0.2V$ , $V_{IN} \geq V_{DD} - 0.2V$ or $V_{IN} \leq 0.2V$ $f = f_{MAX}^{(2)}$ , $M/\overline{S} = V_{DD}$ or $V_{SS}^{(4)}$	IND'L L	2	8	$\mu A$
I <sub>SB4</sub>	Full Standby Current (One Port - CMOS Level Inputs)	$\overline{CE}^{*A} \leq 0.2V$ and $\overline{CE}^{*B} \geq V_{DD} - 0.2V^{(4)}$ $V_{IN} \geq V_{DD} - 0.2V$ or $V_{IN} \leq 0.2V$ , Active Port Outputs Open $f = f_{MAX}^{(2)}$	IND'L L	8.5	14	mA

5684 tbl 09

**NOTES:**

- $V_{DD} = 1.8V$ ,  $T_A = +25^\circ C$ , and are not production tested. I<sub>DD DC</sub> = 15mA (typ.)
- At  $f = f_{MAX}$ , address and control lines are cycling at the maximum frequency read cycle of 1/t<sub>RC</sub>, and using "AC Test Conditions".
- Port "A" may be either left or right port. Port "B" is the opposite from port "A".
- If  $M/\overline{S} = V_{SS}$ , then  $f_{BUSYL} = f_{BUSYR} = 0$  for full standby mode.

### AC Test Conditions

Input Pulse Levels	GND to 1.8V
Input Rise/Fall Times	3ns Max.
Input Timing Reference Levels	0.9V
Output Reference Levels	0.9V
Output Load	Figure 1

5684 tbl 10

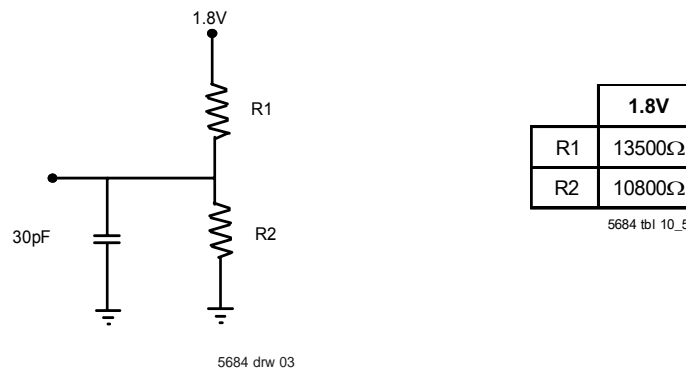
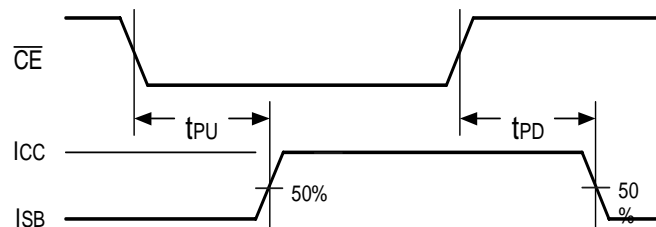

Figure 1. AC Output Test Load  
 (5pF for tLZ, tHZ, tWZ, tOW)

### Timing of Power-Up Power-Down



5684 drw 04

## AC Electrical Characteristics Over the Operating Temperature and Supply Voltage Range<sup>(4)</sup>

Symbol	Parameter	70P257/247 Ind'l Only		Unit
		Min.	Max.	
<b>READ CYCLE</b>				
t <sub>RC</sub>	Read Cycle Time	55	—	ns
t <sub>AA</sub>	Address Access Time	—	55	ns
t <sub>ACE</sub>	Chip Enable Access Time <sup>(3)</sup>	—	55	ns
t <sub>ABE</sub>	Byte Enable Access Time <sup>(3)</sup>	—	55	ns
t <sub>AOE</sub>	Output Enable Access Time <sup>(3)</sup>	—	30	ns
t <sub>OH</sub>	Output Hold from Address Change	5	—	ns
t <sub>LZ</sub>	Output Low-Z Time <sup>(1,2,5)</sup>	5	—	ns
t <sub>HZ</sub>	Output High-Z Time <sup>(1,2,5)</sup>	—	25	ns
t <sub>PU</sub>	Chip Enable to Power Up Time <sup>(1,2)</sup>	0	—	ns
t <sub>PD</sub>	Chip Disable to Power Down Time <sup>(1,2)</sup>	—	55	ns
t <sub>SOP</sub>	Semaphore Flag Update Pulse ( $\overline{OE}$ or $\overline{SEM}$ )	15	—	ns
t <sub>SAA</sub>	Semaphore Address Access <sup>(3)</sup>	—	55	ns

**NOTES:**

5684 tbl 11

1. Transition is measured 0mV from Low or High-impedance voltage with Output Test Load.
2. This parameter is guaranteed by device characterization, but is not production tested.
3. To access RAM,  $\overline{CE} = V_{IL}$ ,  $\overline{UB}$  or  $\overline{LB} = V_{IL}$ , and  $\overline{SEM} = V_{IH}$ . To access semaphore,  $\overline{CE} = V_{IH}$  or  $\overline{UB}$  and  $\overline{LB} = V_{IH}$ , and  $\overline{SEM} = V_{IL}$ .
4. The specification for t<sub>OH</sub> must be met by the device supplying write data to the SRAM under all operating conditions. Although t<sub>OH</sub> and t<sub>OW</sub> values will vary over voltage and temperature, the actual t<sub>OH</sub> will always be smaller than the actual t<sub>OW</sub>.
5. At any given temperature and voltage condition, t<sub>HZ</sub> is less than t<sub>LZ</sub> for any given device.



### Waveform of Read Cycles<sup>(5)</sup>

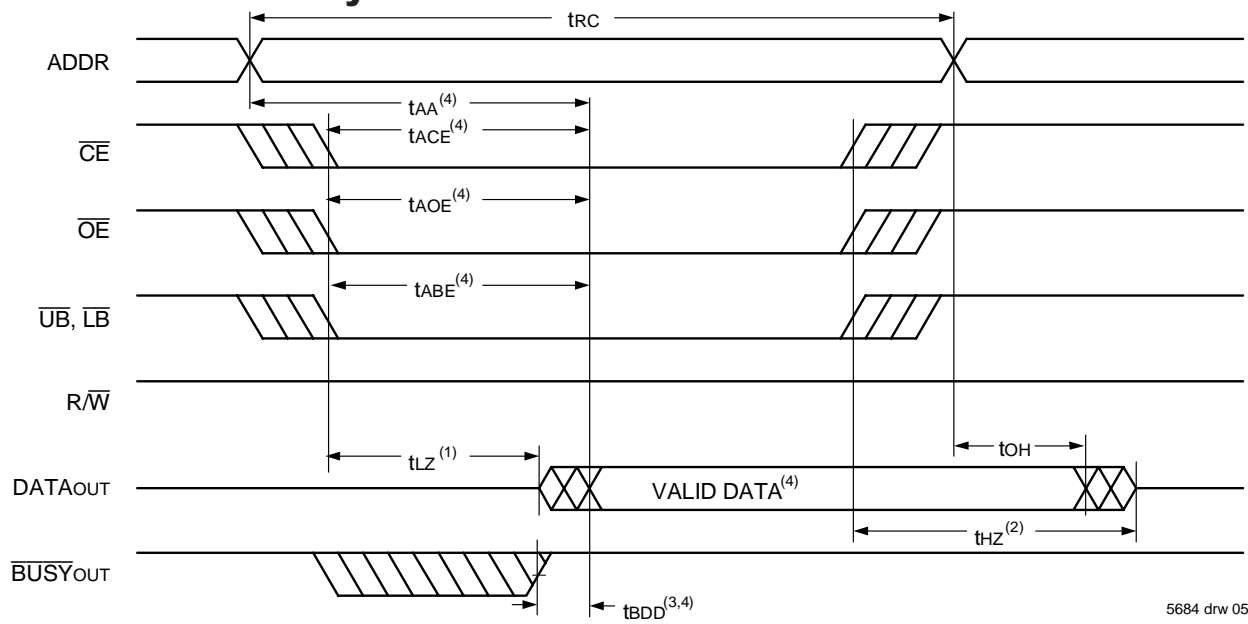

5684 drw 05

**NOTES:**

1. Timing depends on which signal is asserted last,  $\overline{OE}$ ,  $\overline{CE}$ ,  $\overline{LB}$ , or  $\overline{UB}$ .
2. Timing depends on which signal is de-asserted first  $\overline{CE}$ ,  $\overline{OE}$ ,  $\overline{LB}$ , or  $\overline{UB}$ .
3.  $t_{BDD}$  delay is required only in cases where opposite port is completing a write operation to the same address location. For simultaneous read operations  $\overline{BUSY}$  has no relation to valid output data.
4. Start of valid data depends on which timing becomes effective last  $t_{ABE}$ ,  $t_{AOE}$ ,  $t_{ACE}$ ,  $t_{AA}$  or  $t_{BDD}$ .
5.  $\overline{SEM} = V_{IH}$ .

## AC Electrical Characteristics Over the Operating Temperature and Supply Voltage<sup>(4)</sup>

Symbol	Parameter	70P257/247 Ind'l Only		Unit
		Min.	Max.	
<b>WRITE CYCLE</b>				
t <sub>WC</sub>	Write Cycle Time	55	—	ns
t <sub>EW</sub>	Chip Enable to End-of-Write <sup>(3)</sup>	45	—	ns
t <sub>AW</sub>	Address Valid to End-of-Write	45	—	ns
t <sub>AS</sub>	Address Set-up Time <sup>(3)</sup>	0	—	ns
t <sub>WP</sub>	Write Pulse Width	40	—	ns
t <sub>WR</sub>	Write Recovery Time	0	—	ns
t <sub>DW</sub>	Data Valid to End-of-Write	30	—	ns
t <sub>HZ</sub>	Output High-Z Time <sup>(1,2)</sup>	—	25	ns
t <sub>DH</sub>	Data Hold Time <sup>(4)</sup>	0	—	ns
t <sub>WZ</sub>	Write Enable to Output in High-Z <sup>(1,2)</sup>	—	25	ns
t <sub>OW</sub>	Output Active from End-of-Write <sup>(1,2,4)</sup>	0	—	ns
t <sub>SWRD</sub>	SEM Flag Write to Read Time	10	—	ns
t <sub>SPS</sub>	SEM Flag Contention Window	10	—	ns

5684 tbl 12

**NOTES:**

1. Transition is measured 0mV from Low or High-impedance voltage with Output Test Load.
2. This parameter is guaranteed by device characterization, but is not production tested.
3. To access SRAM,  $\overline{CE} = V_{IL}$ ,  $\overline{UB}$  or  $\overline{LB} = V_{IL}$ ,  $\overline{SEM} = V_{IH}$ . To access semaphore,  $\overline{CE} = V_{IH}$  or  $\overline{UB}$  and  $\overline{LB} = V_{IH}$  and  $\overline{SEM} = V_{IL}$ . Either condition must be valid for the entire t<sub>EW</sub> time.
4. The specification for t<sub>DH</sub> must be met by the device supplying write data to the SRAM under all operating conditions. Although t<sub>DH</sub> and t<sub>OW</sub> values will vary over voltage and temperature, the actual t<sub>DH</sub> will always be smaller than the actual t<sub>OW</sub>.

### Timing Waveform of Write Cycle No. 1, R/W Controlled Timing<sup>(1,5,8)</sup>

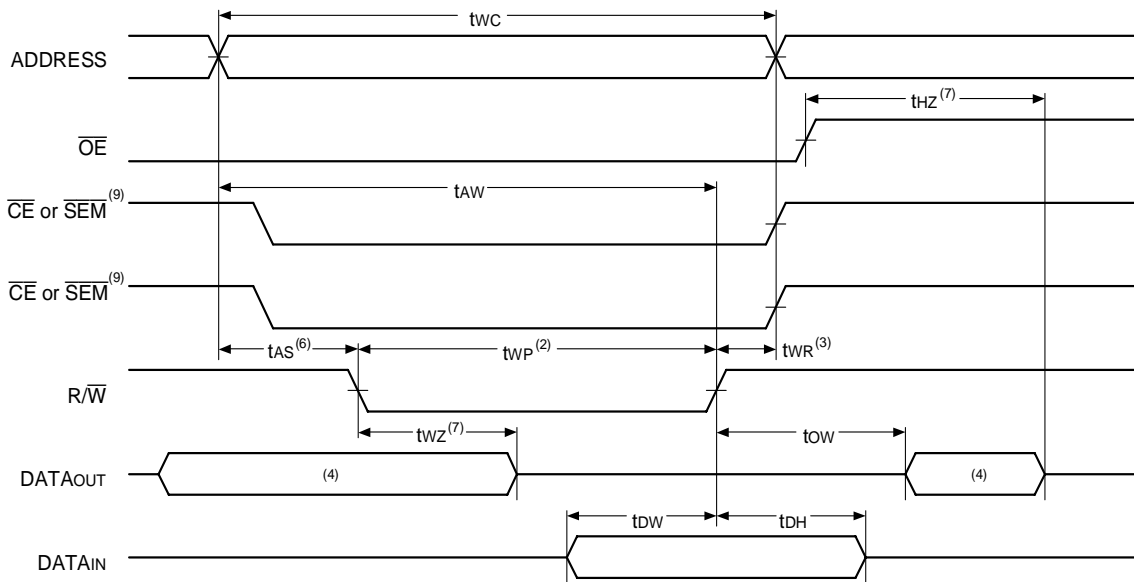

5684 drw 06

### Timing Waveform of Write Cycle No. 2, CE, UB, LB Controlled Timing<sup>(1,5)</sup>

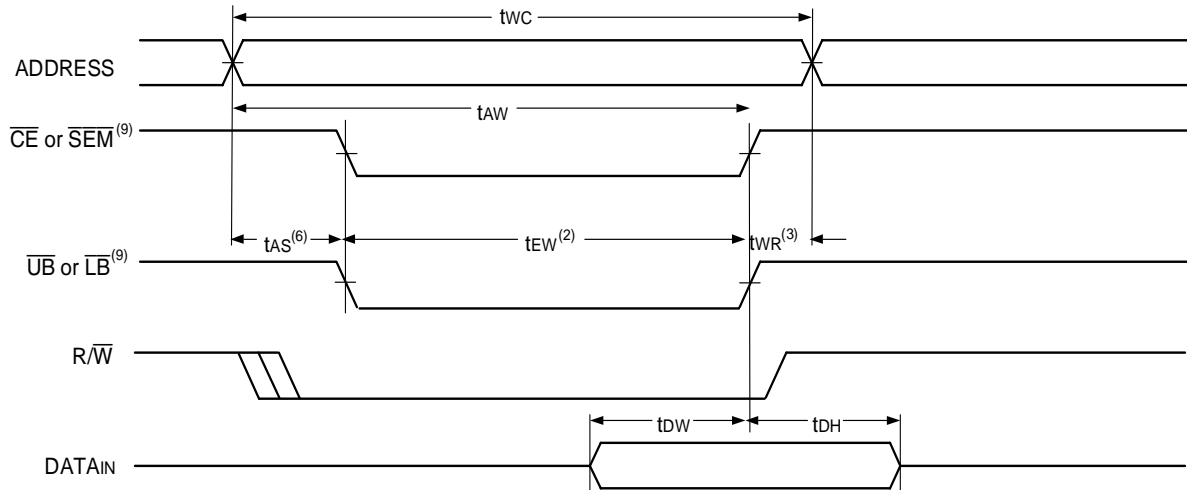

5684 drw 07

NOTES:

1. R/W or CE or UB & LB must be high during all address transitions.
2. A write occurs during the overlap (tew or twp) of a low UB or LB and a LOW CE and a LOW R/W for memory array writing cycle.
3. tWR is measured from the earlier of CE or R/W going HIGH (or SEM going LOW) to the end of write cycle.
4. During this period, the I/O pins are in the output state and input signals must not be applied.
5. If the CE or SEM LOW transition occurs simultaneously with or after the R/W LOW transition, the outputs remain in the high-impedance state.
6. Timing depends on which enable signal is asserted last, CE, R/W or byte control.
7. This parameter is guaranteed by device characterization, but is not production tested. Transition is measured 0mV from low or high-impedance voltage with Output Test Load.
8. If OE is LOW during R/W controlled write cycle, the write pulse width must be the larger of twp or (twz + tow) to allow the I/O drivers to turn off and data to be placed on the bus for the required tdw. If OE is HIGH during an R/W controlled write cycle, this requirement does not apply and the write pulse can be as short as the specified twp.
9. To access SRAM, CE = VIL, UB or LB = VIL, SEM = VIH. To access semaphore, CE = VIH or UB and LB = VIH and SEM = VIL. Either condition must be valid for the entire tew time.

### Timing Waveform of Semaphore Read after Write Timing, Either Side<sup>(1)</sup>

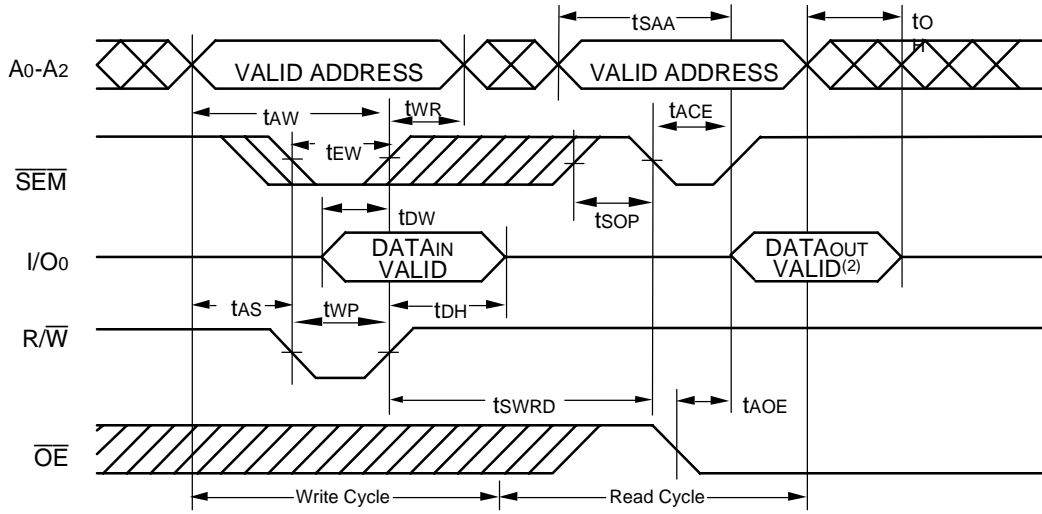

**NOTES:**

1.  $\overline{CE} = V_{IH}$  or  $\overline{UB} \& \overline{LB} = V_{IH}$  for the duration of the above timing (both write and read cycle).
2. "DATAOUT VALID" represents all I/O's (I/O<sub>0</sub>-I/O<sub>15</sub>) equal to the semaphore value.

5684 drw 08

### Timing Waveform of Semaphore Write Contention<sup>(1,3,4)</sup>

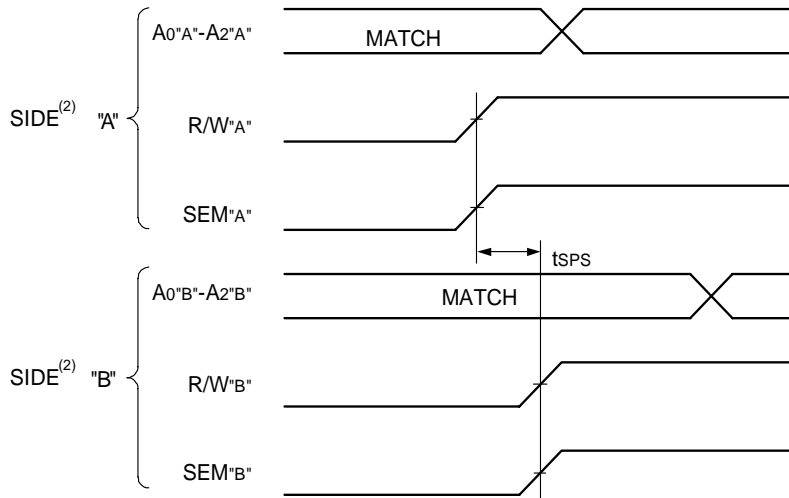

5684 drw 09

**NOTES:**

1.  $D_{OR} = D_{OL} = V_{IL}$ ,  $\overline{CE}_R = \overline{CE}_L = V_{IH}$ , or Both  $\overline{UB} \& \overline{LB} = V_{IH}$ .
2. All timing is the same for left or right port. "A" may be either left or right port. "B" is the opposite port from "A".
3. This parameter is measured from  $R/\overline{W}^A$  or  $\overline{SEM}^A$  going HIGH to  $R/\overline{W}^B$  or  $\overline{SEM}^B$  going HIGH.
4. If tSPS is not satisfied there is no guarantee which side will be granted the semaphore flag.

## AC Electrical Characteristics Over the Operating Temperature and Supply Voltage Range

Symbol	Parameter	70P257/247 Ind'l Only		Unit
		Min.	Max.	
<b>BUSY TIMING (<math>M/\bar{S} = V_{DD}</math>)</b>				
t <sub>BAA</sub>	$\overline{BUSY}$ Access Time from Address Match	—	45	ns
t <sub>BDA</sub>	$\overline{BUSY}$ Disable Time from Address Not Matched	—	45	ns
t <sub>BAC</sub>	$\overline{BUSY}$ Access Time from Chip Enable LOW	—	45	ns
t <sub>BDC</sub>	$\overline{BUSY}$ Disable Time from Chip Enable HIGH	—	45	ns
t <sub>APS</sub>	Arbitration Priority Set-up Time <sup>(2)</sup>	5	—	ns
t <sub>BDD</sub>	$\overline{BUSY}$ Disable to Valid Data <sup>(3)</sup>	—	40	ns
t <sub>WH</sub>	Write Hold After $\overline{BUSY}$ <sup>(5)</sup>	35	—	ns
<b>BUSY TIMING (<math>M/\bar{S} = V_{SS}</math>)</b>				
t <sub>WB</sub>	$\overline{BUSY}$ Input to Write <sup>(4)</sup>	0	—	ns
t <sub>WH</sub>	Write Hold After $\overline{BUSY}$ <sup>(5)</sup>	35	—	ns
<b>PORT-TO-PORT DELAY TIMING</b>				
t <sub>WDD</sub>	Write Pulse to Data Delay <sup>(1)</sup>	—	80	ns
t <sub>DDD</sub>	Write Data Valid to Read Data Delay <sup>(1)</sup>	—	65	ns

5684 tbl 13

**NOTES:**

1. Port-to-port delay through SRAM cells from writing port to reading port, refer to "Timing Waveform of Read With  $\overline{BUSY}$  ( $M/\bar{S} = V_{DD}$ )" or "Timing Waveform of Write With Port-To-Port Delay ( $M/\bar{S} = V_{SS}$ )".
2. To ensure that the earlier of the two ports wins.
3. t<sub>BDD</sub> is a calculated parameter and is the greater of 0ns, t<sub>WDD</sub> – t<sub>WP</sub> (actual) or t<sub>DDD</sub> – t<sub>DW</sub> (actual).
4. To ensure that the write cycle is inhibited during contention.
5. To ensure that a write cycle is completed after contention.

### Timing Waveform of Read with $\overline{\text{BUSY}}^{(2,4,5)}$ ( $M/\overline{S} = V_{IH}$ )

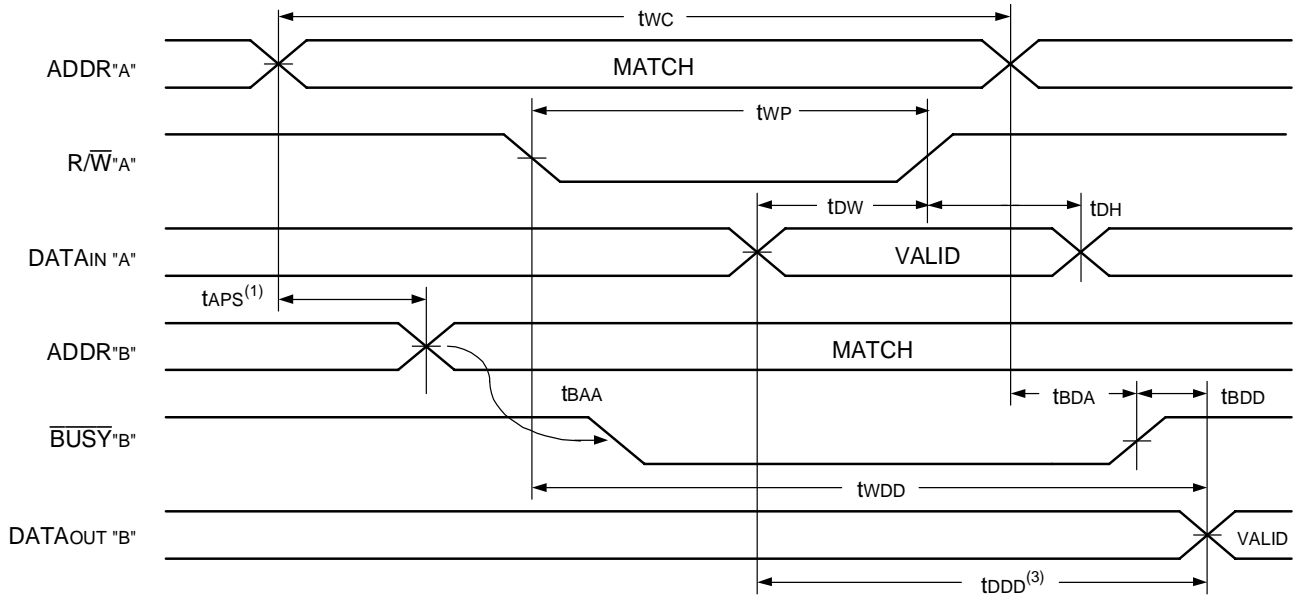

5684 drw 10

**NOTES:**

- To ensure that the earlier of the two ports wins.  $t_{APs}$  is ignored for  $M/\overline{S} = V_{IL}$  (slave).
- $\overline{CE}_L = \overline{CE}_R = V_{IL}$ .
- $\overline{OE} = V_{IL}$  for the reading port.
- If  $M/\overline{S} = V_{SS}$  (slave),  $\overline{\text{BUSY}}$  is an input. Then for this example  $\overline{\text{BUSY}}^A = V_{IH}$  and  $\overline{\text{BUSY}}^B$  input is shown above.
- All timing is the same for both left and right ports. Port "A" may be either the left or right Port. Port "B" is the port opposite from port "A".

### Timing Waveform of Slave Write ( $M/\overline{S} = V_{IL}$ )

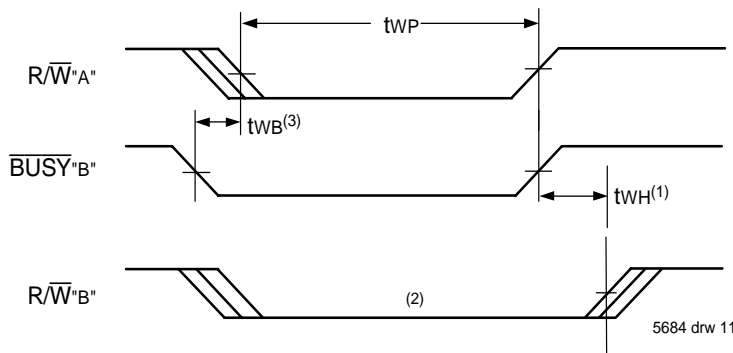

5684 drw 11

**NOTES:**

- $t_{WH}$  must be met for both  $\overline{\text{BUSY}}$  input (slave) and output (master).
- Busy is asserted on port "B" blocking  $R/\overline{W}^B$ , until  $\overline{\text{BUSY}}^B$  goes HIGH.
- $t_{WB}$  is only for the "slave" version.

### Waveform of $\overline{\text{BUSY}}$ Arbitration Controlled by $\overline{\text{CE}}$ Timing<sup>(1)</sup> ( $M/\overline{S} = V_{IH}$ )

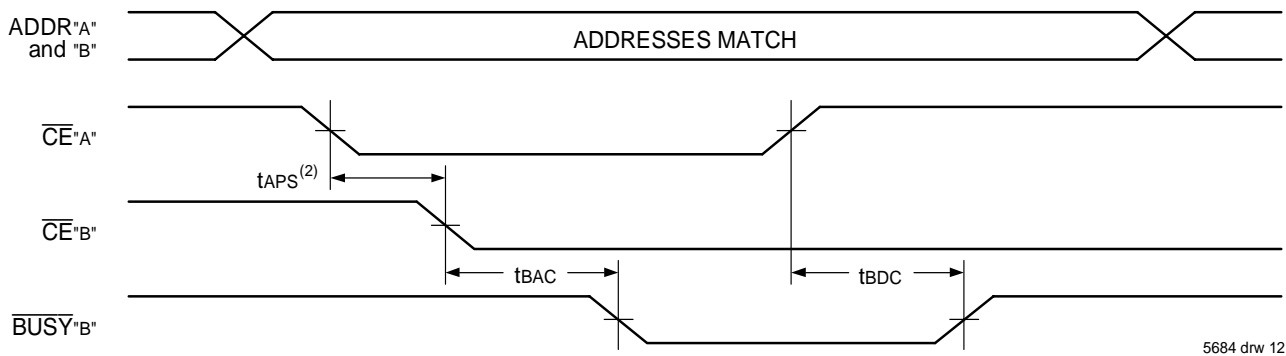

### Waveform of $\overline{\text{BUSY}}$ Arbitration Cycle Controlled by Address Match Timing<sup>(1)</sup> ( $M/\overline{S} = V_{IH}$ )

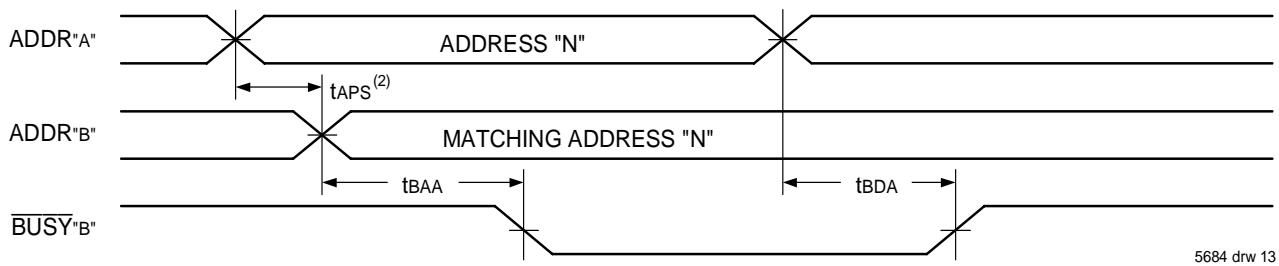

**NOTES:**

1. All timing is the same for left and right ports. Port "A" may be either the left or right port. Port "B" is the port opposite from "A".
2. If tAPS is not satisfied, the  $\overline{\text{BUSY}}$  signal will be asserted on one side or another but there is no guarantee on which side  $\overline{\text{BUSY}}$  will be asserted.

## AC Electrical Characteristics Over the Operating Temperature and Supply Voltage Range

Symbol	Parameter	70P257/247 Ind'l Only		Unit
		Min.	Max.	
<b>INTERRUPT TIMING</b>				
tAS	Address Set-up Time	0	—	ns
tWR	Write Recovery Time	0	—	ns
tINS	Interrupt Set Time	—	45	ns
tNR	Interrupt Reset Time	—	45	ns

5684 tbl 14

## Waveform of Interrupt Timing<sup>(1)</sup>

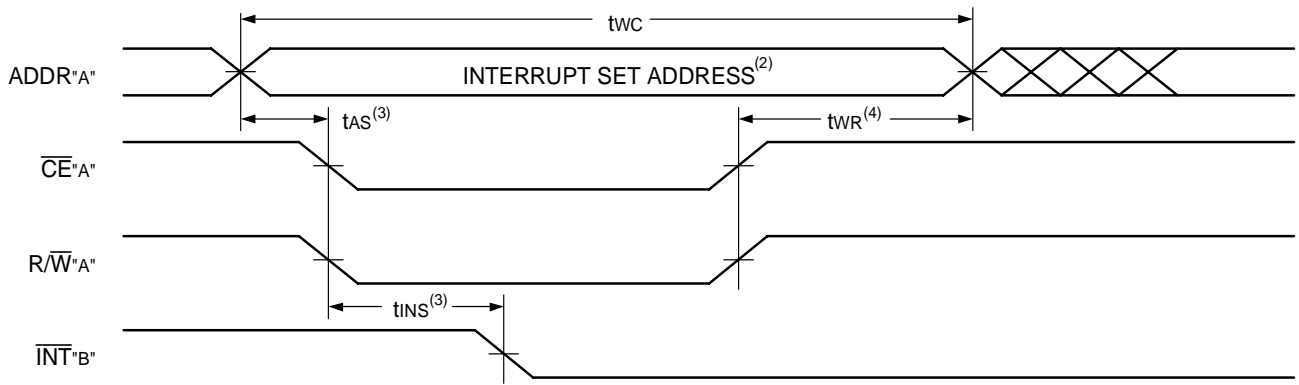

5684 drw 14

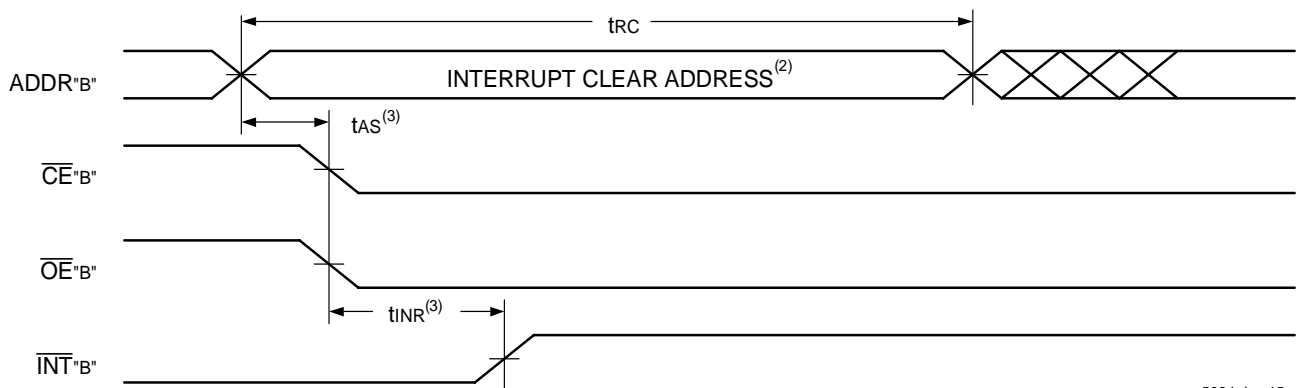

5684 drw 15

### NOTES:

1. All timing is the same for left and right ports. Port "A" may be either the left or right port. Port "B" is the port opposite from "A".
2. See Interrupt Truth Table III.
3. Timing depends on which enable signal ( $\overline{CE}$  or  $R/\overline{W}$ ) is asserted last.
4. Timing depends on which enable signal ( $\overline{CE}$  or  $R/\overline{W}$ ) is de-asserted first.



### Truth Table III — Interrupt Flag<sup>(1)</sup>

Left Port					Right Port					Function
R/W <sub>L</sub>	C <sub>EL</sub>	O <sub>EL</sub>	A <sub>12L-A<sub>0L</sub>(4)</sub>	I <sub>N<sub>T</sub>L</sub>	R/W <sub>R</sub>	C <sub>ER</sub>	O <sub>ER</sub>	A <sub>12R-A<sub>0R</sub>(4)</sub>	I <sub>N<sub>T</sub>R</sub>	
L	L	X	1FFF	X	X	X	X	X	L <sup>(2)</sup>	Set Right I <sub>N<sub>T</sub>R</sub> Flag
X	X	X	X	X	X	L	L	1FFF	H <sup>(3)</sup>	Reset Right I <sub>N<sub>T</sub>R</sub> Flag
X	X	X	X	L <sup>(3)</sup>	L	L	X	1FFE	X	Set Left I <sub>N<sub>T</sub>L</sub> Flag
X	L	L	1FFE	H <sup>(2)</sup>	X	X	X	X	X	Reset Left I <sub>N<sub>T</sub>L</sub> Flag

5684 tbl 15

**NOTES:**

1. Assumes  $\overline{\text{BUSY}}_L = \overline{\text{BUSY}}_R = V_{IH}$ .
2. If  $\overline{\text{BUSY}}_L = V_{IL}$ , then no change.
3. If  $\overline{\text{BUSY}}_R = V_{IL}$ , then no change.
4. A<sub>12x</sub> is a NC for IDT70P247, therefore Interrupt Addresses are FFF and FFE.

### Truth Table IV — Address $\overline{\text{BUSY}}$ Arbitration

Inputs			Outputs		Function
C <sub>EL</sub>	C <sub>ER</sub>	A <sub>0L-A<sub>12L</sub>(4) A<sub>0R-A<sub>12R</sub></sub></sub>	$\overline{\text{BUSY}}_L$ <sup>(1)</sup>	$\overline{\text{BUSY}}_R$ <sup>(1)</sup>	
X	X	NO MATCH	H	H	Normal
H	X	MATCH	H	H	Normal
X	H	MATCH	H	H	Normal
L	L	MATCH	(2)	(2)	Write Inhibit <sup>(3)</sup>

5684 tbl 16

**NOTES:**

1. Pins  $\overline{\text{BUSY}}_L$  and  $\overline{\text{BUSY}}_R$  are both outputs when the part is configured as a master. Both are inputs when configured as a slave.  $\overline{\text{BUSY}}$  outputs on the IDT70P257/247 are push pull, not open drain outputs. On slaves the  $\overline{\text{BUSY}}$  input internally inhibits writes.
2. L if the inputs to the opposite port were stable prior to the address and enable inputs of this port.  $V_{IH}$  if the inputs to the opposite port became stable after the address and enable inputs of this port. If  $t_{APS}$  is not met, either  $\overline{\text{BUSY}}_L$  or  $\overline{\text{BUSY}}_R = \text{LOW}$  will result.  $\overline{\text{BUSY}}_L$  and  $\overline{\text{BUSY}}_R$  outputs cannot be LOW simultaneously.
3. Writes to the left port are internally ignored when  $\overline{\text{BUSY}}_L$  outputs are driving LOW regardless of actual logic level on the pin. Writes to the right port are internally ignored when  $\overline{\text{BUSY}}_R$  outputs are driving LOW regardless of actual logic level on the pin.
4. A<sub>0L</sub> — A<sub>11L</sub> and A<sub>0R</sub> — A<sub>11R</sub> for IDT70P247.

### Truth Table V — Example of Semaphore Procurement Sequence<sup>(1,2,3)</sup>

Functions	D <sub>0</sub> - D <sub>15</sub> Left	D <sub>0</sub> - D <sub>15</sub> Right	Status
No Action	1	1	Semaphore free
Left Port Writes "0" to Semaphore	0	1	Left port has semaphore token
Right Port Writes "0" to Semaphore	0	1	No change. Right side has no write access to semaphore
Left Port Writes "1" to Semaphore	1	0	Right port obtains semaphore token
Left Port Writes "0" to Semaphore	1	0	No change. Left port has no write access to semaphore
Right Port Writes "1" to Semaphore	0	1	Left port obtains semaphore token
Left Port Writes "1" to Semaphore	1	1	Semaphore free
Right Port Writes "0" to Semaphore	1	0	Right port has semaphore token
Right Port Writes "1" to Semaphore	1	1	Semaphore free
Left Port Writes "0" to Semaphore	0	1	Left port has semaphore token
Left Port Writes "1" to Semaphore	1	1	Semaphore free

5684 tbl 17

**NOTES:**

1. This table denotes a sequence of events for only one of the eight semaphores on the IDT70P257/247.
2. There are eight semaphore flags written to via I/O<sub>0</sub> and read from all I/O's (I/O<sub>0</sub>-I/O<sub>15</sub>). These eight semaphores are addressed by A<sub>0</sub>-A<sub>2</sub>.
3.  $\overline{CE} = V_{IH}$ ,  $\overline{SEM} = V_{IL}$  to access the semaphores. Refer to the Semaphore Read/Write Control Truth Table.

### Truth Table VI — Input Read Register Operation<sup>(3)</sup>

SFEN	CE	R/W	OE	UB	LB	ADDR	I/O <sub>0</sub> -I/O <sub>1</sub>	I/O <sub>2</sub> -I/O <sub>15</sub>	Mode
H	L	H	L	L <sup>(1)</sup>	L <sup>(1)</sup>	x0000 - Max	VALID <sup>(1)</sup>	VALID <sup>(1)</sup>	Standard Memory Access
L	L	H	L	X	L	x0000	VALID <sup>(2)</sup>	X	IRR Read <sup>(3)</sup>

5684 tbl 18

**NOTES:**

1.  $\overline{UB}$  or  $\overline{LB} = V_{IL}$ . If  $\overline{LB} = V_{IL}$ , then I/O<sub>0</sub> - I/O<sub>7</sub> are VALID. If  $\overline{UB} = V_{IL}$ , then I/O<sub>8</sub> - I/O<sub>15</sub> are VALID.
2.  $\overline{LB}$  must be active ( $\overline{LB} = V_{IL}$ ) for these bits to be valid.
3. SFEN = V<sub>IL</sub> to activate IRR reads.

### Truth Table VII — Output Drive Register Operation<sup>(5)</sup>

SFEN	CE	R/W	OE	UB	LB	ADDR	I/O <sub>0</sub> -I/O <sub>4</sub>	I/O <sub>5</sub> -I/O <sub>15</sub>	Mode
H	L	H	X <sup>(1)</sup>	L <sup>(2)</sup>	L <sup>(2)</sup>	x0000 - Max	VALID <sup>(2)</sup>	VALID <sup>(2)</sup>	Standard Memory Access
L	L	L	X	X	L	x0001	VALID <sup>(3)</sup>	X	ODR Write <sup>(4,5)</sup>
L	L	H	L	X	L	x0001	VALID <sup>(3)</sup>	X	ODR Read <sup>(5)</sup>

5684 tbl 19

**NOTES:**

1. Output enable must be low (OE = V<sub>il</sub>) during reads for valid data to be output.
2.  $\overline{UB}$  or  $\overline{LB} = V_{IL}$ . If  $\overline{LB} = V_{IL}$ , then I/O<sub>0</sub> - I/O<sub>7</sub> are VALID. If  $\overline{UB} = V_{IL}$ , then I/O<sub>8</sub> - I/O<sub>15</sub> are VALID.
3.  $\overline{LB}$  must be active ( $\overline{LB} = V_{IL}$ ) for these bits to be valid.
4. During ODR writes data will also be written to the memory.
5. SFEN = V<sub>IL</sub> to activate ODR reads and writes.

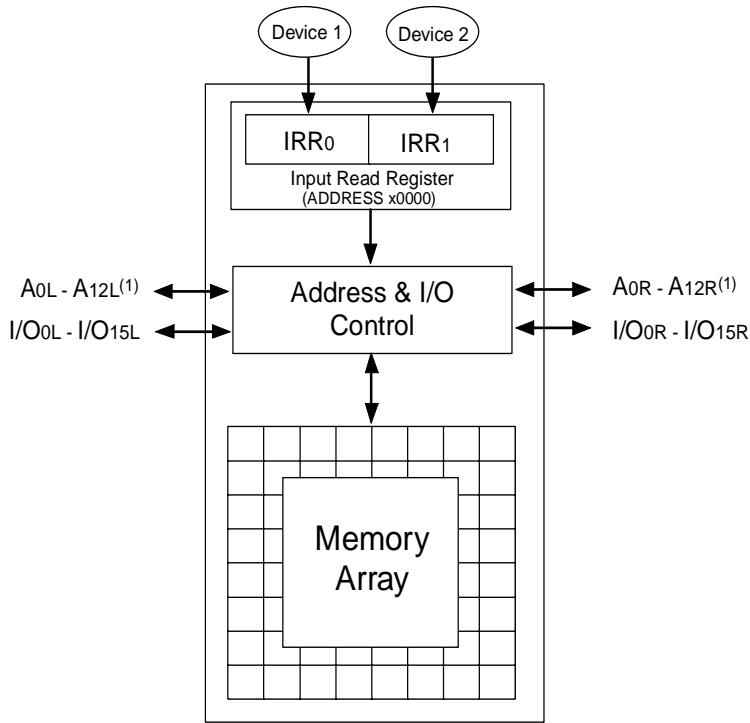

5684 drw 16

Figure 3. Input Read Register

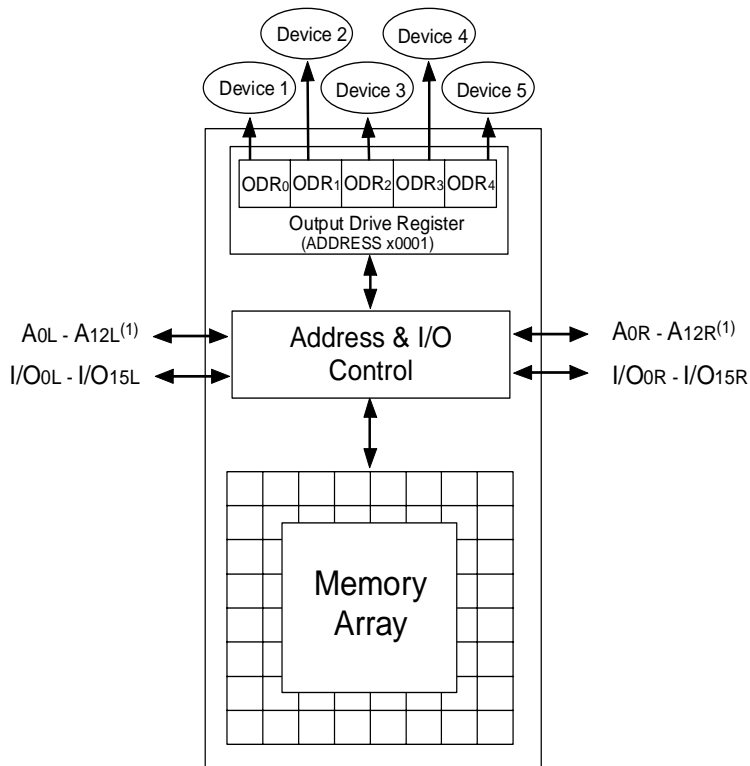

5684 drw 17

Figure 4. Output Drive Register

**NOTE:**

1. A12x is a NC for IDT70P247.

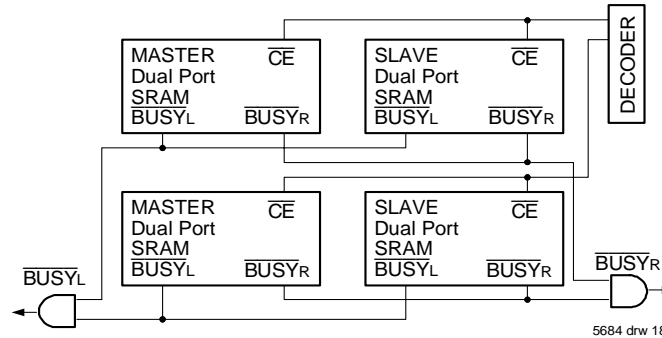

Figure 3. Busy and chip enable routing for both width and depth expansion with IDT70P257/247 SRAMs.

## Functional Description

The IDT70P257/247 provides two ports with separate control, address and I/O pins that permit independent access to any location in memory. The IDT70P257/247 has an automatic power down feature controlled by  $\overline{CE}$ . The  $\overline{CE}$  controls on-chip power down circuitry that permits the respective port to go into a standby mode when not selected ( $\overline{CE}$  HIGH). When a port is enabled, access to the entire memory array is permitted.

## Interrupts

If the user chooses the interrupt function, a memory location (mail box or message center) is assigned to each port. The left port interrupt flag ( $\overline{INTL}$ ) is asserted when the right port writes to memory location 1FFE (HEX) (FFE for IDT70P247), where a write is defined as the  $\overline{CE} = R/\overline{W} = V_{IL}$  per Truth Table III. The left port clears the interrupt by accessing address location 1FFE when  $\overline{CE}_R = \overline{OER} = V_{IL}$ ,  $R/\overline{W}$  is a "don't care". Likewise, the right port interrupt flag ( $\overline{INTR}$ ) is asserted when the left port writes to memory location 1FFF (HEX) (FFF for IDT70P247) and to clear the interrupt flag ( $\overline{INTR}$ ), the right port must read the memory location 1FFF. The message (16 bits) at 1FFE or 1FFF is user-defined, since it is an addressable SRAM location. If the interrupt function is not used, address locations 1FFE and 1FFF are not used as mail boxes, but as part of the random access memory. Refer to Truth Table III for the interrupt operation.

## Busy Logic

Busy Logic provides a hardware indication that both ports of the SRAM have accessed the same location at the same time. It also allows one of the two accesses to proceed and signals the other side that the SRAM is "busy". The  $\overline{BUSY}$  pin can then be used to stall the access until the operation on the other side is completed. If a write operation has been attempted from the side that receives a  $\overline{BUSY}$  indication, the write signal is gated internally to prevent the write from proceeding.

The use of  $\overline{BUSY}$  logic is not required or desirable for all applications. In some cases it may be useful to logically OR the  $\overline{BUSY}$  outputs together and use any  $\overline{BUSY}$  indication as an interrupt source to flag the event of an illegal or illogical operation. If the write inhibit function of  $\overline{BUSY}$  logic is not desirable, the  $\overline{BUSY}$  logic can be disabled by placing the part in slave mode with the  $M/\overline{S}$  pin. Once in slave mode the  $\overline{BUSY}$  pin operates solely as a write inhibit input pin. Normal operation can be programmed by tying the  $\overline{BUSY}$  pins HIGH. If desired, unintended write operations can be prevented to a port by tying the  $\overline{BUSY}$  pin for that port LOW.

The busy outputs on the IDT 70P257/247 SRAM in master mode, are push-pull type outputs and do not require pull up resistors to operate. If these SRAMs are being expanded in depth, then the  $\overline{BUSY}$  indication for the resulting array requires the use of an external AND gate.

## Width Expansion with $\overline{BUSY}$ Logic Master/Slave Arrays

When expanding an IDT70P257/247 SRAM array in width while using busy logic, one master part is used to decide which side of the SRAM array will receive a  $\overline{BUSY}$  indication, and to output that indication. Any number of slaves to be addressed in the same address range as the master, use the  $\overline{BUSY}$  signal as a write inhibit signal. Thus on the IDT70P257/247 SRAM the  $\overline{BUSY}$  pin is an output if the part is used as a master ( $M/\overline{S}$  pin =  $V_{DD}$ ), and the  $\overline{BUSY}$  pin is an input if the part used as a slave ( $M/\overline{S}$  pin =  $V_{SS}$ ) as shown in Figure 3.

If two or more master parts were used when expanding in width, a split decision could result with one master indicating  $\overline{BUSY}$  on one side of the array and another master indicating  $\overline{BUSY}$  on one other side of the array. This would inhibit the write operations from one port for part of a word and inhibit the write operations from the other port for the other part of the word.

The  $\overline{BUSY}$  arbitration, on a master, is based on the chip enable and address signals only. It ignores whether an access is a read or write. In a master/slave array, both address and chip enable must be valid long enough for a  $\overline{BUSY}$  flag to be output from the master before the actual write pulse can be initiated with either the  $R/\overline{W}$  signal or the byte enables. Failure to observe this timing can result in a glitched internal write inhibit signal and corrupted data in the slave.

## Input Read Register

The Input Read Register (IRR) of the IDT70P257/247 captures the status of two external binary input devices connected to the Input Read pins (e.g. DIP switches). The contents of the IRR are read as a standard memory access to address x0000 from either port and the data is output via the standard I/Os (Truth Table VI). During Input Register reads I/O0 - I/O1 are valid bits and I/O2 - I/O15 are "Don't Care". Writes to address x0000 are not allowed from either port. When  $\overline{SFEN} = V_{IL}$ , the IRR is active and address x0000 is not available for standard memory operations. When  $\overline{SFEN} = V_{IH}$ , the IRR is inactive and address x0000 can be used as part of the main memory. The IRR supports inputs up to 3.5V ( $V_{IL} \leq 0.4V$ ,  $V_{IH} \geq 1.4V$ ). Refer to Figure 3 and Truth Table VI for Input Read Register operation.

## Output Drive Register

The Output Drive Register (ODR) of the IDT70P257/247 determines the state of up to five external binary-state devices by providing a path to  $V_{SS}$  for the external circuit. The five external devices supported by the ODR can operate at different voltages ( $1.5V \leq V_{SUPPLY} \leq 3.5V$ ), but the combined current of the devices must not exceed 40 mA (8 mA  $I_{MAX}$  for each external device). The status of the ODR bits is set using standard write accesses from either port to address x0001 with a "1" corresponding to "on" and a "0" corresponding to "off". The status of the ODR bits can also be read (without changing the status of the bits) via a standard read to address x0001. When  $\overline{SFEN} = V_{IL}$ , the ODR is active and address x0001 is not available for standard memory operations. When  $\overline{SFEN} = V_{IH}$ , the ODR is inactive and address x0001 can be used as part of the main memory. During reads and writes to the ODR I/O0 - I/O4 are valid bits and I/O5 - I/O15 are "Don't Care". Refer to Figure 4 and Truth Table VII for Output Drive Register operation.

## Semaphores

The IDT70P257/247 is an extremely fast Dual-Port 8K/4K x 16 CMOS Static RAM with an additional 8 address locations dedicated to binary semaphore flags. These flags allow either processor on the left or right side of the Dual-Port SRAM to claim a privilege over the other processor for functions defined by the system designer's software. As an example, the semaphore can be used by one processor to inhibit the other from accessing a portion of the Dual-Port SRAM or any other shared resource.

The Dual-Port SRAM features a fast access time, and both ports are completely independent of each other. This means that the activity on the left port in no way slows the access time of the right port. Both ports are identical in function to standard CMOS Static RAM and can be accessed to, at the same time with the only possible conflict arising from the simultaneous writing of, or a simultaneous READ/WRITE of, a non-semaphore location. Semaphores are protected against such ambiguous situations and may be used by the system program to avoid any conflicts in the non-semaphore portion of the Dual-Port SRAM. These devices have an automatic power-down feature controlled by  $\overline{CE}$ , the Dual-Port SRAM enable, and  $\overline{SEM}$ , the semaphore enable. The  $\overline{CE}$  and  $\overline{SEM}$  pins control on-chip power down circuitry that permits the respective port to go into standby mode when not selected. This is the condition which is shown in Truth Table I where  $\overline{CE}$  and  $\overline{SEM}$  are LOW.

Systems which can best use the IDT70P257/247 contain multiple processors or controllers and are typically very high-speed systems which are software controlled or software intensive. These systems can benefit from a performance increase offered by the IDT70P257/247's hardware semaphores, which provide a lockout mechanism without requiring complex programming.

Software handshaking between processors offers the maximum in system flexibility by permitting shared resources to be allocated in varying configurations. The IDT70P257/247 does not use its semaphore flags to control any resources through hardware, thus allowing the system designer total flexibility in system architecture.

An advantage of using semaphores rather than the more common methods of hardware arbitration is that wait states are never incurred in either processor. This can prove to be a major advantage in very high-speed systems.

## How the Semaphore Flags Work

The semaphore logic is a set of eight latches which are independent of the Dual-Port SRAM. These latches can be used to pass a flag, or token, from one port to the other to indicate that a shared resource is in use. The semaphores provide a hardware assist for a use assignment method called "Token Passing Allocation." In this method, the state of a semaphore latch is used as a token indicating that shared resource is in use. If the left processor wants to use this resource, it requests the token by setting the latch. This processor then verifies its success in setting the latch by reading it. If it was successful, it proceeds to assume control over the shared resource. If it was not successful in setting the latch, it determines that the right side processor has set the latch first, has the token and is using the shared resource. The left processor can then either repeatedly request that semaphore's status or remove its request for that semaphore to perform another task and occasionally attempt again to gain control of the token via the set and test sequence. Once the right side has relinquished the token, the left side should succeed in gaining control.

The semaphore flags are active HIGH. A token is requested by writing a zero into a semaphore latch and is released when the same side writes a one to that latch.

The eight semaphore flags reside within the IDT70P257/247 in a separate memory space from the Dual-Port SRAM. This address space is accessed by placing a LOW input on the  $\overline{SEM}$  pin (which acts as a chip select for the semaphore flags) and using the other control pins (Address,  $\overline{OE}$ , and R/W) as they would be used in accessing a standard Static RAM. Each of the flags has a unique address which can be accessed by either side through address pins A0 - A2. When accessing the semaphores, none of the other address pins has any effect.

When writing to a semaphore, only data pin D0 is used. If a LOW level is written into an unused semaphore location, that flag will be set to a zero on that side and a one on the other side (see Truth Table V). That semaphore can now only be modified by the side showing the zero. When a one is written into the same location from the same side, the flag will be set to a one for both sides (unless a semaphore request from the other side is pending) and then can be written to by both sides. The fact that the side which is able to write a zero into a semaphore subsequently locks out writes from the other side is what makes semaphore flags useful in interprocessor communications. (A thorough discussion on the use of this feature follows shortly.) A zero written into the same location from the other side will be stored in the semaphore request latch for that side until the semaphore is freed by the first side.

When a semaphore flag is read, its value is spread into all data bits so that a flag that is a one reads as a one in all data bits and a flag containing a zero reads as all zeros. The read value is latched into one side's output register when that side's semaphore select ( $\overline{SEM}$ ) and output enable ( $\overline{OE}$ ) signals go active. This serves to disallow the semaphore from changing state in the middle of a read cycle due to a write cycle from the other side. Because of this latch, a repeated read of a semaphore in a test loop must cause either signal ( $\overline{SEM}$  or  $\overline{OE}$ ) to go inactive or the output will never change.

A sequence WRITE/READ must be used by the semaphore in order to guarantee that no system level contention will occur. A processor requests access to shared resources by attempting to write a zero into a semaphore location. If the semaphore is already in use, the semaphore request latch will contain a zero, yet the semaphore flag will appear as one, a fact which the processor will verify by the

subsequent read (see Truth Table V). As an example, assume a processor writes a zero to the left port at a free semaphore location. On a subsequent read, the processor will verify that it has written successfully to that location and will assume control over the resource in question. Meanwhile, if a processor on the right side attempts to write a zero to the same semaphore flag it will fail, as will be verified by the fact that a one will be read from that semaphore on the right side during subsequent read. Had a sequence of READ/WRITE been used instead, system contention problems could have occurred during the gap between the read and write cycles.

It is important to note that a failed semaphore request must be followed by either repeated reads or by writing a one into the same location. The reason for this is easily understood by looking at the simple logic diagram of the semaphore flag in Figure 4. Two semaphore request latches feed into a semaphore flag. Whichever latch is first to present a zero to the semaphore flag will force its side of the semaphore flag LOW and the other side HIGH. This condition will continue until a one is written to the same semaphore request latch. Should the other side's semaphore request latch have been written to a zero in the meantime, the semaphore flag will flip over to the other side as soon as a one is written into the first side's request latch. The second side's flag will now stay LOW until its semaphore request latch is written to a one. From this it is easy to understand that, if a semaphore is requested and the processor which requested it no longer needs the resource, the entire system can hang up until a one is written into that semaphore request latch.

The critical case of semaphore timing is when both sides request a single token by attempting to write a zero into it at the same time. The semaphore logic is specially designed to resolve this problem. If simultaneous requests are made, the logic guarantees that only one side receives the token. If one side is earlier than the other in making the request, the first side to make the request will receive the token. If both requests arrive at the same time, the assignment will be arbitrarily made to one port or the other.

One caution that should be noted when using semaphores is that semaphores alone do not guarantee that access to a resource is secure. As with any powerful programming technique, if semaphores are misused or misinterpreted, a software error can easily happen.

Initialization of the semaphores is not automatic and must be handled via the initialization program at power-up. Since any semaphore request flag which contains a zero must be reset to a one, all semaphores on both sides should have a one written into them at initialization from both sides to assure that they will be free when needed.

## Using Semaphores—Some Examples

Perhaps the simplest application of semaphores is their application as resource markers for the IDT70P257/247's Dual-Port SRAM. Say the 8K/4K x 16 SRAM was to be divided into two 4K/2K x 16 blocks which were to be dedicated at any one time to servicing either the left or right port. Semaphore 0 could be used to indicate the side which would control the lower section of memory, and Semaphore 1 could be defined as the indicator for the upper section of memory.

To take a resource, in this example the lower 4K/2K of Dual-Port SRAM, the processor on the left port could write and then read a zero in to Semaphore 0. If this task were successfully completed (a zero was read back rather than a one), the left processor would

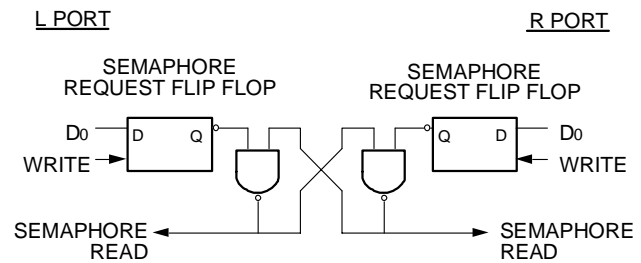

Figure 4. IDT70P257/247 Semaphore Logic

5684 drw 19

assume control of the lower 4K/2K. Meanwhile the right processor was attempting to gain control of the resource after the left processor, it would read back a one in response to the zero it had attempted to write into Semaphore 0. At this point, the software could choose to try and gain control of the second 4K/2K section by writing, then reading a zero into Semaphore 1. If it succeeded in gaining control, it would lock out the left side.

Once the left side was finished with its task, it would write a one to Semaphore 0 and may then try to gain access to Semaphore 1. If Semaphore 1 was still occupied by the right side, the left side could undo its semaphore request and perform other tasks until it was able to write, then read a zero into Semaphore 1. If the right processor performs a similar task with Semaphore 0, this protocol would allow the two processors to swap 4K/2K blocks of Dual-Port SRAM with each other.

The blocks do not have to be any particular size and can even be variable, depending upon the complexity of the software using the semaphore flags. All eight semaphores could be used to divide the Dual-Port SRAM or other shared resources into eight parts. Semaphores can even be assigned different meanings on different sides rather than being given a common meaning as was shown in the example above.

Semaphores are a useful form of arbitration in systems like disk interfaces where the CPU must be locked out of a section of memory during a transfer and the I/O device cannot tolerate any wait states. With the use of semaphores, once the two devices has determined which memory area was "off-limits" to the CPU, both the CPU and the I/O devices could access their assigned portions of memory continuously without any wait states.

Semaphores are also useful in applications where no memory "WAIT" state is available on one or both sides. Once a semaphore handshake has been performed, both processors can access their assigned SRAM segments at full speed.

Another application is in the area of complex data structures. In this case, block arbitration is very important. For this application one processor may be responsible for building and updating a data structure. The other processor then reads and interprets that data structure. If the interpreting processor reads an incomplete data structure, a major error condition may exist. Therefore, some sort of arbitration must be used between the two different processors. The building processor arbitrates for the block, locks it and then is able to go in and update the data structure. When the update is completed, the data structure block is released. This allows the interpreting processor to come back and read the complete data structure, thereby guaranteeing a consistent data structure.

## Ordering Information

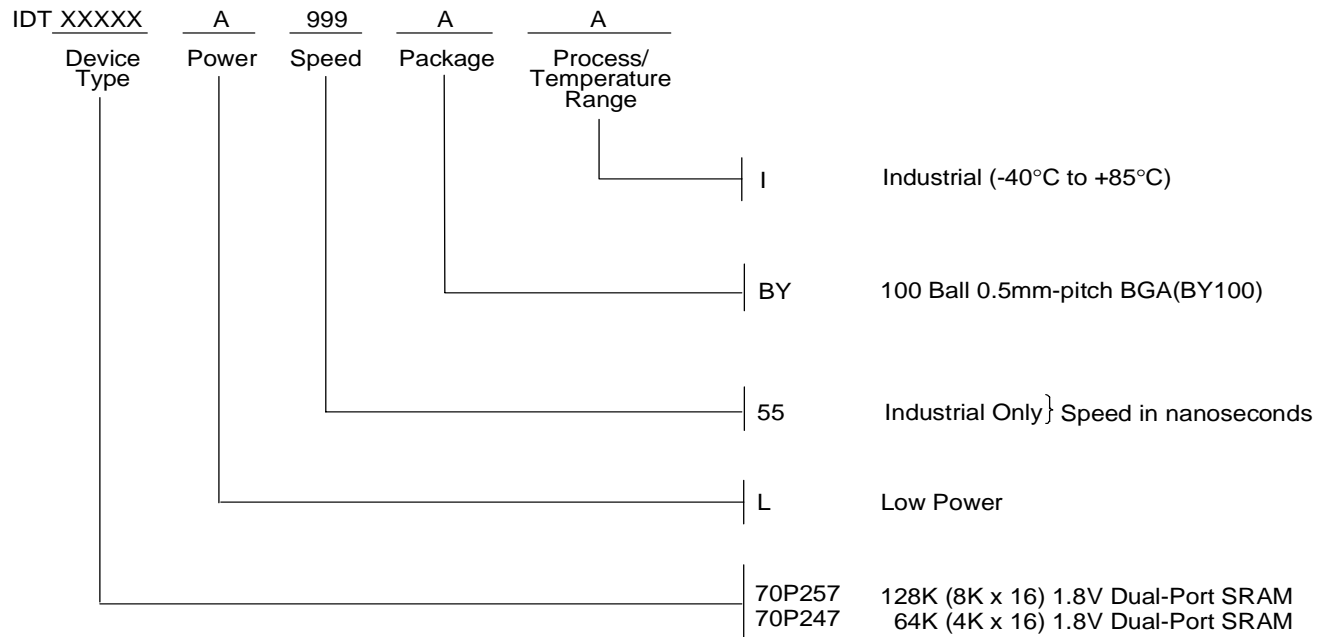

5684 drw 20

## Preliminary Datasheet: Definition

"PRELIMINARY" datasheets contain descriptions for products that are in early release.

## Datasheet Document History

02/04/04: Initial Datasheet



**CORPORATE HEADQUARTERS**  
 2975 Stender Way  
 Santa Clara, CA 95054

**for SALES:**  
 800-345-7015 or 408-727-6116  
 fax: 408-492-8674  
 www.idt.com

**for Tech Support:**  
 831-754-4613  
 DualPortHelp@idt.com

The IDT logo is a registered trademark of Integrated Device Technology, Inc.