

Melody Generator with Accompaniment

BT8048

FEATURES

- Two Sound Sources with Envelope (CR Envelope)
- Melody is inserted up to two.
- According to customer's request, the inserted melody is flexible.
- 3.0V to 5.0V Operating Voltage
- DC or AC Triggered Performance Start Mode (Mask Selected)
- Can Drive an 8 Ohm Dynamic Loudspeaker if Provided Externally with a Transistor
- Bare chip or 8-pin DIP (Plastic) Package available

DESCRIPTION

The BT8048 is a CMOS LSI chip, which plays a prearranged melodies.

ABSOLUTE MAXIMUM RATINGS ($T_a = 25^\circ\text{C}$)

Characteristic	Symbol	Value	Unit
Power Supply Voltage	V_{DD}	- 0.3 to + 7.0	V
Input Terminal Voltage	V_{I0}	- 0.2 to $V_{DD} + 0.2$	V
Operating Temperature	T_a	-40 to + 85 ($V_{SS} = 1.5\text{V}$)	$^\circ\text{C}$
Storage Temperature	T_{stg}	- 65 to + 150	$^\circ\text{C}$
Soldering Temperature and Time	T_{sol}	260 $^\circ\text{C}$, 10s (at lead)	

ORDERING INFORMATION
 BT8048N Plastic
 BT8048D SOIC
 $T_A = -40^\circ$ to 85° C for all packages

ELECTRICAL CHARACTERISTICS ($V_{DD} = 5\text{V}$, $T_a = 25^\circ\text{C}$; unless otherwise specified)

Characteristic	Symbol	Test Condition	Min	Typ	Max	Unit
Operating Voltage	V_{DD}		3.0	5.0	5.5	V
Input Voltage	"1"	V_{IH}	$V_{DD} - 0.3$	-	V_{DD}	V
	"0"	V_{IL}	V_{SS}	-	$V_{SS} + 0.3$	
MT Power Supply Time			150			ms
Response Time					600	ms

MO OUTPUT PIN EQUIVALENT CIRCUIT

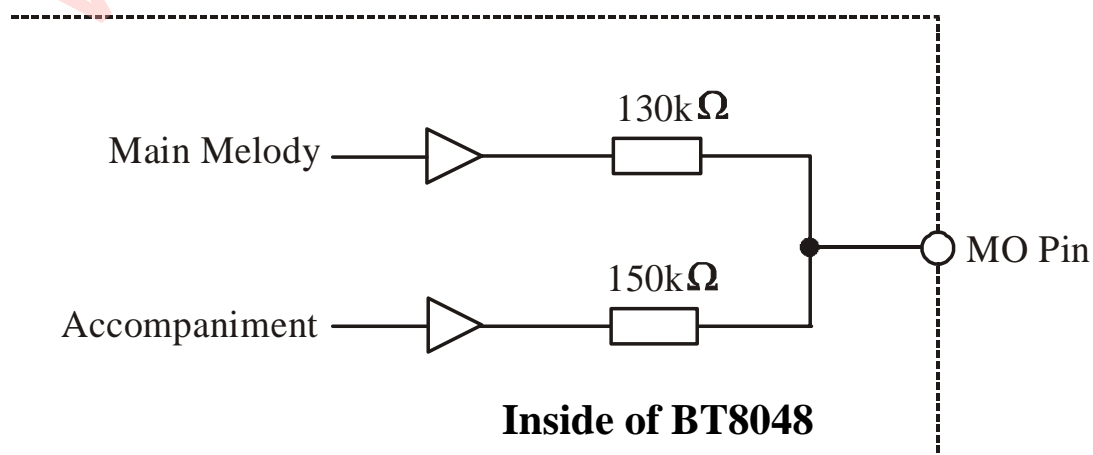

BLOCK DIAGRAM

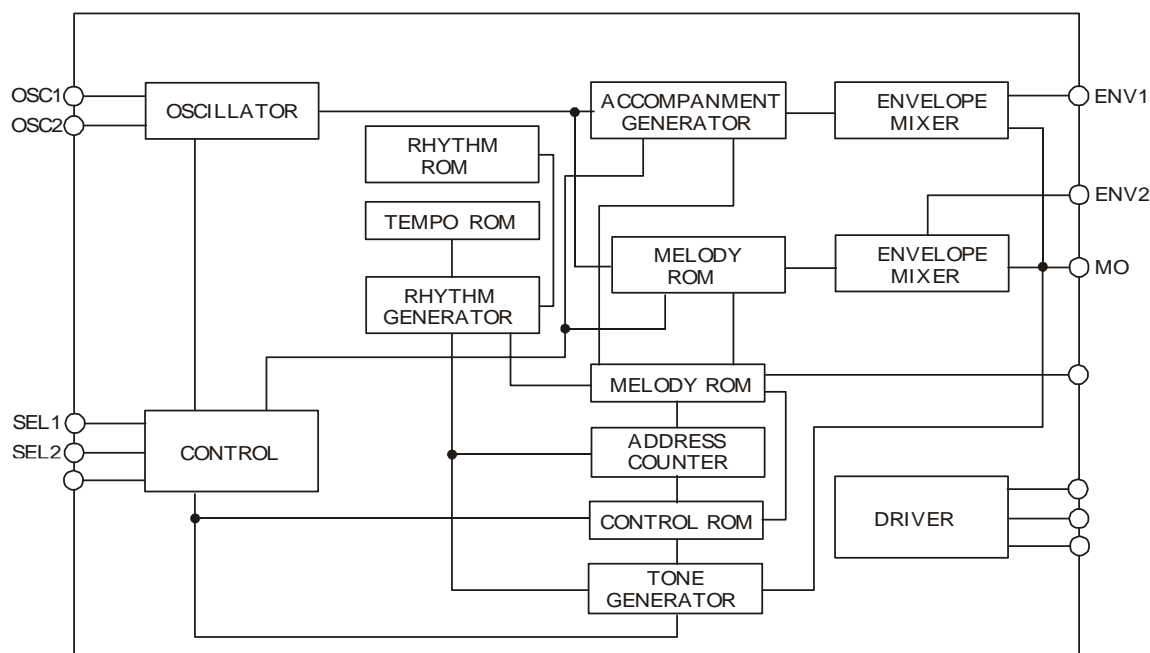

PIN DESCRIPTION

Pin. No.	Pin Name	Pull-Down Resistor	Functions
1	OSC1	-	A resistor is connected between both terminals to form an oscillator, or external reference signals are applied to OSC1.
2	OSC2	-	
3	SEL1	Provided	For binary selection: this Terminal in Conjunction with SEL2, selects a Melody. For direct selection: Selects Melody 2 and Controls Start and Stop of its Performance.
4	V _{SS}	-	Power Supply Terminal (0V).
5	ENV1	-	Connects Resistor and Capacitor to add Envelope to Main Melody.
6	ENV2	-	Connects Resistor and Capacitor to add Envelope to Accompaniment.
7	MO	-	Output Terminal or Acoustic Signals that have not been Amplified.
8	V _{DD}	-	3.0V to 5.0V Operating Voltage

APPLICATION CIRCUIT (basic external connection)

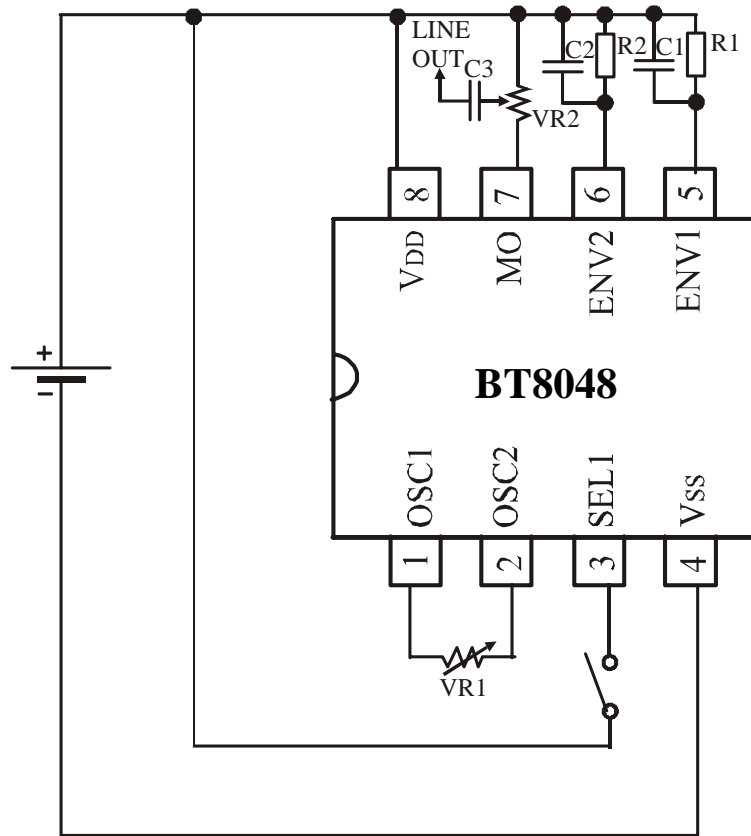

- CR Oscillation, DC Input

RECOMMENDED CONDITIONS FOR EXTERNAL DEVICES

Symbol	Ratings	Unit	Symbol	Ratings	Unit
VR1	1 - 2	MΩ	C1	4.7	μF
VR2	50	kΩ	C2	4.7	μF
R1	100	kΩ	C3	0.1	μF
R2	100	kΩ	-	-	-

MELODY SELECT TABLE

Melody	Switch	SEL1	SEL2
	Gong		OFF
Bong		ON	OFF
Up		OFF	ON
Down		ON	ON

**N SUFFIX PLASTIC DIP
(MS - 001BA)**

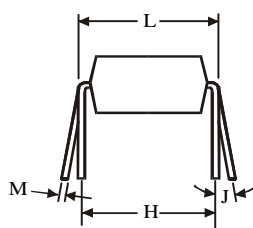
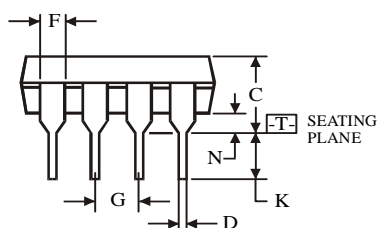
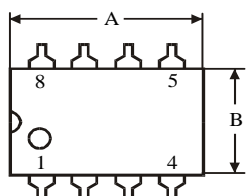
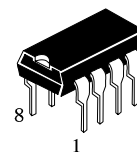

$\oplus 0.25 (0.010) \text{ (M) T}$

Symbol	Dimension, mm	
	MIN	MAX
A	8.51	10.16
B	6.1	7.11
C		5.33
D	0.36	0.56
F	1.14	1.78
G	2.54	
H	7.62	
J	0°	10°
K	2.92	3.81
L	7.62	8.26
M	0.2	0.36
N	0.38	

NOTES:

- Dimensions "A", "B" do not include mold flash or protrusions.
Maximum mold flash or protrusions 0.25 mm (0.010) per side.

**D SUFFIX SOIC
(MS - 012AA)**

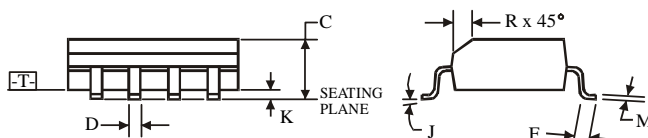
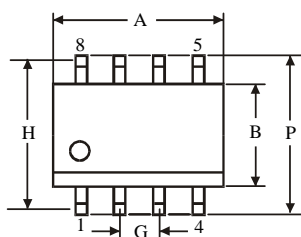
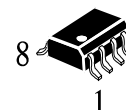

$\oplus 0.25 (0.010) \text{ (M) T C (M)}$

Symbol	Dimension, mm	
	MIN	MAX
A	4.8	5
B	3.8	4
C	1.35	1.75
D	0.33	0.51
F	0.4	1.27
G	1.27	
H	5.72	
J	0°	8°
K	0.1	0.25
M	0.19	0.25
P	5.8	6.2
R	0.25	0.5

NOTES:

- Dimensions A and B do not include mold flash or protrusion.
- Maximum mold flash or protrusion 0.15 mm (0.006) per side for A; for B - 0.25 mm (0.010) per side.