

FEMTOCLOCKS™ CRYSTAL-TO-3.3V, 2.5V LVPECL 75MHZ FREQUENCY SYNTHESIZER W/SSC

ICS843301I-108

GENERAL DESCRIPTION



The ICS843301I-108 is a 75MHz Frequency Generator and a member of the HiPerClocks™ family of high performance devices from IDT. The ICS843301I-108 uses a 20MHz crystal to synthesize 75MHz output. The device supports 0.5% downspread spread spectrum clocking. The ICS843301I-108 has excellent <1ps phase jitter performance, over an integration range of 900kHz - 7.5MHz. The device is packaged in a small 8-pin TSSOP, making it ideal for use in systems with limited board space.

FEATURES

- One differential 3.3V or 2.5V LVPECL output
- Crystal oscillator interface designed for 20MHz, 18pF parallel resonant crystal
- Output frequency: 75MHz
- Supports SSC, 0.5% downspread
- RMS phase jitter @ 75MHz, using a 20MHz crystal (900kHz - 7.5MHz): 0.73ps (typical)
- Full 3.3V or 2.5V operating supply
- -40°C to 85°C ambient operating temperature
- Available in both standard (RoHS 5) and lead-free (RoHS 6) packages

SSC FUNCTION TABLE

Input SSC	Mode
0 (default)	SSC Off
1	0.5% Downspread

BLOCK DIAGRAM

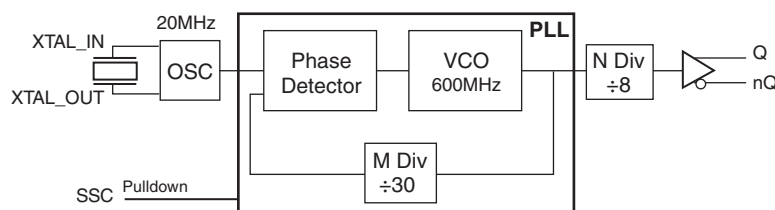

PIN ASSIGNMENT

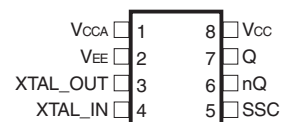

ICS843301I-108

8-Lead TSSOP

4.40mm x 3.0mm x 0.925mm package body

G Package

Top View

The Preliminary Information presented herein represents a product in pre-production. The noted characteristics are based on initial product characterization and/or qualification. Integrated Device Technology, Incorporated (IDT) reserves the right to change any circuitry or specifications without notice.

TABLE 1. PIN DESCRIPTIONS

Number	Name	Type		Description
1	V _{CCA}	Power		Analog supply pin.
2	V _{EE}	Power		Negative supply pin.
3, 4	XTAL_OUT, XTAL_IN	Input		Crystal oscillator interface. XTAL_IN is the input, XTAL_OUT is the output.
5	SSC	Input	Pulldown	SSC control pin. LVCMOS/LVTTL interface levels.
6, 7	nQ, Q	Output		Differential clock outputs. LVPECL interface levels.
8	V _{CC}	Power		Core and output supply pin.

NOTE: *Pulldown* refers to internal input resistors. See Table 2, Pin Characteristics, for typical values.

TABLE 2. PIN CHARACTERISTICS

Symbol	Parameter	Test Conditions	Minimum	Typical	Maximum	Units
C _{IN}	Input Pin Capacitance			4		pF
R _{PULLDOWN}	Input Pulldown Resistor			51		kΩ

ABSOLUTE MAXIMUM RATINGS

Supply Voltage, V_{CC}	4.6V
Inputs, V_I	-0.5V to $V_{CC} + 0.5V$
Outputs, I_O	
Continuous Current	50mA
Surge Current	100mA
Package Thermal Impedance, θ_{JA}	101.7°C/W (0 mps)
Storage Temperature, T_{STG}	-65°C to 150°C

NOTE: Stresses beyond those listed under Absolute Maximum Ratings may cause permanent damage to the device. These ratings are stress specifications only. Functional operation of product at these conditions or any conditions beyond those listed in the *DC Characteristics* or *AC Characteristics* is not implied. Exposure to absolute maximum rating conditions for extended periods may affect product reliability.

TABLE 3A. POWER SUPPLY DC CHARACTERISTICS, $V_{CC} = 3.3V \pm 5\%$, $T_A = -40^\circ C$ TO $85^\circ C$

Symbol	Parameter	Test Conditions	Minimum	Typical	Maximum	Units
V_{CC}	Core Supply Voltage		3.135	3.3	3.465	V
V_{CCA}	Analog Supply Voltage		$V_{CC} - 0.10$	3.3	V_{CC}	V
I_{CCA}	Analog Supply Current			10		mA
I_{EE}	Power Supply Current			106		mA

TABLE 3B. POWER SUPPLY DC CHARACTERISTICS, $V_{CC} = 2.5V \pm 5\%$, $T_A = -40^\circ C$ TO $85^\circ C$

Symbol	Parameter	Test Conditions	Minimum	Typical	Maximum	Units
V_{CC}	Core Supply Voltage		2.375	2.5	2.625	V
V_{CCA}	Analog Supply Voltage		$V_{CC} - 0.09$	2.5	V_{CC}	V
I_{CCA}	Analog Supply Current			9		mA
I_{EE}	Power Supply Current			100		mA

www.DataSheet4U.com

TABLE 3C. LVCMOS / LVTTTL DC CHARACTERISTICS, $V_{CC} = 3.3V \pm 5\%$ OR $2.5V \pm 5\%$, $T_A = -40^\circ C$ TO $85^\circ C$

Symbol	Parameter	Test Conditions	Minimum	Typical	Maximum	Units
V_{IH}	Input High Voltage	$V_{CC} = 3.3V$	2		$V_{CC} + 0.3$	V
		$V_{CC} = 2.5V$	1.7		$V_{CC} + 0.3$	V
V_{IL}	Input Low Voltage	$V_{CC} = 3.3V$	-0.3		0.8	V
		$V_{CC} = 2.5V$	-0.3		0.7	V
I_{IH}	Input High Current	$V_{CC} = V_{IN} = 3.465V$ or $2.625V$			150	μA
I_{IL}	Input Low Current	$V_{CC} = 3.465V$ or $2.625V$, $V_{IN} = 0V$	-5			μA

TABLE 3D. LVPECL DC CHARACTERISTICS, $V_{CC} = 3.3V \pm 5\%$ OR $2.5V \pm 5\%$, $T_A = -40^\circ C$ TO $85^\circ C$

Symbol	Parameter	Test Conditions	Minimum	Typical	Maximum	Units
V_{OH}	Output High Voltage; NOTE 1		$V_{CC} - 1.4$		$V_{CC} - 0.9$	V
V_{OL}	Output Low Voltage; NOTE 1		$V_{CC} - 2.0$		$V_{CC} - 1.7$	V
V_{SWING}	Peak-to-Peak Output Voltage Swing		0.6		1.0	V

NOTE 1: Outputs terminated with 50 Ω to $V_{CC} - 2V$.

TABLE 4. CRYSTAL CHARACTERISTICS

Parameter	Test Conditions	Minimum	Typical	Maximum	Units
Mode of Oscillation		Fundamental			
Frequency			20		MHz
Equivalent Series Resistance (ESR)				90	Ω
Shunt Capacitance				7	pF
Drive Level				300	μ W

TABLE 5A. AC CHARACTERISTICS, $V_{CC} = 3.3V \pm 5\%$, $T_A = -40^\circ\text{C}$ TO 85°C

Symbol	Parameter	Test Conditions	Minimum	Typical	Maximum	Units
f_{OUT}	Output Frequency			75		MHz
$f_{jit}(\emptyset)$	RMS Phase Jitter, (Random); NOTE 1, 2	75MHz (Integration Range: 900kHz - 7.5MHz)		0.73		ps
F_M	SSC Modulation Frequency; NOTE 3	$F_{OUT} = 75\text{MHz}$	29		33.33	kHz
F_{MF}	SSC Modulation Factor; NOTE 3	$F_{OUT} = 75\text{MHz}$		0.5		%
SSC_{red}	Spectral Reduction; NOTE 3	$F_{OUT} = 75\text{MHz}$		8		dB
t_R / t_F	Output Rise/Fall Time	20% to 80%		475		ps
odc	Output Duty Cycle			50		%

NOTE 1: Please refer to the Phase Noise Plot.

NOTE 2: Spread Spectrum clocking disabled.

NOTE 3: Spread Spectrum clocking enabled.

TABLE 5B. AC CHARACTERISTICS, $V_{CC} = 2.5V \pm 5\%$, $T_A = -40^\circ\text{C}$ TO 85°C

Symbol	Parameter	Test Conditions	Minimum	Typical	Maximum	Units
f_{OUT}	Output Frequency			75		MHz
$f_{jit}(\emptyset)$	RMS Phase Jitter, (Random); NOTE 1, 2	75MHz (Integration Range: 900kHz - 7.5MHz)		0.72		ps
F_M	SSC Modulation Frequency; NOTE 3	$F_{OUT} = 75\text{MHz}$	29		33.33	kHz
F_{MF}	SSC Modulation Factor; NOTE 3	$F_{OUT} = 75\text{MHz}$		0.4		%
SSC_{red}	Spectral Reduction; NOTE 3	$F_{OUT} = 75\text{MHz}$		7.5		dB
t_R / t_F	Output Rise/Fall Time	20% to 80%		450		ps
odc	Output Duty Cycle			50		%

NOTE 1: Please refer to the Phase Noise Plot.

NOTE 2: Spread Spectrum clocking disabled.

NOTE 3: Spread Spectrum clocking enabled.

PARAMETER MEASUREMENT INFORMATION

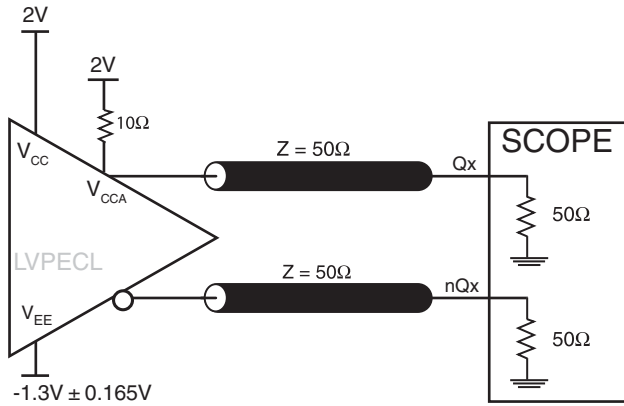

3.3V OUTPUT LOAD AC TEST CIRCUIT

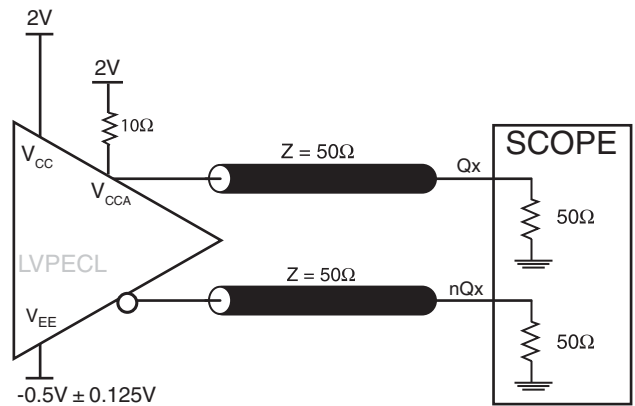

2.5V OUTPUT LOAD AC TEST CIRCUIT

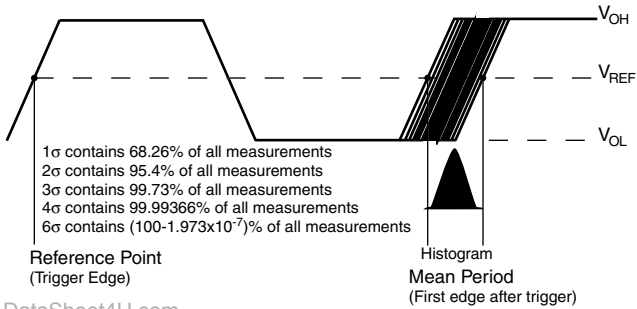

www.DataSheet4U.com

PERIOD JITTER

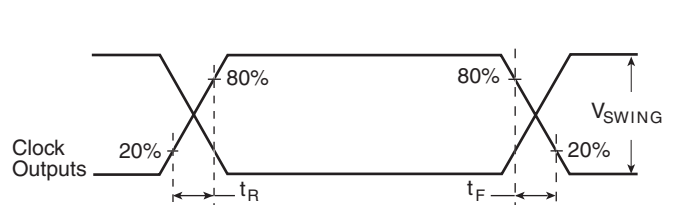

OUTPUT RISE/FALL TIME

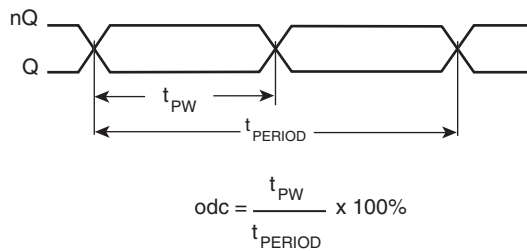

OUTPUT DUTY CYCLE/PULSE WIDTH/PERIOD

APPLICATION INFORMATION

POWER SUPPLY FILTERING TECHNIQUES

As in any high speed analog circuitry, the power supply pins are vulnerable to random noise. The ICS843301I-108 provides separate power supplies to isolate any high switching noise from the outputs to the internal PLL. V_{CC} and V_{CCA} should be individually connected to the power supply plane through vias, and bypass capacitors should be used for each pin. To achieve optimum jitter performance, power supply isolation is required. *Figure 1* illustrates how a 10Ω resistor along with a $10\mu\text{F}$ and a $0.01\mu\text{F}$ bypass capacitor should be connected to each V_{CCA} pin.

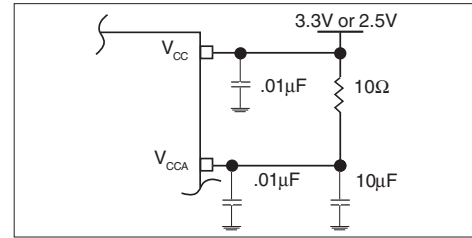

FIGURE 1. POWER SUPPLY FILTERING

CRYSTAL INPUT INTERFACE

The ICS843301I-108 has been characterized with 18pF parallel resonant crystals. The capacitor values, C1 and C2, shown in *Figure 2* below were determined using a 20MHz, 18pF parallel

resonant crystal and were chosen to minimize the ppm error. The optimum C1 and C2 values can be slightly adjusted for different board layouts.

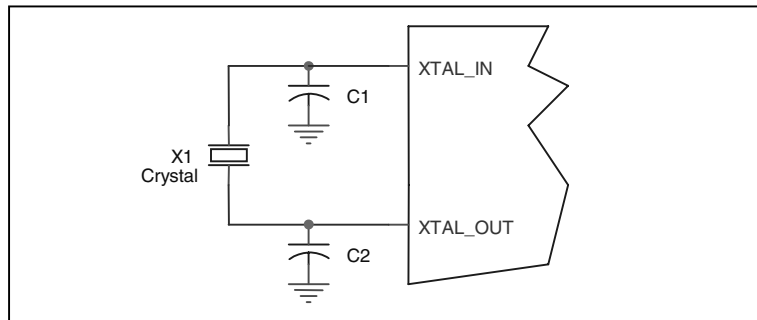

FIGURE 2. CRYSTAL INPUT INTERFACE

LVC MOS TO XTAL INTERFACE

The XTAL_IN input can accept a single-ended LVC MOS signal through an AC coupling capacitor. A general interface diagram is shown in *Figure 3*. The XTAL_OUT pin can be left floating. The input edge rate can be as slow as 10ns. For LVC MOS inputs, it is recommended that the amplitude be reduced from full swing to half swing in order to prevent signal interference with the power rail and to reduce noise. This configuration requires that the output

impedance of the driver (R_o) plus the series resistance (R_s) equals the transmission line impedance. In addition, matched termination at the crystal input will attenuate the signal in half. This can be done in one of two ways. First, R_1 and R_2 in parallel should equal the transmission line impedance. For most 50Ω applications, R_1 and R_2 can be 100Ω . This can also be accomplished by removing R_1 and making R_2 50Ω .

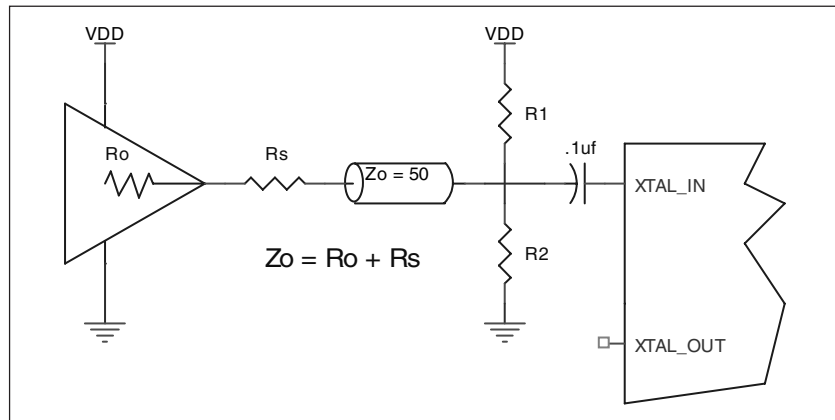

FIGURE 3. GENERAL DIAGRAM FOR LVC MOS DRIVER TO XTAL INPUT INTERFACE

SPREAD SPECTRUM

Spread-spectrum clocking is a frequency modulation technique for EMI reduction. When spread-spectrum is enabled, a 32kHz triangle waveform is used with 0.5% down-spread (+0.0% / TBD%) from the nominal 75MHz clock frequency. An example of a triangle frequency modulation profile is shown in *Figure 4A* below.

The ICS843301I-108 triangle modulation frequency deviation will not exceed TBD% down-spread from the nominal clock fre-

quency (+0.0% / TBD%). An example of the amount of down spread relative to the nominal clock frequency can be seen in the frequency domain, as shown in *Figure 4B*. The ratio of this difference to the fundamental frequency is typically 0.5%, and will not exceed TBD%. The resulting spectral reduction will be greater than 7dB, as shown in *Figure 4B*. It is important to note the ICS843301I-108 7dB minimum spectral reduction is the component-specific EMI reduction, and will not necessarily be the same as the system EMI reduction.

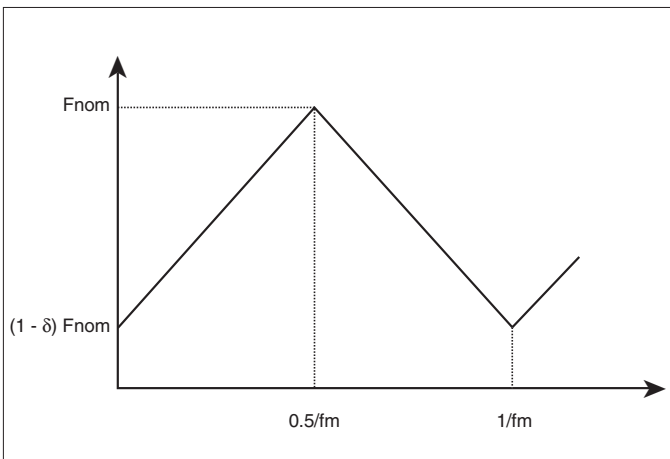

FIGURE 4A. TRIANGLE FREQUENCY MODULATION

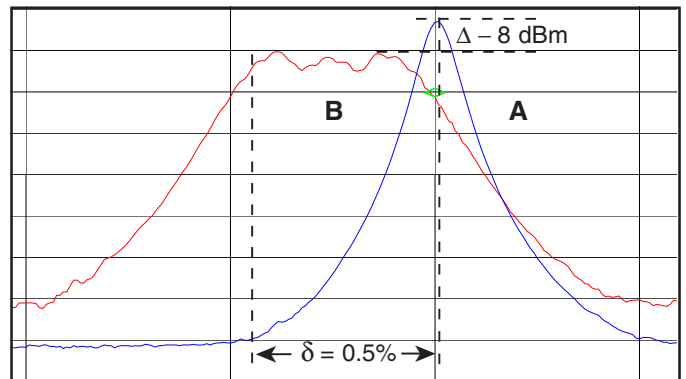

FIGURE 4B. 75MHz CLOCK OUTPUT IN FREQUENCY DOMAIN

(A) SPREAD-SPECTRUM OFF
(B) SPREAD-SPECTRUM ON

TERMINATION FOR 3.3V LVPECL OUTPUT

The clock layout topology shown below is a typical termination for LVPECL outputs. The two different layouts mentioned are recommended only as guidelines.

FOUT and nFOUT are low impedance follower outputs that generate ECL/LVPECL compatible outputs. Therefore, terminating resistors (DC current path to ground) or current sources must be used for functionality. These outputs are designed to drive

50Ω transmission lines. Matched impedance techniques should be used to maximize operating frequency and minimize signal distortion. *Figures 5A and 5B* show two different layouts which are recommended only as guidelines. Other suitable clock layouts may exist and it would be recommended that the board designers simulate to guarantee compatibility across all printed circuit and clock component process variations.

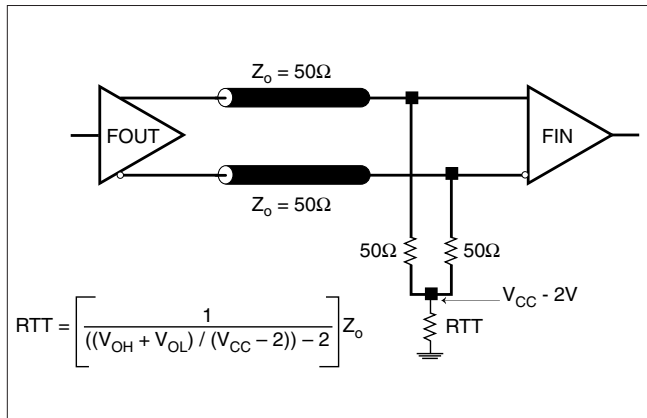

FIGURE 5A. LVPECL OUTPUT TERMINATION

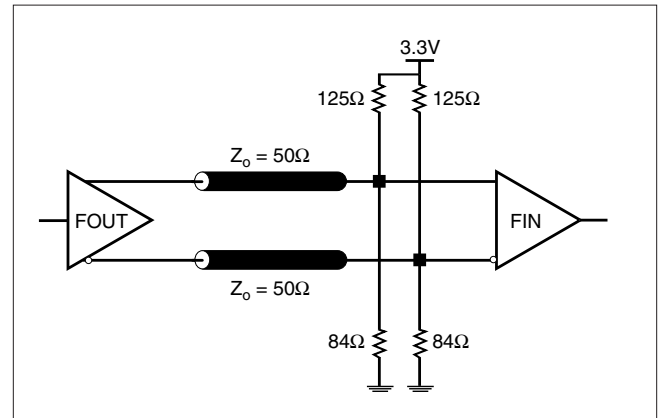

FIGURE 5B. LVPECL OUTPUT TERMINATION

TERMINATION FOR 2.5V LVPECL OUTPUT

Figure 6A and Figure 6B show examples of termination for 2.5V LVPECL driver. These terminations are equivalent to terminating 50Ω to $V_{cc} - 2V$. For $V_{cc} = 2.5V$, the $V_{cc} - 2V$ is very close to ground

level. The R3 in Figure 6B can be eliminated and the termination is shown in Figure 6C.

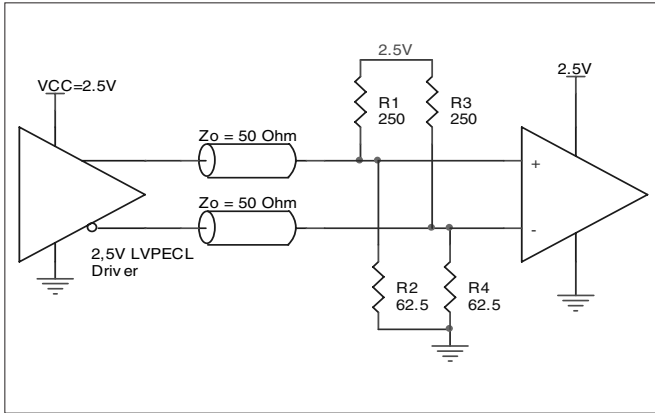

FIGURE 6A. 2.5V LVPECL DRIVER TERMINATION EXAMPLE

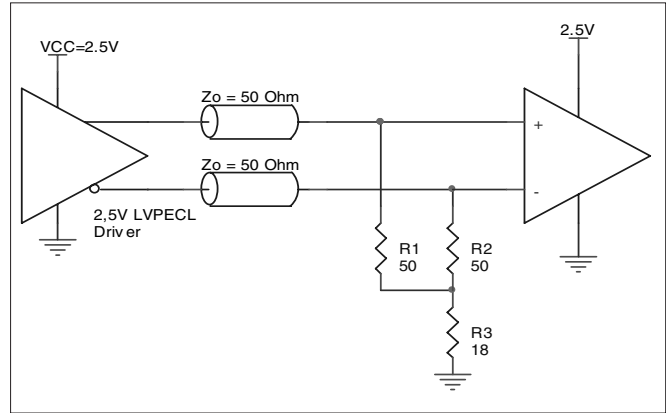

FIGURE 6B. 2.5V LVPECL DRIVER TERMINATION EXAMPLE

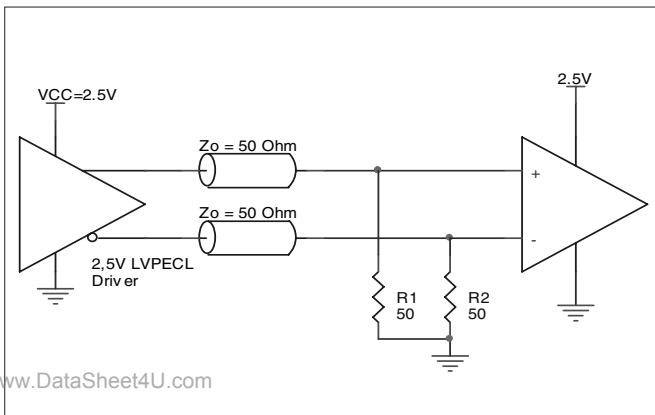

FIGURE 6C. 2.5V LVPECL TERMINATION EXAMPLE

www.DataSheet4U.com

POWER CONSIDERATIONS

This section provides information on power dissipation and junction temperature for the ICS8433011-108. Equations and example calculations are also provided.

1. Power Dissipation.

The total power dissipation for the ICS8433011-108 is the sum of the core power plus the power dissipated in the load(s). The following is the power dissipation for $V_{CC} = 3.3V + 5\% = 3.465V$, which gives worst case results.

NOTE: Please refer to Section 3 for details on calculating power dissipated in the load.

- Power (core)_{MAX} = $V_{CC,MAX} * I_{EE,MAX} = 3.465V * 106mA = 367.29mW$
- Power (outputs)_{MAX} = **30mW/Loaded Output pair**

$$\text{Total Power}_{MAX} (3.465V, \text{ with all outputs switching}) = 370.75mW + 30mW = 397.29mW$$

2. Junction Temperature.

Junction temperature, T_j , is the temperature at the junction of the bond wire and bond pad and directly affects the reliability of the device. The maximum recommended junction temperature for HiPerClockS™ devices is 125°C.

The equation for T_j is as follows: $T_j = \theta_{JA} * Pd_{total} + T_A$

T_j = Junction Temperature

θ_{JA} = Junction-to-Ambient Thermal Resistance

Pd_{total} = Total Device Power Dissipation (example calculation is in section 1 above)

T_A = Ambient Temperature

In order to calculate junction temperature, the appropriate junction-to-ambient thermal resistance θ_{JA} must be used. Assuming air flow of 1 meter per second and a multi-layer board, the appropriate value is 90.5°C/W per Table 6 below.

Therefore, T_j for an ambient temperature of 85°C with all outputs switching is:

$$85^\circ\text{C} + 0.397\text{W} * 90.5^\circ\text{C/W} = 120.9^\circ\text{C}. \text{ This is below the limit of } 125^\circ\text{C}.$$

www.DataSheet4U.com

This calculation is only an example. T_j will obviously vary depending on the number of loaded outputs, supply voltage, air flow, and the type of board (single layer or multi-layer).

TABLE 6. THERMAL RESISTANCE θ_{JA} FOR 8-PIN TSSOP, FORCED CONVECTION

θ_{JA} by Velocity (Meters per Second)			
	0	1	2.5
Multi-Layer PCB, JEDEC Standard Test Boards	101.7°C/W	90.5°C/W	89.8°C/W

3. Calculations and Equations.

The purpose of this section is to derive the power dissipated into the load.

LVPECL output driver circuit and termination are shown in *Figure 7*.

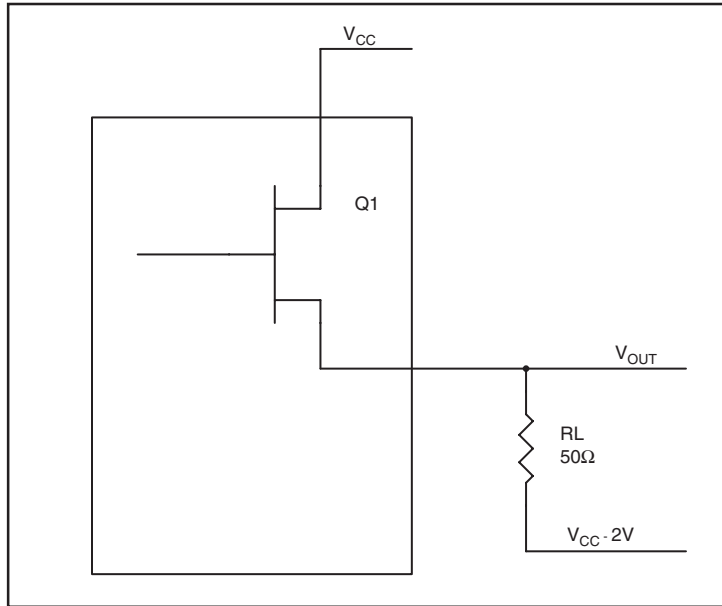

FIGURE 7. LVPECL DRIVER CIRCUIT AND TERMINATION

To calculate worst case power dissipation into the load, use the following equations which assume a 50Ω load, and a termination voltage of $V_{CC} - 2V$.

- For logic high, $V_{OUT} = V_{OH_MAX} = V_{CC_MAX} - 0.9V$

$$(V_{CC_MAX} - V_{OH_MAX}) = 0.9V$$

www.DataSheet4U.com

- For logic low, $V_{OUT} = V_{OL_MAX} = V_{CC_MAX} - 1.7V$

$$(V_{CC_MAX} - V_{OL_MAX}) = 1.7V$$

Pd_H is power dissipation when the output drives high.

Pd_L is the power dissipation when the output drives low.

$$Pd_H = [(V_{OH_MAX} - (V_{CC_MAX} - 2V))/R_L] * (V_{CC_MAX} - V_{OH_MAX}) = [(2V - (V_{CC_MAX} - V_{OH_MAX}))/R_L] * (V_{CC_MAX} - V_{OH_MAX}) = [(2V - 0.9V)/50\Omega] * 0.9V = 19.8mW$$

$$Pd_L = [(V_{OL_MAX} - (V_{CC_MAX} - 2V))/R_L] * (V_{CC_MAX} - V_{OL_MAX}) = [(2V - (V_{CC_MAX} - V_{OL_MAX}))/R_L] * (V_{CC_MAX} - V_{OL_MAX}) = [(2V - 1.7V)/50\Omega] * 1.7V = 10.2mW$$

Total Power Dissipation per output pair = $Pd_H + Pd_L = 30mW$

RELIABILITY INFORMATION

TABLE 7. θ_{JA} VS. AIR FLOW TABLE FOR 8 LEAD TSSOP

θ_{JA} by Velocity (Meters per Second)			
	0	1	2.5
Multi-Layer PCB, JEDEC Standard Test Boards	101.7°C/W	90.5°C/W	89.8°C/W

TRANSISTOR COUNT

The transistor count for ICS843301I-108 is: 3792

PACKAGE OUTLINE - G SUFFIX 8 LEAD TSSOP

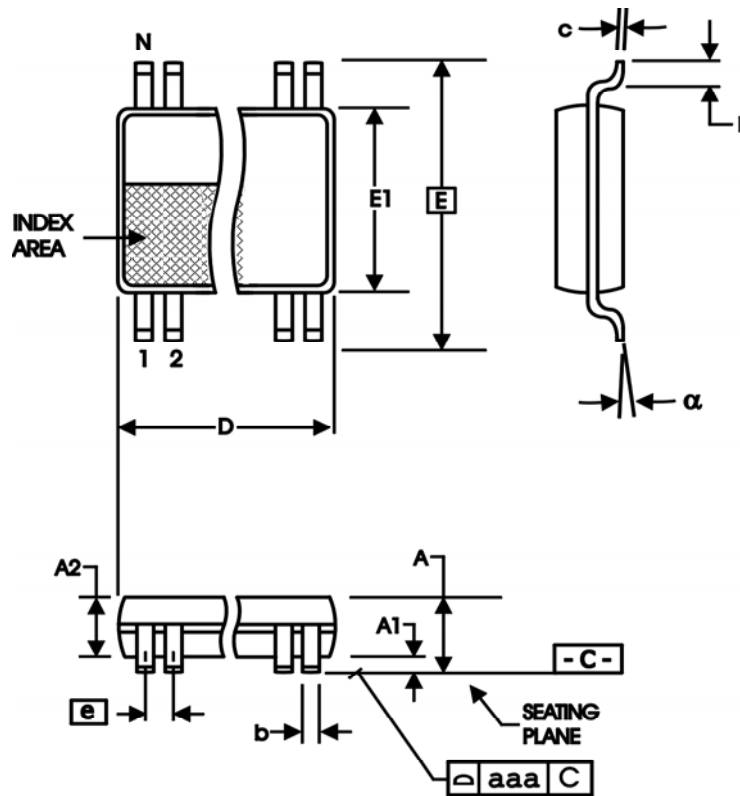

www.DataSheet4U.com

TABLE 8. PACKAGE DIMENSIONS

SYMBOL	Millimeters	
	Minimum	Maximum
N	8	
A	--	1.20
A1	0.05	0.15
A2	0.80	1.05
b	0.19	0.30
c	0.09	0.20
D	2.90	3.10
E	6.40 BASIC	
E1	4.30	4.50
e	0.65 BASIC	
L	0.45	0.75
α	0°	8°
aaa	--	0.10

Reference Document: JEDEC Publication 95, MO-153

TABLE 9. ORDERING INFORMATION

Part/Order Number	Marking	Package	Shipping Packaging	Temperature
843301BGI-108	BI108	8 lead TSSOP	tube	-40°C to 85°C
843301BGI-108T	BI108	8 lead TSSOP	2500 tape & reel	-40°C to 85°C
843301BGI-108LF	B108L	8 lead "Lead-Free" TSSOP	tube	-40°C to 85°C
843301BGI-108LFT	BI08L	8 lead "Lead-Free" TSSOP	2500 tape & reel	-40°C to 85°C

NOTE: Parts that are ordered with an "LF" suffix to the part number are the Pb-Free configuration and are RoHS compliant.

www.DataSheet4U.com

Innovate with IDT and accelerate your future networks. Contact:

www.IDT.com

For Sales

800-345-7015
408-284-8200
Fax: 408-284-2775

For Tech Support

netcom@idt.com
480-763-2056

Corporate Headquarters

Integrated Device Technology, Inc.
6024 Silver Creek Valley Road
San Jose, CA 95138
United States
800 345 7015
+408 284 8200 (outside U.S.)

Asia Pacific and Japan

Integrated Device Technology
Singapore (1997) Pte. Ltd.
Reg. No. 199707558G
435 Orchard Road
#20-03 Wisma Atria
Singapore 238877
+65 6 887 5505

Europe

IDT Europe, Limited
321 Kingston Road
Leatherhead, Surrey
KT22 7TU
England
+44 (0) 1372 363 339
Fax: +44 (0) 1372 378851



www.IDT.com