

General Description

This planar stripe MOSFET has better characteristics, such as fast switching time, low on resistance, low gate charge and excellent avalanche characteristics. It is mainly suitable for DC/DC converters and switching mode power supplies.

FEATURES

- $V_{DSS}=200V$, $I_D=19A$
- Drain-Source ON Resistance : $R_{DS(ON)}=0.18 \Omega$ @ $V_{GS} = 10V$
- $Q_g(\text{typ.})=35nC$

MAXIMUM RATING (Tc=25 °C)

CHARACTERISTIC	SYMBOL	RATING		UNIT	
		KHB019N20P1	KHB019N20F1		
Drain-Source Voltage	V_{DSS}	200		V	
Gate-Source Voltage	V_{GSS}	± 30		V	
Drain Current	@T _C =25 °C	I_D	19	19*	A
	@T _C =100 °C		12.1	12.1*	
	Pulsed (Note1)	I_{DP}	76	76*	
Single Pulsed Avalanche Energy (Note 2)	E_{AS}	250		mJ	
Repetitive Avalanche Energy (Note 1)	E_{AR}	14		mJ	
Peak Diode Recovery dv/dt (Note 3)	dv/dt	4.5		V/ns	
Drain Power Dissipation	Tc=25 °C	P_D	140	50	W
	Derate above 25 °C		1.12	0.4	
Maximum Junction Temperature	T_j	150		°C	
Storage Temperature Range	T_{stg}	-55 ~ 150		°C	
Thermal Characteristics					
Thermal Resistance, Junction-to-Case	R_{thJC}	0.89	2.5	°C/W	
Thermal Resistance, Case-to-Sink	R_{thCS}	0.5	-	°C/W	
Thermal Resistance, Junction-to-Ambient	R_{thJA}	62.5	62.5	°C/W	

* : Drain current limited by maximum junction temperature.

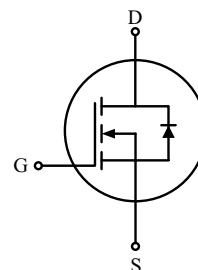
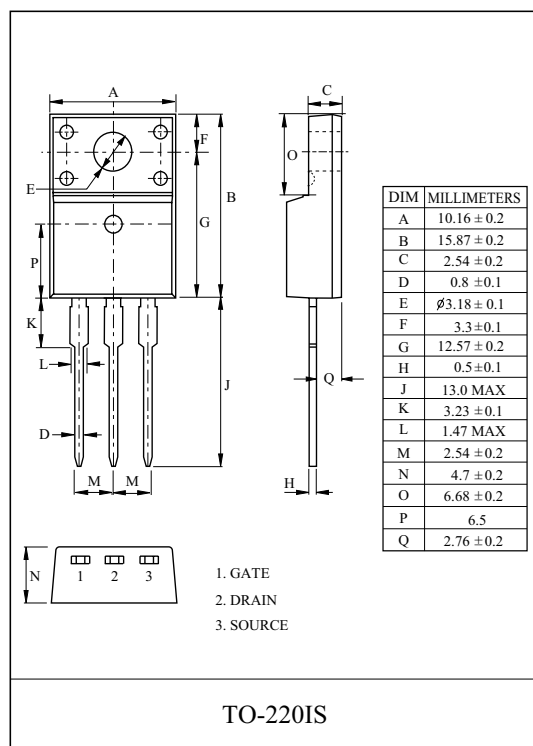
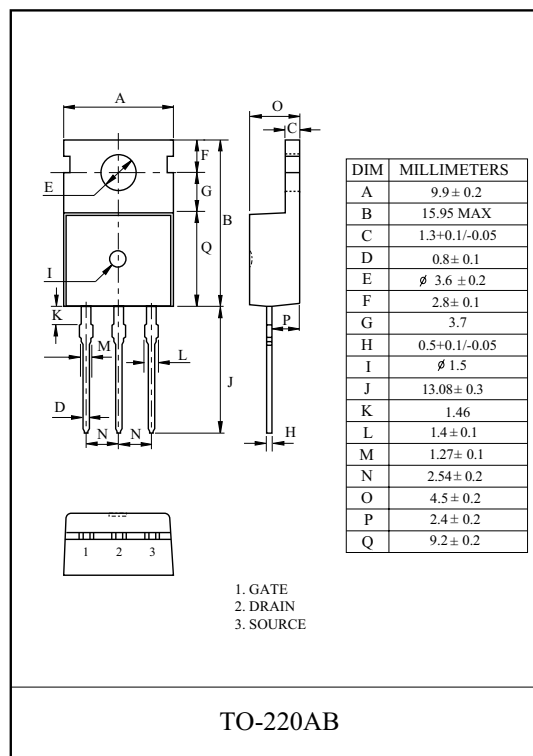

KHB019N20P1/F1

ELECTRICAL CHARACTERISTICS (Tc=25 °C)

CHARACTERISTIC	SYMBOL	TEST CONDITION	MIN.	TYP.	MAX.	UNIT
Static						
Drain-Source Breakdown Voltage	BV_{DSS}	$I_D=250\mu A, V_{GS}=0V$	200	-	-	V
Breakdown Voltage Temperature Coefficient	$\Delta BV_{DSS}/\Delta T_j$	$I_D=250\mu A$, Referenced to 25 °C	-	0.18	-	V/°C
Drain Cut-off Current	I_{DSS}	$V_{DS}=200V, V_{GS}=0V$,	-	-	± 10	μA
Gate Threshold Voltage	V_{th}	$V_{DS}=V_{GS}, I_D=250\mu A$	2	-	4	V
Gate Leakage Current	I_{GSS}	$V_{GS}=\pm 30V, V_{DS}=0V$	-	-	± 100	nA
Drain-Source ON Resistance	$R_{DS(ON)}$	$V_{GS}=10V, I_D=9.5A$	-	0.14	0.18	Ω
Dynamic						
Total Gate Charge	Q_g	$V_{DS}=160V, I_D=19A$ $V_{GS}=10V$ (Note4,5)	-	35	44	nC
Gate-Source Charge	Q_{gs}		-	4.8	-	
Gate-Drain Charge	Q_{gd}		-	18	-	
Turn-on Delay time	$t_{d(on)}$	$V_{DD}=100V$ $R_L=5\Omega$ $R_G=25\Omega$ (Note4,5)	-	12	30	ns
Turn-on Rise time	t_r		-	33	70	
Turn-off Delay time	$t_{d(off)}$		-	130	270	
Turn-off Fall time	t_f		-	75	160	
Input Capacitance	C_{iss}	$V_{DS}=25V, V_{GS}=0V, f=1.0MHz$	-	900	1170	pF
Reverse Transfer Capacitance	C_{rss}		-	213	277	
Output Capacitance	C_{oss}		-	80	104	
Source-Drain Diode Ratings						
Continuous Source Current	I_S	$V_{GS}<V_{th}$	-	-	19	A
Pulsed Source Current	I_{SP}		-	-	76	
Diode Forward Voltage	V_{SD}	$I_S=19A, V_{GS}=0V$	-	-	1.5	V
Reverse Recovery Time	t_{rr}	$I_S=19A, V_{GS}=0V$, $dI_S/dt=100A/\mu s$	-	215	-	ns
Reverse Recovery Charge	Q_{rr}		-	2	-	μC

Note 1) Repetivity rating : Pulse width limited by junction temperature.

Note 2) $L=1mH, I_S=19A, V_{DD}=50V, R_G=25\Omega$, Starting $T_j=25^\circ C$.

Note 3) $I_S \leq 19A, dI/dt \leq 200A/\mu s, V_{DD} \leq BV_{DSS}$, Starting $T_j=25^\circ C$.

Note 4) Pulse Test : Pulse width $\leq 300\mu s$, Duty Cycle $\leq 2\%$.

Note 5) Essentially independent of operating temperature.

KHB019N20P1/F1

$I_D - V_{DS}$

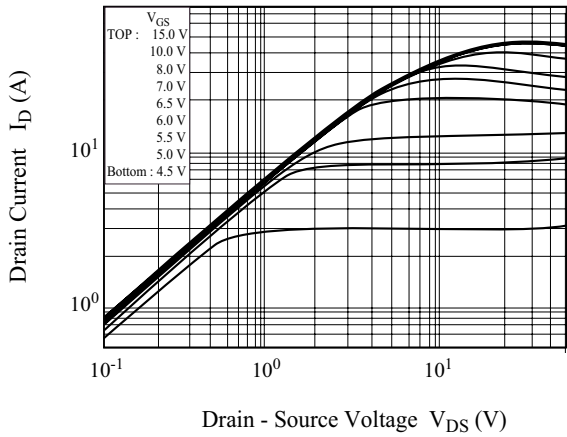

$I_D - V_{GS}$

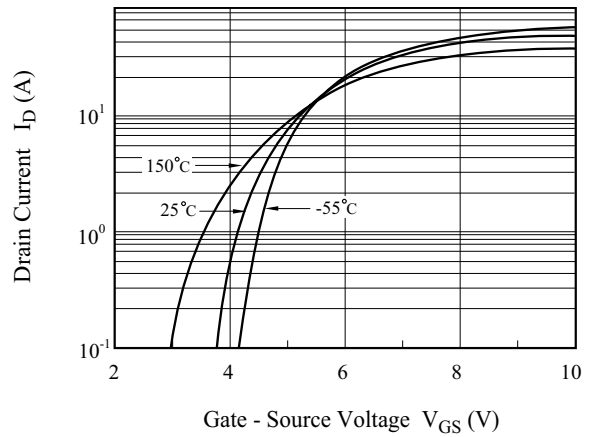

$BV_{DSS} - T_j$

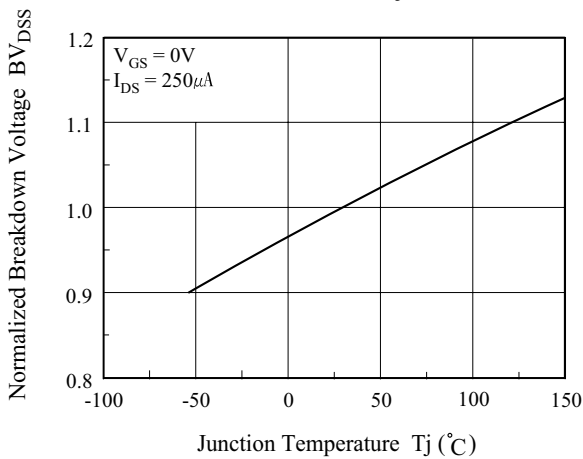

$R_{DS(ON)} - I_D$

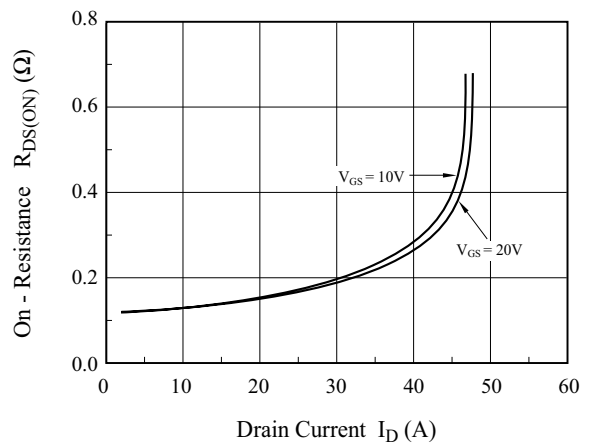

$I_S - V_{SD}$

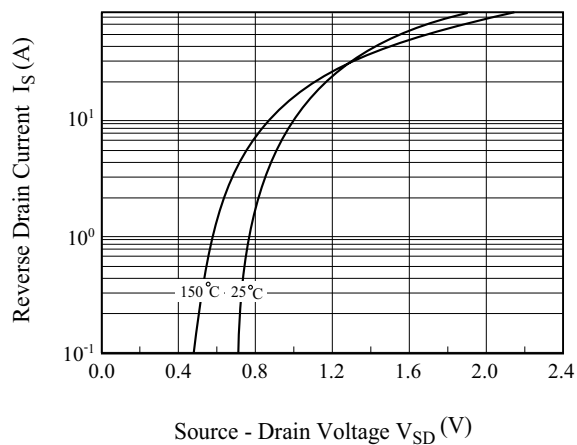

$R_{DS(ON)} - T_j$

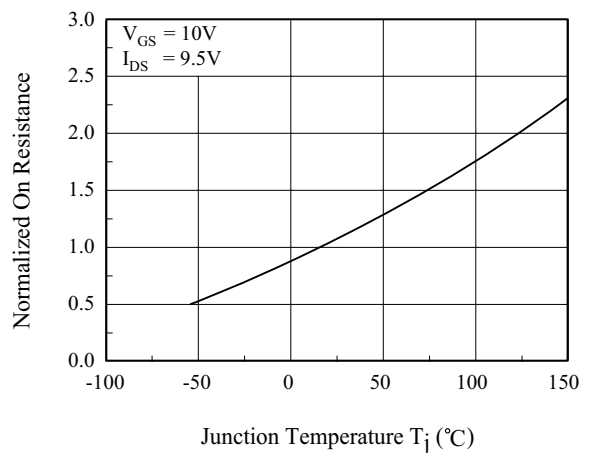

KHB019N20P1/F1

C - V_{DS}

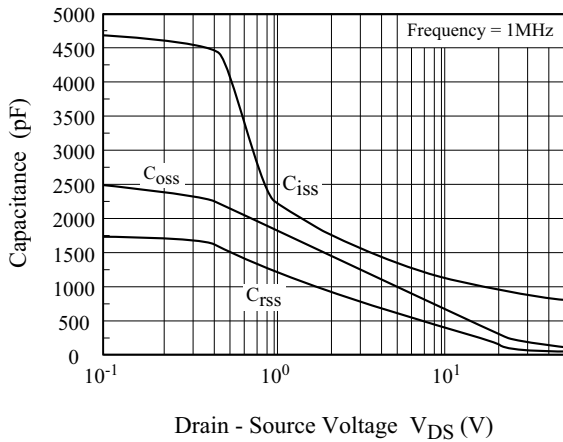

Q_g- V_{GS}

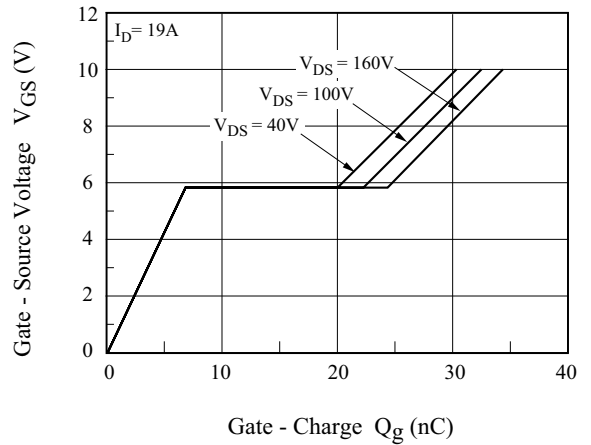

Safe Operation Area

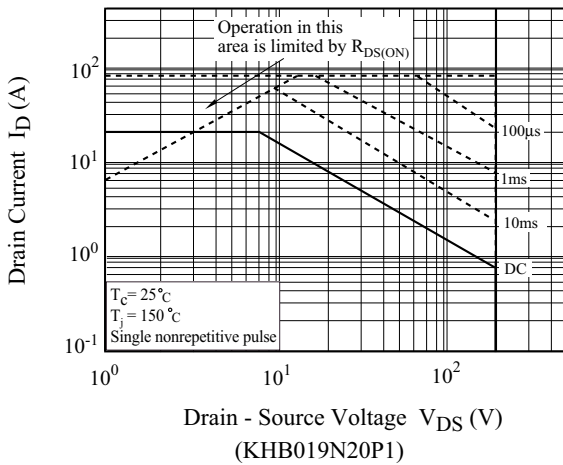

Safe Operation Area

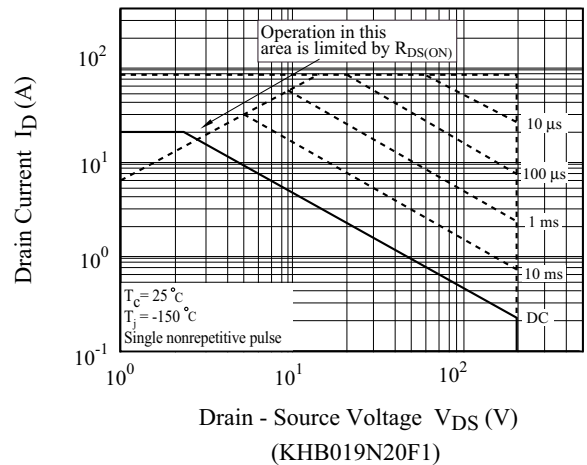

I_D - T_j

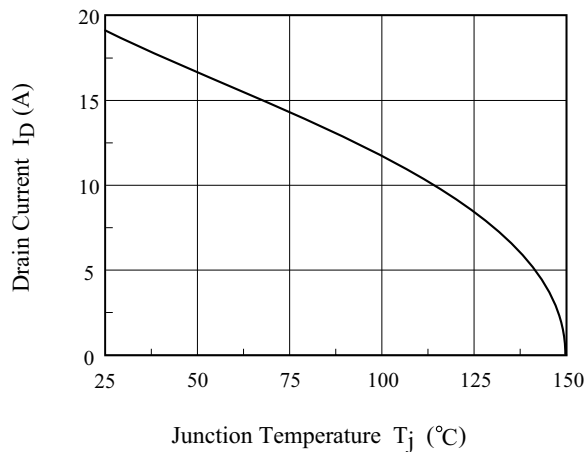

KHB019N20P1/F1

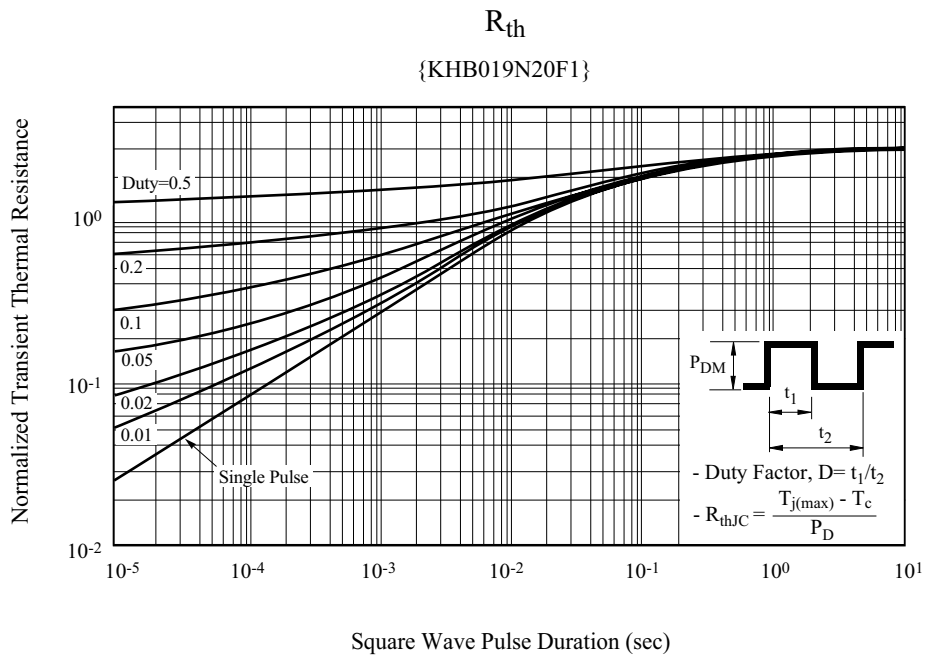
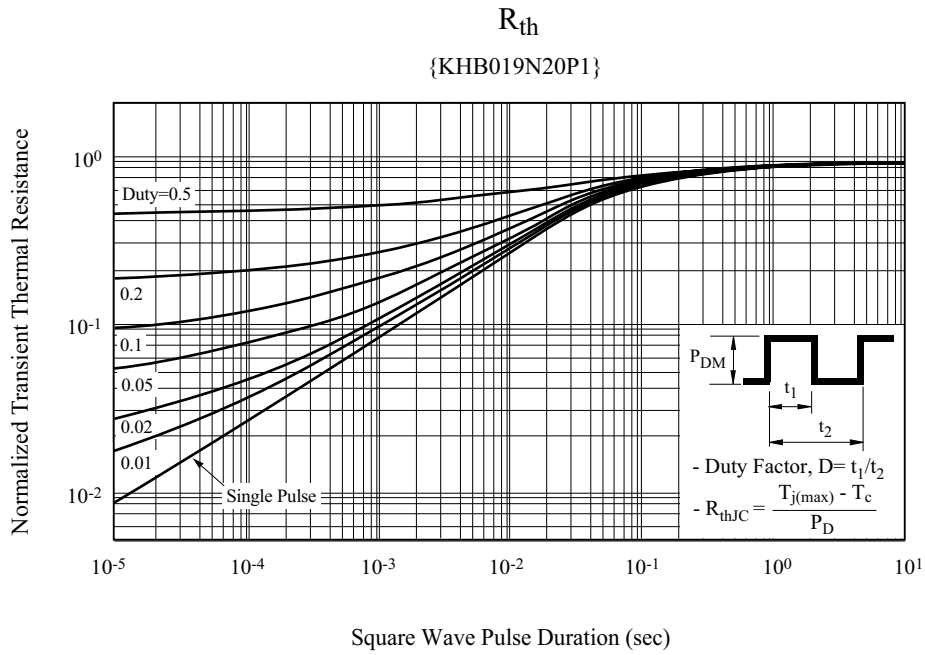

KHB019N20P1/F1

- Gate Charge

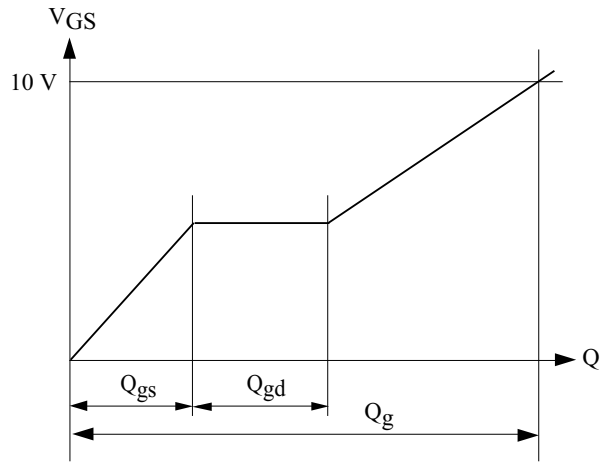
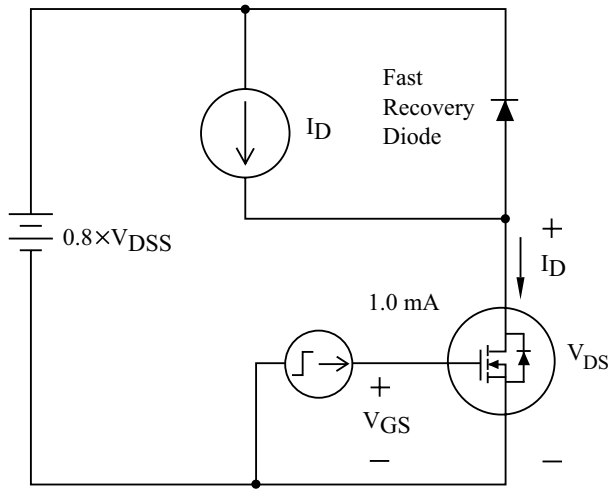

- Single Pulsed Avalanche Energy

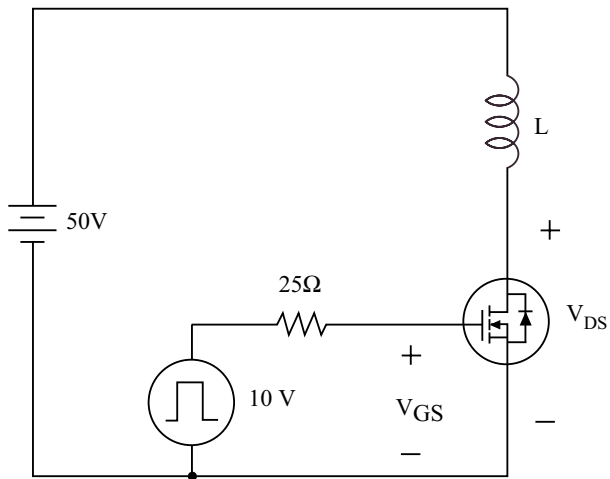

$$E_{AS} = \frac{1}{2} L I_{AS}^2 \frac{BV_{DSS}}{BV_{DSS} - V_{DD}}$$

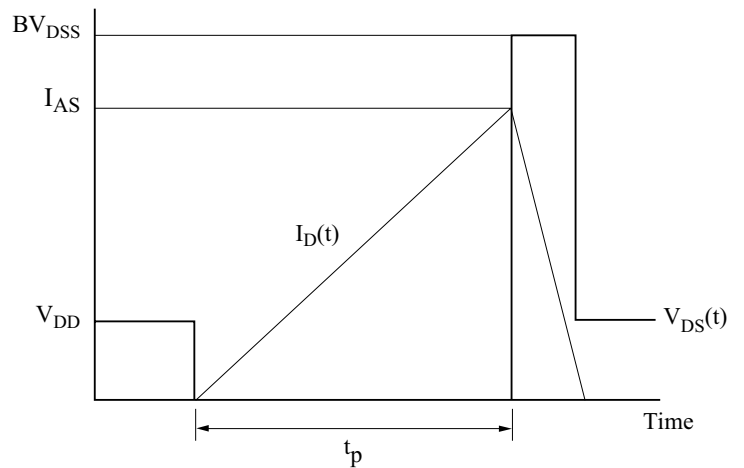

- Resistive Load Switching

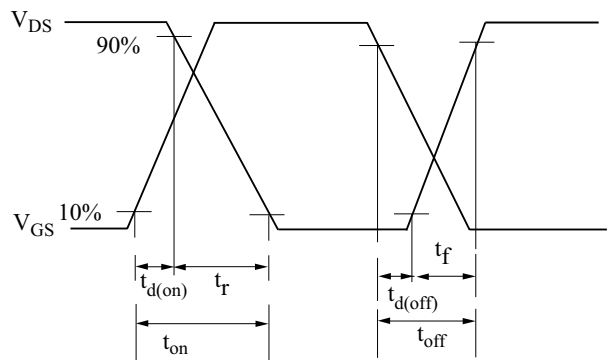
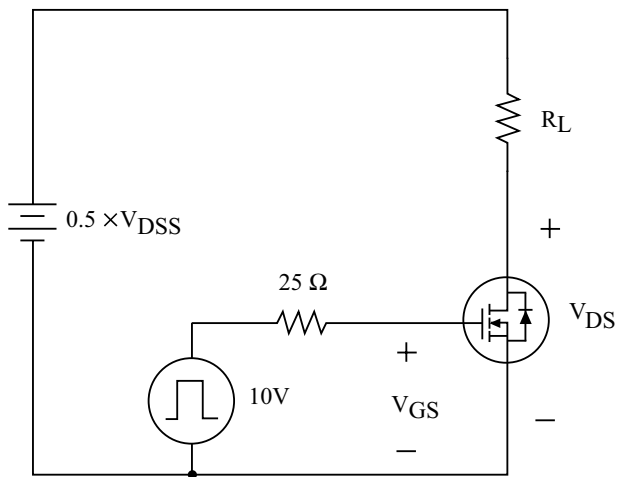

KHB019N20P1/F1

- Source - Drain Diode Reverse Recovery and dv/dt

