



MagAlpha MA780

8-Bit to 12-Bit, Low-Power Angle Sensor with Integrated Wake-Up Angle Detection

DESCRIPTION

The MA780 is a low-power angle sensor that detects the absolute angular position of a permanent magnet, such as a diametrically magnetized cylinder on a rotating shaft. With its power-cycling ability, the sensor is optimized for applications that require low average power. Timing can be controlled via an on-chip clock or external controller. Flags are provided to detect a definable amount of angle change.

The MA780 supports a wide range of magnetic field strengths and spatial configurations. Both end-of-shaft and off-axis (side-shaft mounting) configurations are supported.

On-chip, non-volatile memory (NVM) provides storage for configuration parameters, including the reference zero-angle position, power cycling parameters, and the filter window that affects the output resolution.

The MA780 is available in a QFN-16 (3mmx3mm) package.

FEATURES

- 8-Bit to 12-Bit Resolution Absolute Contactless Angle Encoder
- $<0.5\mu\text{A}$ Current Consumption in Idle Mode
- 10mA Current Consumption in Active Mode
- Angle Detection Interrupt to Wake System
- Supports On-Axis and Off-Axis Operation
- Serial Peripheral Interface (SPI)
- 3.3V Supply
- -40°C to $+125^{\circ}\text{C}$ Operating Temperature
- Available in a QFN-16 (3mmx3mm) Package

APPLICATIONS

- General-Purpose Angle Measurements
- Battery-Powered Devices
- Multi-Turn Encoders
- Low-Power Rotary Knob Interfaces

All MPS parts are lead-free, halogen-free, and adhere to the RoHS directive. For MPS green status, please visit the MPS website under Quality Assurance. "MPS", the MPS logo, and "Simple, Easy Solutions" are trademarks of Monolithic Power Systems, Inc. or its subsidiaries.

TYPICAL APPLICATION

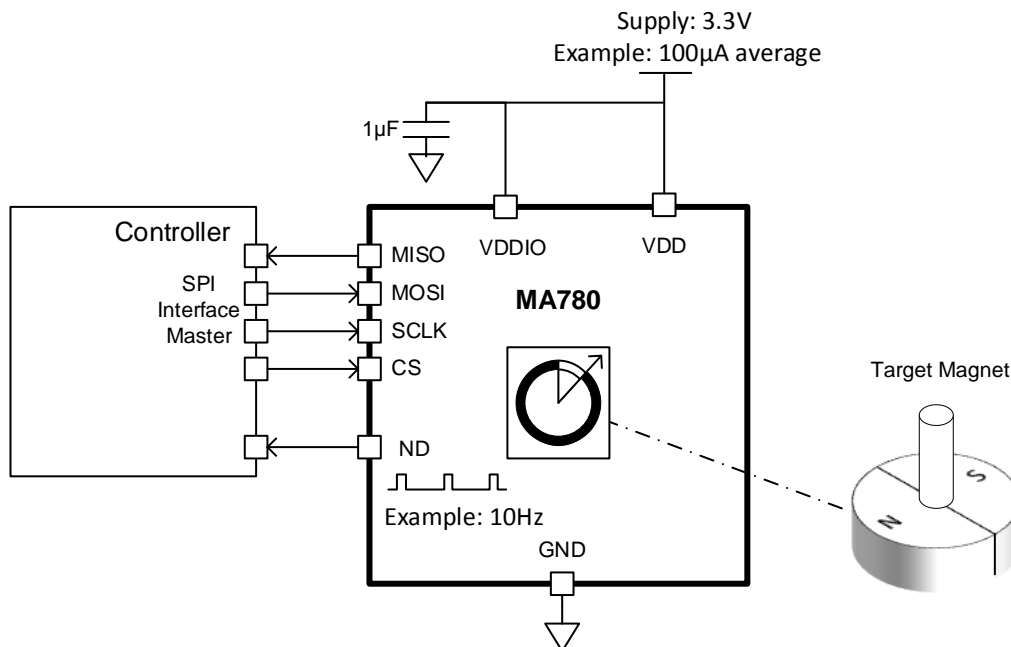

ORDERING INFORMATION

Part Number	Package	Top Marking	MSL Rating
MA780GQ*	QFN-16 (3mmx3mm)	See Below	1

* For Tape & Reel, add suffix -Z (e.g. MA780GQ-Z).

TOP MARKING

BEAY
LLL

BEA: Product code of MA780GQ
 Y: Year code
 LLL: Lot number

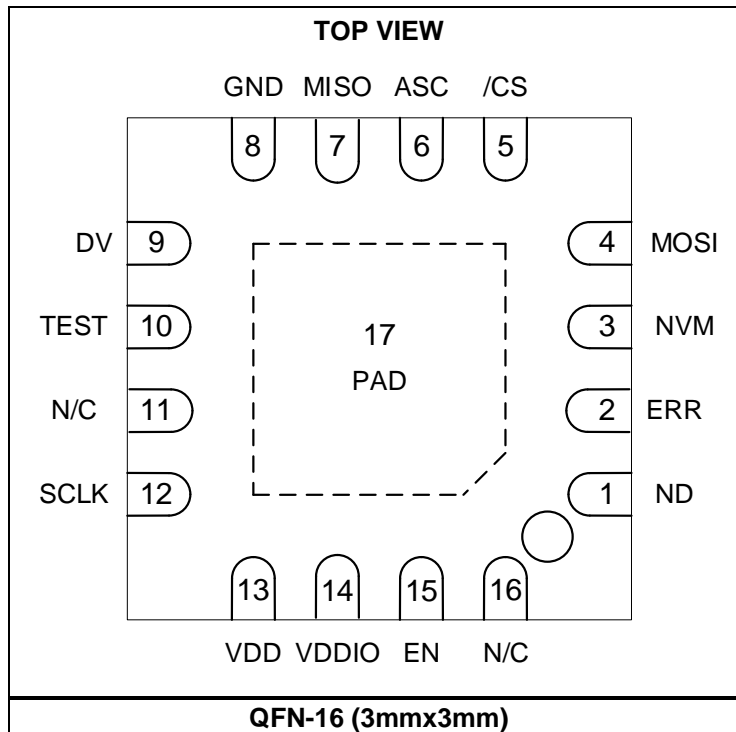
PACKAGE REFERENCE

PIN FUNCTIONS

Pin #	Name	I/O	Description
1	ND	O	New data. In ASC mode, ND indicates when new data is ready to be read. ND also indicates if the displacement exceeds the defined threshold.
2	ERR	O	Error flag.
3	NVM	O	Non-volatile memory (NVM). This pin indicates when the chip is busy accessing the NVM.
4	MOSI	I	Data in (SPI).
5	/CS	I	Chip selection (SPI).
6	ASC	I	Auto-sampling cycle. Connect the ASC pin to GND if it is not used.
7	MISO	O	Data out (SPI). MISO is pulled low when /CS is set to logic 1.
8	GND	N/A	Supply ground.
9	DV	O	Data valid. DV indicates whether the digital filter has been stabilized in active mode.
10	TEST	N/A	Connect to ground.
11	N/C	N/A	No connection. Do not make connections to this pin (internally connected).
12	SCLK	I	Clock (SPI).
13	VDD	N/A	3.3V supply.
14	VDDIO	N/A	1.8V to 3.3V supply for the IO. VDDIO allows for communication at voltages between 1.8V and 3.3V.
15	EN	I	Enable. The EN pin switches the sensor to active mode. Connect EN to GND if it is not used.
16	N/C	N/A	No connection. Do not make connections to this pin (internally connected).

ABSOLUTE MAXIMUM RATINGS ⁽¹⁾

Supply voltage	-0.5V to +4.6V
Input pin voltage (V _I)	-0.5V to +6.0V
Output pin voltage (V _O)	-0.5V to +4.6V
Continuous power dissipation (T _A = 25°C) ⁽²⁾	2.0W
Junction temperature	160°C
Lead temperature	260°C
Storage temperature	-65°C to +150°C

ESD Ratings

Human body model (HBM)	2kV
Charged device model (CDM)	2kV

Recommended Operating Conditions

Supply voltage (V _{DD})	3.0V to 3.6V
I/O supply voltage (V _{DDIO})	1.8V to 3.6V
Operating temperature (T _{OP})	-40°C to +125°C
Applied magnetic field (B)	more than 30mT

Thermal Resistance ⁽³⁾	θ_{JA}	θ_{JC}
QFN-16 (3mmx3mm)	50	12

Notes:

- Exceeding these ratings may damage the device.
- The maximum allowable power dissipation is a function of the maximum junction temperature, T_J (MAX), the junction-to-ambient thermal resistance, θ_{JA}, and the ambient temperature, T_A. The maximum allowable continuous power dissipation at any ambient temperature is calculated by P_D (MAX) = (T_J (MAX) - T_A) / θ_{JA}.
- Measured on JESD51-7, 4-layer PCB.

ELECTRICAL CHARACTERISTICS

$V_{DD} = 3.3V$, $B = 45mT$ to $100mT$, $T_A = -40^{\circ}C$ to $+125^{\circ}C$, unless otherwise noted.

Parameter	Symbol	Condition	Min	Typ	Max	Units
Supply Current						
Active supply current	I_{ACTIVE}			10	12.5	mA
Idle supply current	I_{IDLE}	Below 85°C		0.3	1.9	μA
Absolute Output – Serial						
Effective resolution		$\pm 3\sigma$ deviations from the noise distribution	8		12	bits
Noise RMS		1σ from the noise distribution	0.015		0.2	deg
Refresh rate		Active mode	850	980	1100	kHz
Data output length			16		16	bits
Response Time						
V_{DD} power-up time		After setting V_{DD} at 3.3V		600		μs
Start-up time	t_{START_UP}	From active to data valid while $FW = 0$		35		μs
Latency ⁽⁴⁾		Constant speed propagation delay during t_{ACTIVE} , equals the FW time constant (τ) + $3\mu s$	4		4000	μs
Filter cutoff frequency ⁽⁴⁾	f_{CUTOFF}	Depends on FW	39		160000	Hz
128MHz internal high freq CLK error (affects TACT & filter settling time)		At room temperature	-13		+12	%
Cycle time accuracy		At room temperature	-5		+5	%
Accuracy						
INL at 25°C		At room temperature across the full field range		0.7		deg
INL between -40°C to +125°C ⁽⁵⁾		Across the full temperature range and field range		1.1		deg
Output Drift						
Temperature-induced drift at room temp ⁽⁵⁾				0.01		deg/°C
Temperature-induced variation ⁽⁵⁾		From 25°C to 85°C		0.5		deg
		From 25°C to 125°C		0.7		deg
Induced magnetic field ⁽⁵⁾				0.01		deg/mT
Induced supply voltage ⁽⁵⁾				0.35		deg/V
Digital I/O						
Input high voltage ⁽⁵⁾	V_{IH}	$V_{DDIO} = 3.3V$	2.5		5.5	V
		$V_{DDIO} = 1.8V$	1.2		5.5	V
Input low voltage ⁽⁵⁾	V_{IL}	$V_{DDIO} = 3.3V$	-0.3		+0.8	V
		$V_{DDIO} = 1.8V$	-0.3		+0.4	V
Output low voltage ⁽⁵⁾	V_{OL}	$I_{OL} = 4mA$, $V_{DDIO} = 3.3V$			0.4	V
		$I_{OL} = 4mA$, $V_{DDIO} = 1.8V$			0.4	V
Output high voltage ⁽⁵⁾	V_{OH}	$I_{OL} = 4mA$, $V_{DDIO} = 3.3V$	2.4			V
		$I_{OL} = 4mA$, $V_{DDIO} = 1.8V$	1.2			V
Falling edge slew rate ⁽⁴⁾	t_F	CL = 50pF		0.7		V/ns

Notes:

4) Guaranteed by design.

5) Guaranteed by characteristic testing.

TYPICAL CHARACTERISTICS
 $V_{DD} = 3.3V$, $T_A = 25^\circ C$, unless otherwise noted.

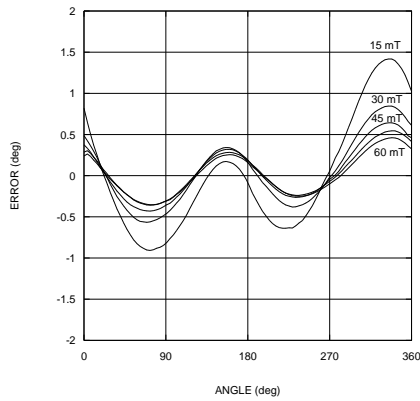
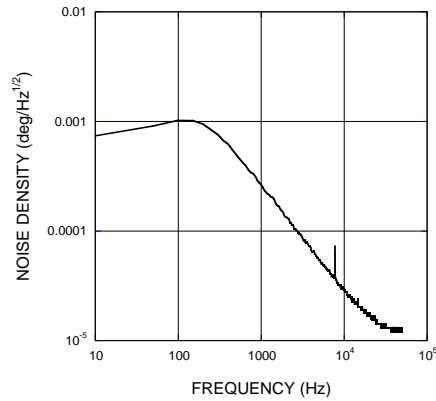
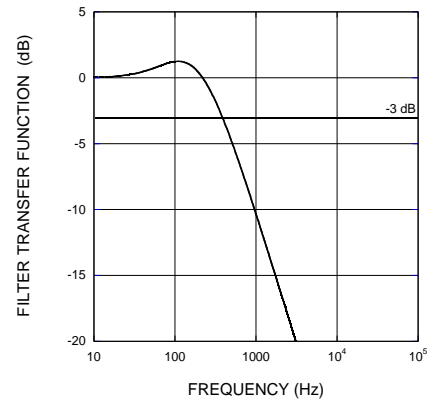
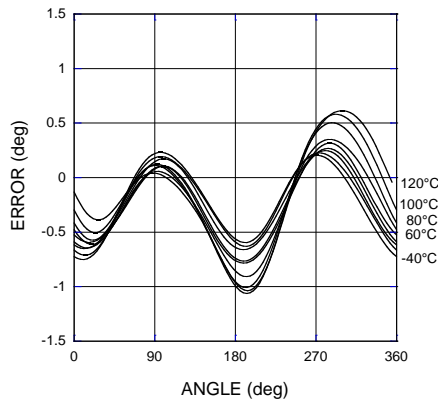
Error Curves

Noise Spectrum
 $B = 50mT$, $W = 10$

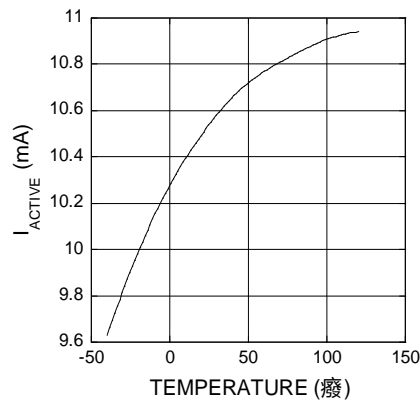
Filter Transfer Function
 $FW = 10$

Error Curves
 $B = 50mT$

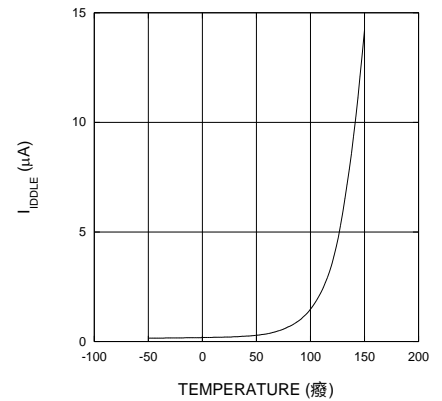
Supply Current

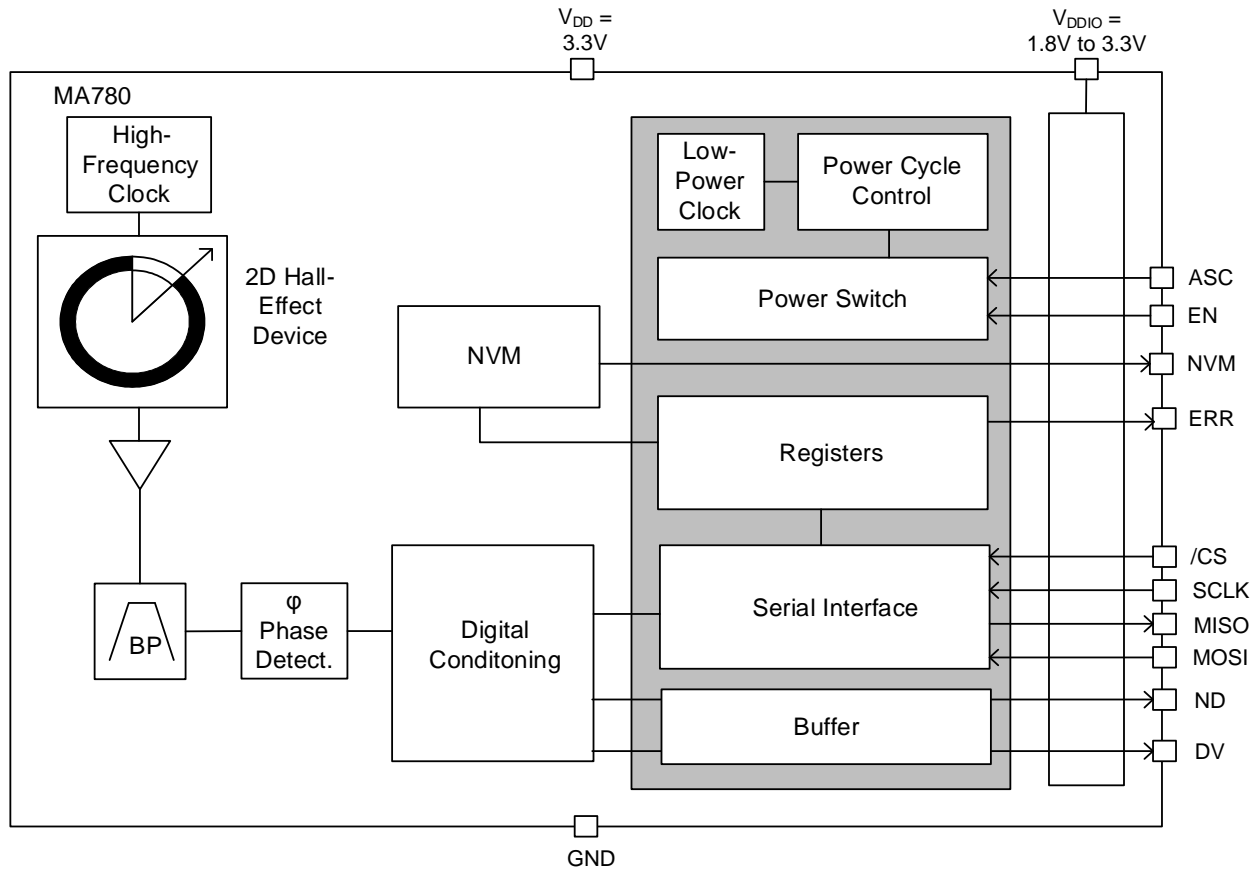
Active mode

Supply Current

Idle mode



FUNCTIONAL BLOCK DIAGRAM

Figure 1: Functional Block Diagram ⁽⁶⁾
Note:

6) Only the gray area operates in idle mode.

OPERATION

Sensor Front End

The magnetic field is detected by the integrated Hall devices located in the center of the package. The angle is measured using the Spinaxis™ method, which directly digitizes the direction of the field without complex arctangent computation or feedback loop-based circuits (interpolators).

The Spinaxis™ method is based on phase detection, and this method generates a sinusoidal signal with a phase that represents the angle of the magnetic field. The angle is then obtained by a time-to-digital converter, which measures the time between the zero crossing of the sinusoidal signal and the edge of a constant waveform (see Figure 2). The time-to-digital is output from the front end to the digital conditioning block.

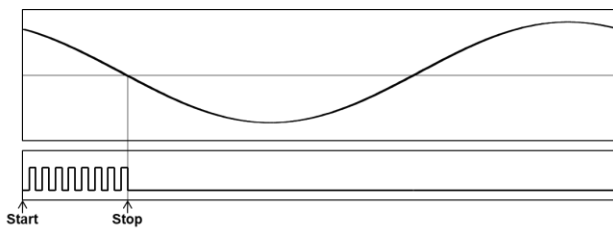

Top: Sine Waveform

Bottom: Clock for Time-to-Digital Converter

Figure 2: Phase Detection Method

The front-end output delivers a digital number that is proportional to the angle of the magnetic field (at the rate of 1MHz) in a straightforward and open-loop manner.

Digital Filtering

The front-end signal undergoes digital filtering treatment to achieve the final effective resolution. The filter transfer function can be calculated with Equation (1):

$$H(s) = \frac{1}{1+Ts} \quad (1)$$

Where τ is the filter time constant, which varies depending on the chosen filter window. Table 14 on page 22 shows the values of τ for different filter window sizes.

To reduce power consumption, the front end and digital filtering function are disabled in idle mode, but the SPI block works continuously to provide the angle.

Sensor – Magnet Mounting

The sensitive volume of the MA780 is confined to a region less than 100 μ m wide in the center of the package (see Figure 3). This area contains multiple integrated Hall devices. The sensor detects the angle of the magnetic field projected in a plane parallel to the package's upper surface. This means that the only measured magnetic field is the in-plane components (i.e. the X and Y components) in the middle point of the package.

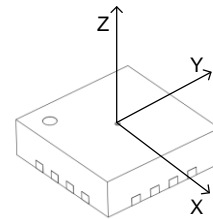

Figure 3: Space Coordinates (Field is Sensed on the XY Plane)

By default, when looking at the top of the package, the angle increases when the magnetic field rotates clockwise. Figure 4 shows the zero angle of a sensor that has not been configured, where the cross indicates the sensitive point. Both the rotation direction and the zero angle can be configured.

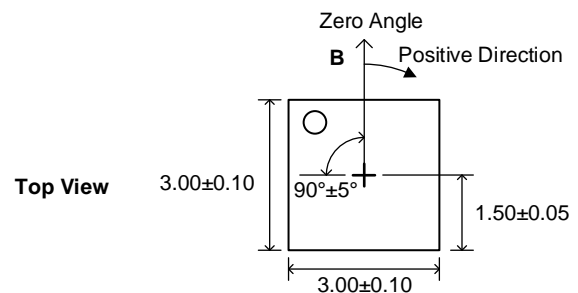
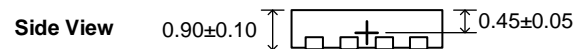

Figure 4: Detection Point and Default Positive Direction

This type of detection provides flexibility for the angular encoder design. The sensor requires that in the center of the package, the field in the XY plane is below 30mT.

The MA780 can work with fields smaller than 30mT, but the linearity and resolution performance may deviate from the specifications under other conditions.

The most straightforward mounting method is to place the MA780 sensor on the rotation axis of a permanent magnet (e.g. a diametrically magnetized cylinder) (see Fig 5).

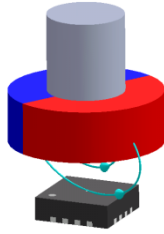

Figure 5: End-of-Shaft Mounting

The recommended magnet is a Neodymium alloy (N35) cylinder with typical dimensions (Ø5x3mm) inserted into an aluminum shaft with a 1.5mm air gap between the magnet and the sensor (surface of package). For good linearity, the sensor should be positioned with a precision of 0.5mm.

If the end-of-shaft position is not available, the sensor can be positioned away from the rotation axis of a cylinder or ring magnet (see Figure 6). In this case, the magnetic field angle is no longer directly proportional to the mechanical angle. The MA780 can be adjusted to compensate for this effect, and to recover the linear relation between the mechanical angle and the sensor output. With multiple pole-pair magnets, the MA780 indicates multiple rotations for each mechanical turn.

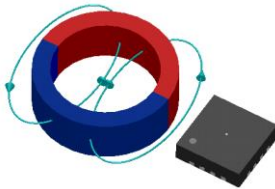

Figure 6: Side-Shaft Mounting

Power Modes

The MA780 has 3 power modes, described below.

1. **Active:** The sensor runs without interruption, and the current consumption is I_{ACTIVE} (see the Electrical Characteristics section on page 4).
2. **Idle:** The sensor front end shuts down, and only the SPI communication interface and memory blocks work. The current consumption is I_{IDLE} (see the Electrical Characteristics section on page 4).

3. **Automatic Sampling Cycle (ASC):** The device automatically switches between active and idle mode.

Table 1: Supply Current with Different Modes

Power Mode	Average Supply Current ($I_{AVERAGE}$)
Active	I_{ACTIVE}
ASC	$I_{IDLE} < I_{AVERAGE} < I_{ACTIVE}$
Idle	I_{IDLE}

Figure 7 shows the timing of a power cycle.

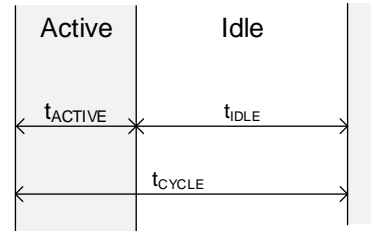

Figure 7: Timing of a Power Cycle

By combining these 3 power modes, the MA780 can be operated in different ways.

Continuous Automatic Sampling Cycle (ASC)

In ASC mode, the on-chip, low-power clock continuously runs to control the sensor's power cycle, according to the active time and cycle time stored in the register.

In the minimum configuration (when ASC mode is set by the internal register), the MA780 only has SPI connections. The master device can communicate with the MA780 at any time, the same way that it does in active mode (see Figure 8). The difference is that in the minimum configuration, the average power consumption is low, and the refresh rate is determined by the TCYC parameter.

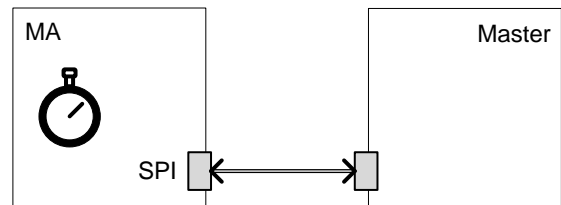
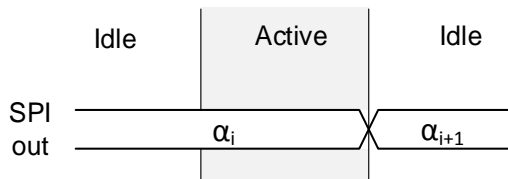

Figure 8: Minimum Configuration for Continuous ASC

The SPI output updates at the end of the active period (see Figure 9).

Figure 9: Signal Timing for ASC Mode

Externally Controlled

The master controls the MA780's power mode via digital input pins (EN and ASC). Switch between any power modes using these pins.

For more details, see Table 15 and Table 16 on page 23.

Power Supply

It is recommended to place a 1 μ F decoupling capacitor close to the sensor with a low impedance path to GND (see Figure 10).

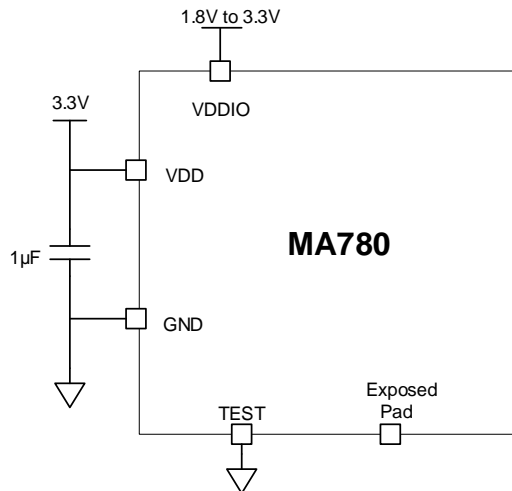
Figure 10: Electrical Mounting and Power Supply Decoupling

Generally, the MA780 works well regardless of whether the exposed pad is connected. If both options are possible, it is recommended not to solder the exposed pad.

Serial Interface

The sensor supports the serial peripheral interface (SPI) to read angles and register configurations.

Serial Peripheral Interface (SPI)

The SPI is a four-wire, synchronous, serial communication interface. The MA780 supports SPI Mode 3 and Mode 0. Table 2 shows the SPI specifications.

Table 2: SPI Specifications

	Mode 0	Mode 3
SCLK Idle State	Low	High
Data Capture	On SCLK rising edge	
Data Transmission	On SCLK falling edge	
/CS Idle State	High	
Data Order	MSB first	

The SPI Mode (0 or 3) is detected automatically by the sensor, and does not require additional action. SPI Mode 0 has a more robust data transfer, so it is recommended to be the default communication mode. The maximum clock rate supported on the SPI is 25MHz. There is no minimum clock rate. Real life data rates depend on the PCB layout and signal trace length. For the SPI timing, see Figure 12, Figure 13, and Table 4 on page 12. Table 3 shows the standard SPI values.

Table 3: SPI Standard

	Mode 0	Mode 3
CPOL	0	1
CPHA	0	1
Data Order (DORD)	0 (MSB first)	

All commands to the MA780 (whether for writing or reading register content) must be transferred through the SPI MOSI pin, and the command must be 16 bits long. See the SPI Communication section on page 13 for more details.

SPI Signal Routing on a PCB

For a reliable data transfer through the SPI bus between the sensor (slave) and the controller (master), special considerations should be made for the PCB design, and the SCLK line in particular. For the best results, follow the guidelines below.

- Properly shield all SPI signals with a GND plane on both sides of each trace, and shield the GND plane underneath the SPI traces.
- Place vias along these traces to connect the top and bottom GND planes.
- To reduce EMI issues, route the SCLK signal away from the other SPI signals and noise sources. The distance should be at least 3 times longer than the SCLK trace width.

- Insert an RC low-pass filter on SCLK (see Figure 11). This RC filter must be located close to the sensor. It is recommended to use a 200Ω serial resistor with a 10pF shunt capacitor in order to have a filter cutting frequency that is about 80MHz.
- Use a star topology for the GND connection, and keep it as direct and short as possible to avoid ground loops.
- Insert RC low-pass filters on the MISO and MOSI signals. The RC filter on MOSI must be located close to the controller, while the filter on MISO must be located close to the sensor. It is recommended to use a 200Ω resistor with a 10pF capacitor.
- Avoid significant trace length mismatch between the SPI signals, especially between the MISO, MOSI, and SCLK signals.
- If possible, avoid placing vias on the SCLK signal.

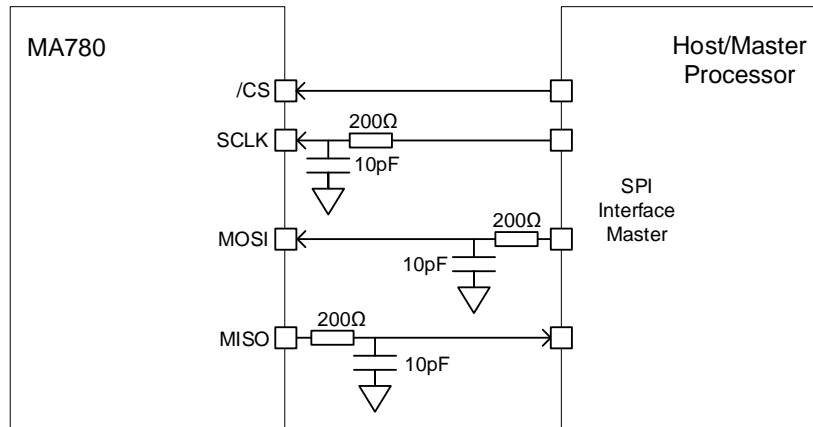
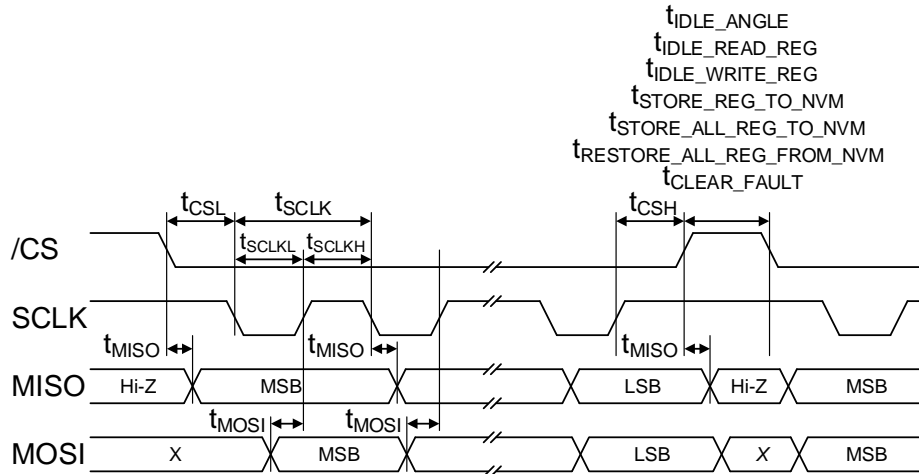
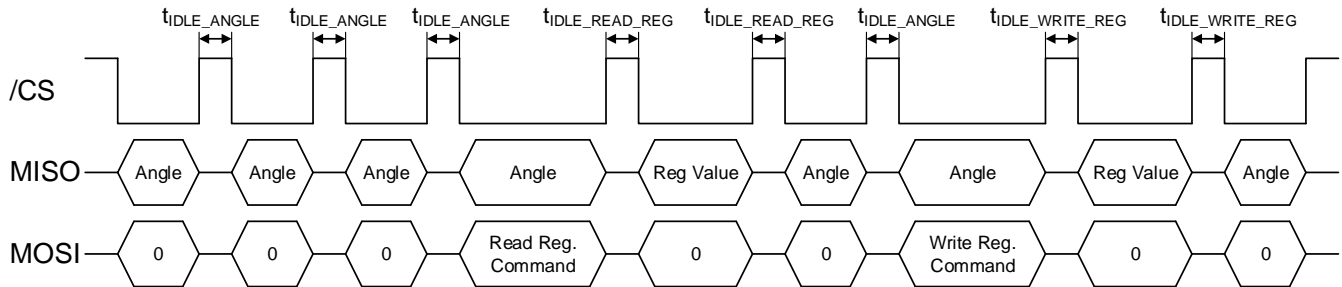

Figure 11: Example of an RC Low-Pass Filter on the SPI Signals

Figure 12: SPI Timing Diagram (Mode 3)

Figure 13: Minimum Idle Time
Table 4: SPI Timing

Parameter ⁽⁷⁾	Description	Min	Max	Unit
t _{IDLE_ANGLE}	Idle time between two subsequent angle transmissions	120		ns
t _{IDLE_READ_REG}	Idle time before and after a register readout	120		ns
t _{IDLE_WRITE_REG}	Idle time before and after a register write.	120		ns
t _{STORE_REG_TO_NVM}	Time required to store a register value to the NVM	23		ms
t _{STORE_ALL_REGT_O_NVM}	Time required to store all register values to the NVM	704		ms
t _{RESTORE_ALL_REG_FROM_NVM}	Time required to restore all register values from the NVM	240		µs
t _{CLEAR_FAULT}	Time required to clear the fault flags (register 26)	40		ns
t _{CSL}	Time between /CS falling edge and SCLK falling edge	120		ns
t _{SCLK}	SCLK period	40		ns
t _{SCLKL}	Low level of the SCLK signal	20		ns
t _{SCLKH}	High level of the SCLK signal	20		ns
t _{CSH}	Time between the SCLK rising edge and /CS rising edge	20		ns
t _{MISO}	SCLK falling edge to data output valid		15	ns
t _{MOSI}	Data input valid to SCLK reading edge	15		ns

Note:

7) All values are guaranteed by design.

SPI Communication

Users can accomplish the following using the SPI:

- Read angle
- Read register
- Write register
- Store a single register to NVM
- Store all registers to NVM
- Restore all registers from NVM
- Clear error flags

SPI Read Angle

Every 1µs, new data is transferred into the output buffer. The master device initiates this process by pulling /CS low. When a trigger event is detected, the data remains in the output buffer until the /CS signal is de-asserted (see Table 5).

Table 5: Sensor Data Timing

Event	Action
/CS falling edge	Start reading and freeze the output buffer
/CS rising edge	Release the output buffer

Figure 14 shows a diagram of a full SPI angle reading.

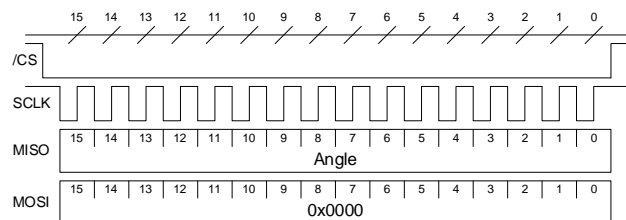

Figure 14: Diagram of a Full 16-Bit SPI Angle Reading

Figure 15 shows a partial SPI angle reading.

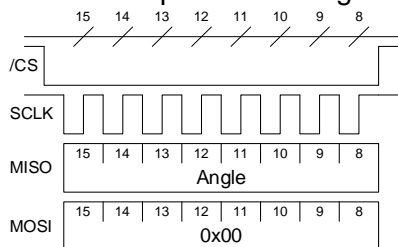
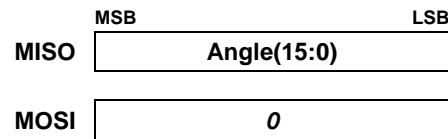

Figure 15: Diagram of a Partial 8-Bit SPI Angle Reading

A full angle reading requires 16 clock pulses. The sensor's MISO line then returns the following:



If less resolution is sufficient, the angle can be read by sending fewer clock counts (since the MSB is first). If the reading cycle is shorter than the refresh time, the MA780 continues sending the same data until the data refreshes (for the refresh rate, see the Electrical Characteristics section on page 4).

SPI Read Register

A read register operation consists of two 16-bit frames. The first frame sends a read request, which contains the 3-bit read command (010) followed by the 5-bit register address. The last 8 bits of the frame must all be set to 0. The second frame returns the 8-bit register value (MSB byte) with an 8-bit angle value.

First 16-bit SPI frame (read request):

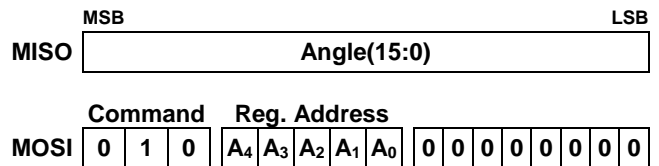

Second 16-bit SPI frame (response):

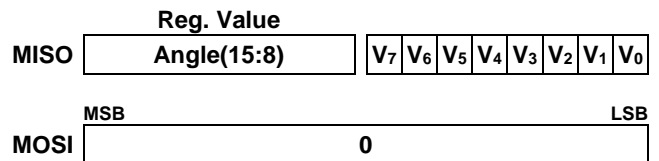

For example, to check the value of the ERRPAR parameter (parity error on register write command), read register 26 (bit[3]) by sending the following first frame:

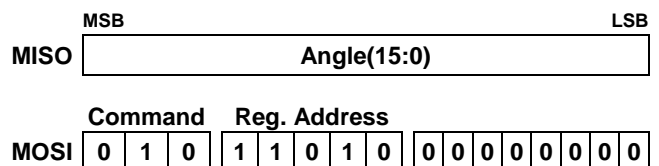

In the second frame, the MA780 replies:

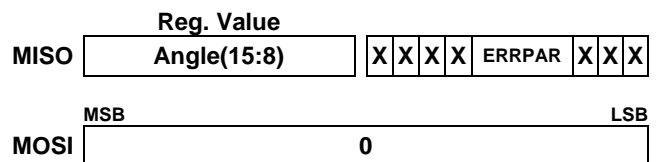

Figure 16 shows a complete read register transmission overview. Figure 17 shows a complete read register example.

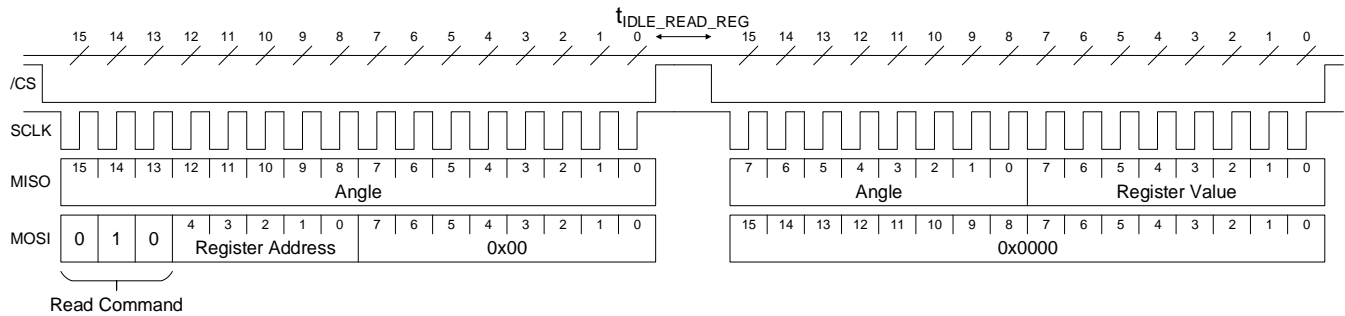

Figure 16: Two 16-Bit Frames Read Register Operation

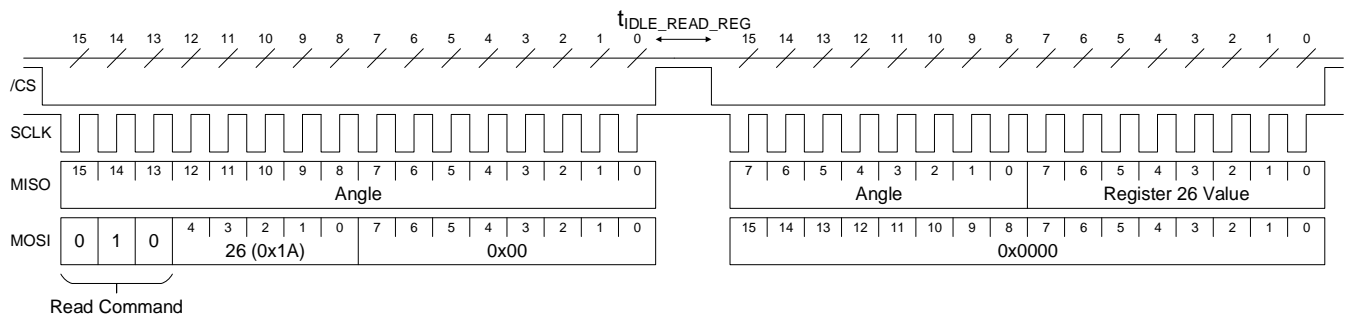
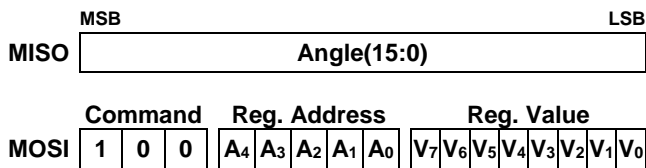

Figure 17: Read the Status Byte in Register 26

SPI Write Register

A write register operation is made of two 16-bit frames. The first frame sends a write request, which contains the 3-bit write command (100) followed by the 5-bit register address and the 8-bit value (MSB first). The second frame returns the newly written register value (acknowledge) with an 8-bit angle value. In ASC mode, if the write command is sent when the sensor is in a transition from an active state to an idle state, the write command might fail. Therefore, it is recommended to verify that the write command was successful by reading the acknowledgement.

The first 16-bit SPI frame (write request) is as follows:



The second 16-bit SPI frame (response) is as follows:

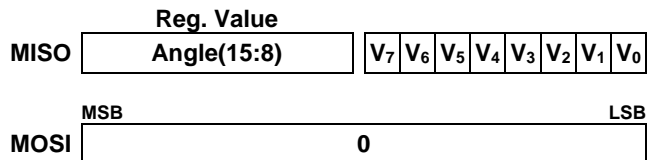

The readback register content can be used to verify the register configuration. Figure 18 shows a complete transmission overview.

For example, to set the value of the output rotation direction (RD) to counterclockwise (RD bit = logic 1), write register 9 by sending the following first frame:

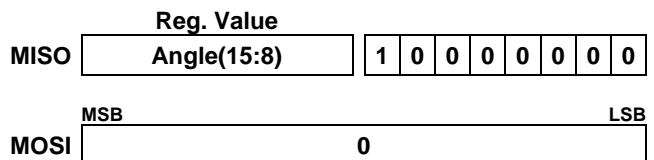
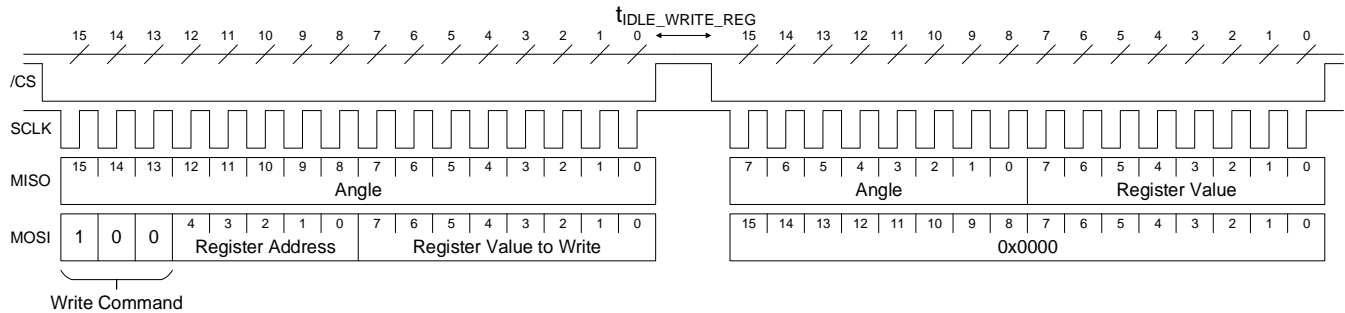
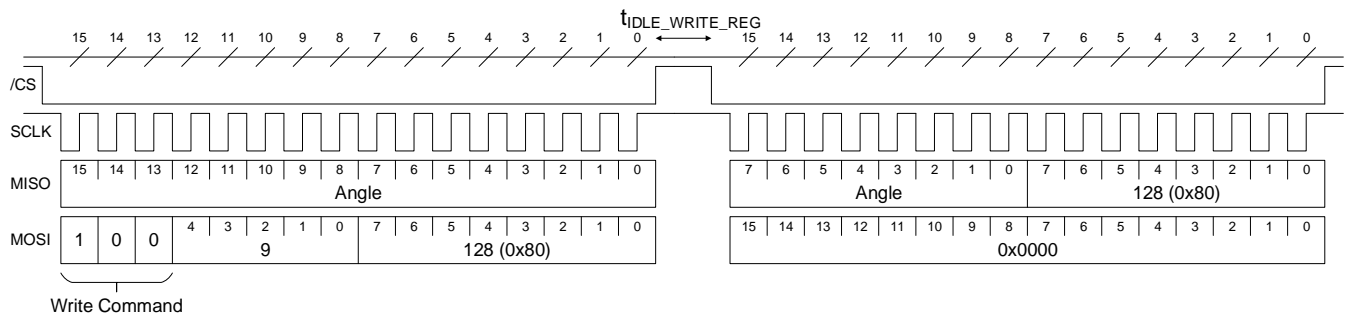

Figure 19 shows a complete example.

Figure 18: Overview of Two 16-Bit Frame Write Register Operation

Figure 19: Write Output Rotation Direction (RD) to Counterclockwise (High), on Register 9, Bit 7

Non-Voltage Memory (NVM) Operations

The sensor contains non-volatile memory (NVM) to store the chip configurations during shutdown. The values stored in the NVM are automatically loaded into the sensor’s registers during start-up.

It is also possible to manually force the restoration of the NVM values to the registers by using the Restore All Register Values SPI command.

The registers can be copied to the NVM using two SPI commands:

1. Store a Single Register to NVM
2. Store All Registers to NVM

The NVM is guaranteed to handle 1,000 write cycles at 25°C.

Users must first write the desired configuration to the registers by using the write register commands, and then call one of the store commands to save one or all registers to the NVM.

These commands are ignored if the NVM is busy executing a previously received command. To

check that the NVM is available and ready to receive a new command, check the NVM pin level.

The NVM pin is set to high when the NVM is busy. Store and restore commands are processed when the NVM pin is cleared (low) (see Figure 20).

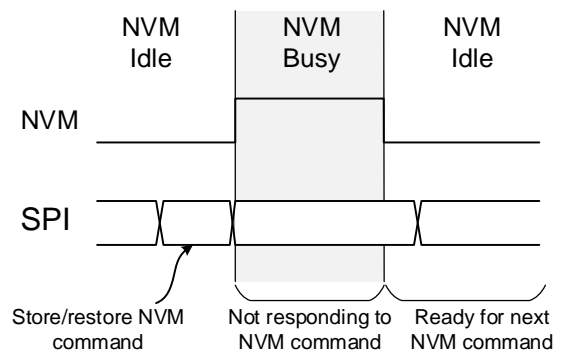
Figure 20: Signal Timing for NVM Access

SPI Store a Single Register to NVM

The current value of a specific register can be stored in the NVM. This command is ignored if the NVM is busy executing a previously received command (see Figure 21).

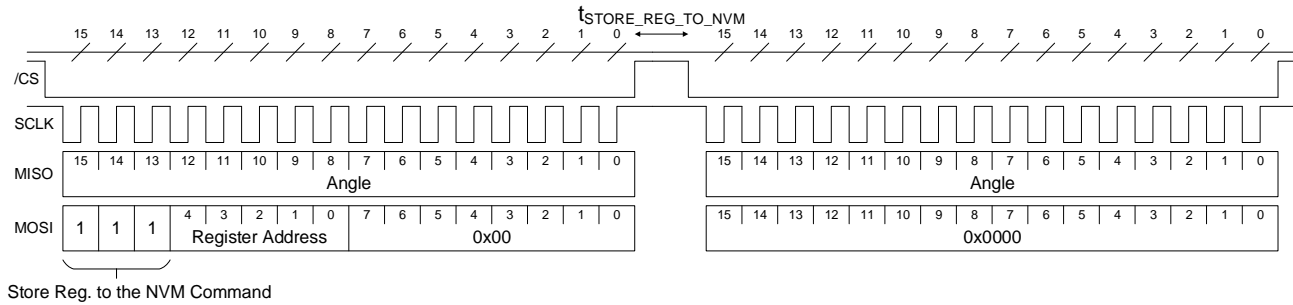
Figure 21: Overview of Two 16-Bit Frames Store Register to NVM Operation

SPI Store All Registers to NVM

The user can store the current value of all registers in the NVM (see Figure 22). This

command is ignored if the NVM is busy executing a previously received command.

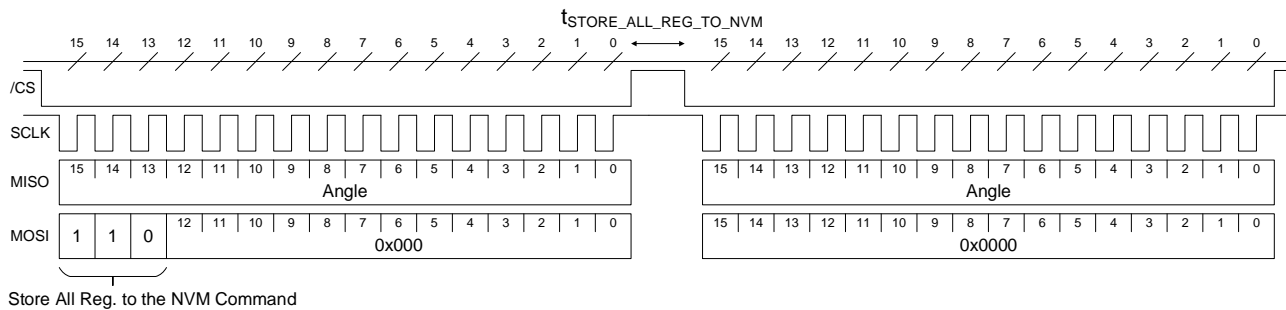
Figure 22: Overview of Two 16-Bit Frames Store All Registers to NVM Operation

SPI Restore All Registers from NVM

The user can restore the value of all registers from the NVM. This operation is done

automatically during each start-up (see Figure 23). This command is ignored if the NVM is busy executing a previously received command.

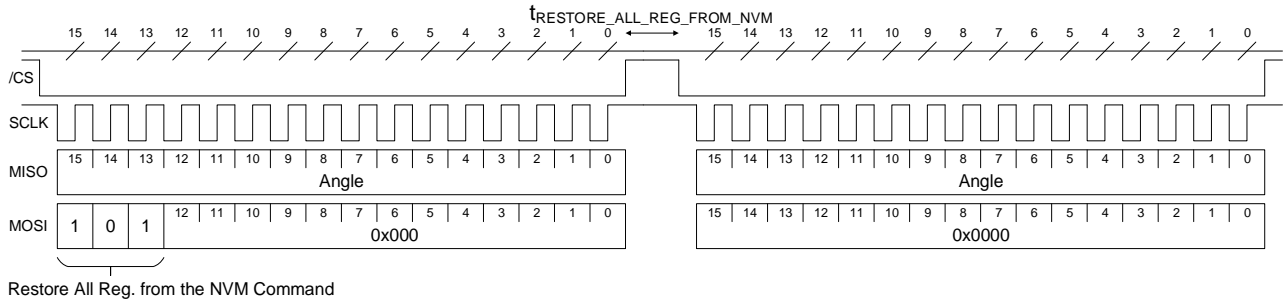
Figure 23: Overview of Two 16-Bit Frames Restore All Registers from NVM Operation

SPI Clear Error Flags

The error flag on the ERR pin (reset to 0), we well as the error flags in register 26, can be

cleared using the SPI Clear Error Flags command (see Figure 24).

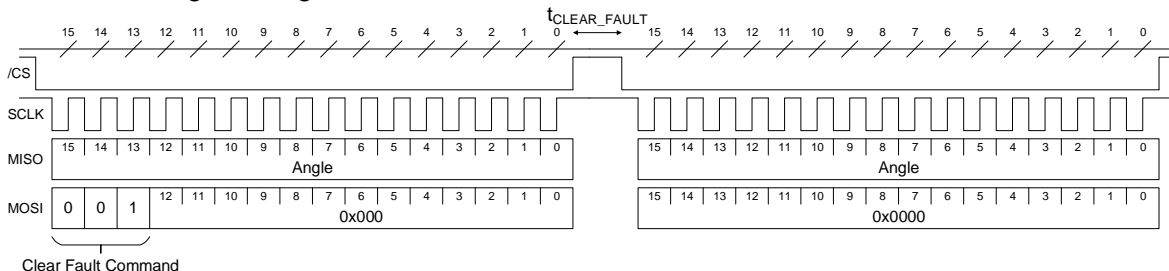

Figure 24: Overview of Two 16-Bit Frames Clear Error Flags Operation

Table 6 shows a summary of all SPI commands.

Table 6: SPI Command List Overview

Command Name	Command Bits[15:13]	Register Address Required?	Register Value Required?	Returned Value
Read Angle	000	No	No	16-bit angle
Read Register	010	Yes	No	8-bit angle + register value
Write Register	100	Yes	Yes	8-bit angle + register value
Store Single Register to NVM	111	Yes	No	16-bit angle
Store All Registers to NVM	110	No	No	16-bit angle
Restore All Registers from NVM	101	No	No	16-bit angle
Clear Error Flags	001	No	No	16-bit angle

REGISTER MAP
Table 7: Register Map ⁽⁸⁾

No	Hex	Bin	Bit[7] (MSB)	Bit[6]	Bit[5]	Bit[4]	Bit[3]	Bit[2]	Bit[1]	Bit[0] (LSB)
0	0x0	00000	Z[7:0]							
1	0x1	00001	Z[15:8]							
2	0x2	00010	BCT[7:0]							
3	0x3	00011	-	-	-	-	-	-	ETY	ETX
4	0x4	00100	TCYC[7:0]							
5	0x5	00101	TCYC[15:8]							
7	0x7	00111	TACT[7:0]							
8	0x8	01000	THR[7:0]							
9	0x9	01001	RD	-	-	-	-	-	-	-
10	0xA	01010	REF[7:0]							
11	0xB	01011	ASCR	ASC	AUTACT	0	0	0	0	0
14	0xE	01110	FW[3:0]							
22	0x16	10110	0	0	0	MULTI[1:0]		0	0	1
26	0x1A	11010	-	-	-	-	ERRPAR	ERRMEM	ERRNVM	-

Note:

8) Register 26 contains error flag output bits (read-only).

Table 8: Default Factory Values

No	Hex	Bin	Bit[7] MSB	Bit[6]	Bit[5]	Bit[4]	Bit[3]	Bit[2]	Bit[1]	Bit[0] LSB
0	0x0	00000	0	0	0	0	0	0	0	0
1	0x1	00001	0	0	0	0	0	0	0	0
2	0x2	00010	0	0	0	0	0	0	0	0
3	0x3	00011	0	0	0	0	0	0	0	0
4	0x4	00100	0	1	1	0	1	1	1	0
5	0x5	00101	0	0	0	0	0	0	0	0
7	0x7	00111	1	0	0	0	0	1	1	1
8	0x8	01000	0	0	0	0	0	0	0	0
9	0x9	01001	0	0	0	0	0	0	0	0
10	0xA	01010	0	0	0	0	0	0	0	0
11	0xB	01011	1	1	1	0	0	0	0	0
14	0xE	01110	1	0	0	1	0	0	0	0
22	0x16	10110	0	0	0	0	0	0	0	1

Table 9: Configuration Parameters

Parameters	Symbol	# of Bits	Description	See Table
Zero setting	Z	16	Sets the zero position	10
Bias current trimming	BCT	8	For side-shaft configuration: reduces the bias current of the X or Y Hall device	12
Enable trimming X	ETX	1	Biased current trimmed in the X-direction Hall device	13
Enable trimming Y	ETY	1	Biased current trimmed in the Y-direction Hall device	13
Cycle time	TCYC	16	ASC mode: time for active and idle cycle	18
On time	TACT	8	ASC mode: active time	17
Threshold	THR	8	ASC mode: Threshold for change detection	19
Rotation direction	RD	1	Determines the sensor's positive direction	11
Reference	REF	1	ASC mode: angle of reference for change detection	20
Auto-TACT	AUTACT	1	ASC mode: automatically determines the active time	24
Automatic sampling cycle	ASC	1	Enables ASC mode	15
ASC register driven	ASCR	1	Allows ASC mode to be enabled via register setting	15
Filter window	FW	4	Size of the filter window. Determines the resolution, settling time, and latency	14
Multi-turns	MULTI	2	Sets the turn counter	21
Parity error	ERRPAR	1	Parity check for data sent to the device	22
Memory error	ERRMEM	1	Error when two successive NVM commands are too close to one another	22
CRC error	ERRNVM	1	CRC check for loading data from the NVM	22

REGISTER SETTINGS

Zero Setting

The zero position of the MA780 (a_0) can be configured with 16 bits of resolution. The angle outputted by the MA780 (a_{OUT}) can be calculated with Equation (2):

$$a_{OUT} = a_{RAW} - a_0 \quad (2)$$

Where a_{RAW} is the raw angle provided by the MA780 front end.

The parameter Z[15:0] is the zero-angle position coded on 16 bits (see Table 10).

Table 10: Zero Setting Parameter

Z[15:0]	a_0 (deg)
0	0
1	0.005
2	0.011
...	...
65534	359.989
65535	359.995

Rotation Direction

When looking at the top of the package, the angle increases when the magnetic field rotates clockwise (CW) by default (see Figure 25).

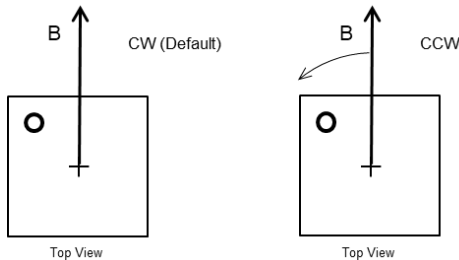

Figure 25: Positive Rotation Direction of the Magnetic Field

Table 11 lists how to designate the rotation direction.

Table 11: Rotation Direction Parameter

RD	Positive Direction
0	Clockwise (CW)
1	Counterclockwise (CCW)

BCT Settings (Bias Current Trimming)

Side Shaft

When the MA780 is mounted on the side of the magnet, the relationship between the field angle and mechanical angle is no longer linear. This effect is related to the fact that the tangential

magnetic field is usually smaller than the radial field. Calculate the field ratio (k) with Equation (3):

$$k = B_{RAD}/B_{TAN} \quad (3)$$

Where B_{RAD} and B_{TAN} are the maximum radial and tangential magnetic fields (see Figure 26).

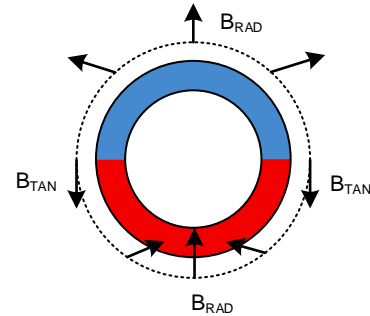

Figure 26: Side-Shaft Field

The k ratio depends on the magnet geometry and the distance to the sensor. If the k ratio does not equal 1, the sensor output response is nonlinear with respect to the mechanical angle. The error curve has the shape of a double sine wave, where E is the amplitude of this error (see Figure 27).

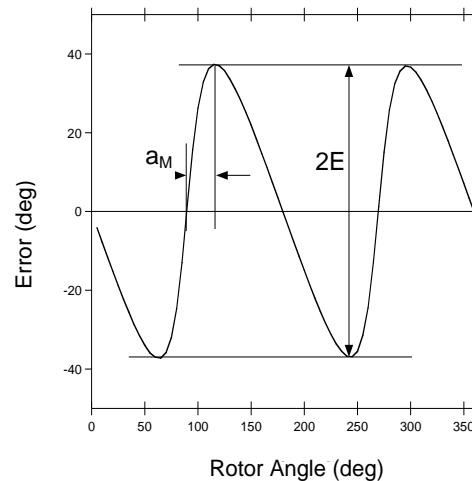

Figure 27: Error Curve in Side-Shaft Configuration (BCT = 0)

The X-axis or the Y-axis bias current can be reduced to recover an equal Hall signal for all angles and suppress the error. The parameters ETX and ETY control the direction in which sensitivity is reduced. The current reduction is set by the bias current trimming parameter (BCT[7:0]), which is an integer from 0 to 255.

In a side-shaft configuration (when the sensor's center is located beyond the magnet's outer diameter), the k ratio exceeds 1. If the value of k is known, BCT[7:0] can be calculated with Equation (4):

$$\text{BCT}[7:0] = 258 \left(1 - \frac{1}{k} \right) \quad (4)$$

For optimal compensation, the sensitivity of the radial axis should be reduced by setting the BCT parameter. Figure 28 shows the optimal BCT value for a particular k ratio.

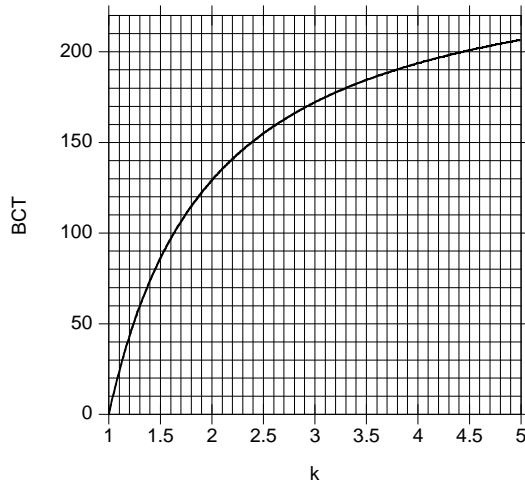

Figure 28: k Ratio and the Optimum BCT to Recover Linearity

Table 12 shows typical BCT values.

Table 12: Potential BCT Settings

E (deg)	Magnet Ratio (k)	BCT[7:0]
0	1.0	0
11.5	1.5	86
19.5	2.0	129
25.4	2.5	155
30.0	3.0	172
33.7	3.5	184
36.9	4.0	194
39.5	4.5	201
41.8	5.0	207

Determining k

The k ratio can be deduced from the error curve obtained with the default BCT setting (BCT = 0). Rotate the magnet more than one revolution and record the device's output. Next, plot the error curve (the output minus the real mechanical position vs. the real mechanical position) and extract two parameters: the maximum error (E), and the position of this maximum with respect to

a zero crossing (a_M) (see Figure 27). The k ratio can be calculated with Equation (5):

$$k = \frac{\tan(E + a_M)}{\tan(a_M)} \quad (5)$$

Alternatively, the value of k can be obtained using Figure 29.

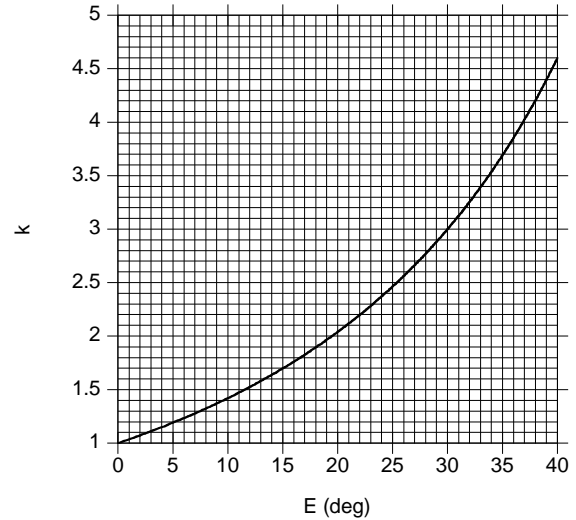

Figure 29: Relationship between the Error Measured with BCT = 0 and the Magnet Ratio k

Sensor Orientation

The dot marked on the package indicates whether the radial field is aligned with the sensor coordinate X or Y (see Figure 30).

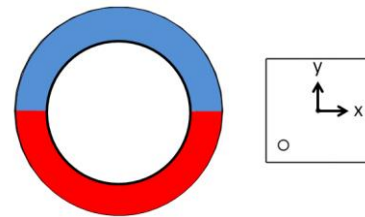

Figure 30: Package Top View with X- and Y-Axes

Determine which axis should be reduced based on the qualitative field distribution around a ring (see Figure 26 on page 20).

For example, Figure 30 shows that the field along the sensor's Y direction is tangential and weaker. This means that the X-axis should be reduced (ETX = 1 and ETY = 0).

If both ETX and ETY are set to 1, the current bias is reduced in both directions the same way (i.e. without side-shaft correction) (see Table 13).

Table 13: Trimming Direction Parameters

ETX	Enable Trimming of the X-Axis
0	Disabled
1	Enabled
ETY	Enable Trimming of the Y-Axis
0	Disabled
1	Enabled

Status Byte

Register 26 contains information about the sensor’s operational integrity.

ERRPAR

When using 17-bit communication on the SPI bus, the SPI write register command sent by the controller to the sensor can be checked for parity (unlike the other commands). The controller sends a parity bit on the MOSI line after the 16-bit command. The sensor checks the parity of the 17-bit long command. If there is a parity error, then the data to be written to the register is discarded and the ERRPAR bit asserts (set to 1).

ERRMEM

The ERRMEM bit asserts (set to 1) if an SPI write register command is sent while the NVM is busy (NVM pin is high). To avoid raising the ERRMEM flag, the user must ensure that no SPI write is sent while the NVM pin is high (set to 1). It is also recommended to check that the register value returned by the SPI write register command matches the desired written value (see the SPI Write Register section on page 14).

ERRNVM

Restoring register values from the NVM is secured by a cyclic redundancy check (CRC) algorithm. If the generated CRC result does not match the stored value (called a mismatch), the ERRNVM bit asserts (set to 1). If any error flag is asserted, the ERR pin is set to logic 1. Clear the error flags and ERR pin by sending the SPI Clear Error Flags command.

Filter Window Size

The filter window (FW) determines the effective resolution (defined as the $\pm 3\sigma$ noise interval). Figure 31 shows the effective resolution for different FWs and the magnetic field (B).

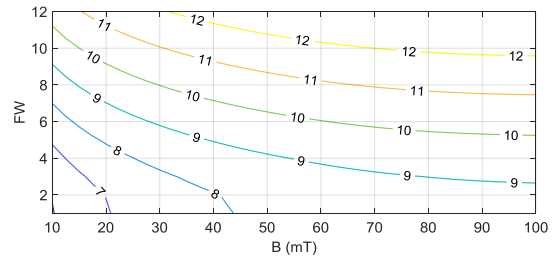
Figure 31: MA780 Resolution

Since FW modifies the filter time constant (τ), FW impacts the output bandwidth. The upper limit of the bandwidth and the cutoff frequency (f_{CUTOFF}) are related to τ . f_{CUTOFF} can be estimated with Equation (6):

$$f_{\text{CUTOFF}} = 0.16 / \tau \quad (6)$$

When the MA780 enters active mode (whether it is externally controlled or in ASC mode), the digital filter has to settle. Therefore, the angle output is not stable until a certain amount of time has passed (called the filter settling time). This time is indicated by the data valid flag (DV output pin). Table 14 show the time constant and the settling time for each window size.

Table 14: Filter Window Size ⁽⁹⁾

Filter Window FW[3:0]	τ (μs)	Filter Settling Time (μs)	f_{CUTOFF} (Hz)
0	1	1	160,000
1	2	3	79,600
2	4	7	39,800
3	8	15	19,890
4	16	31	9,950
5	32	63	4,970
6	64	127	2,490
7	128	255	1,240
8	256	511	622
9	512	1023	311
10	1024	2047	155
11	2048	4095	78
12	4096	8191	39
13	4096	8191	39
14	4096	8191	39
15	4096	8191	39

Note:

9) See the Electrical Characteristics section on page 4 for the filter settling time accuracy.

Latency

The latency is the difference between the true position of the mechanical angle and the angle reading that is available on the SPI interface. Latency is a function of the filter time constant (τ). Assuming the MA780 is in continuous active mode, the latency at a constant rotation speed is $\tau + 3\mu\text{s}$. In real applications, consider the latency. For a larger τ , the latency increases. If the latency is high, limit the rotation speed so that the angle error caused by latency is acceptable.

Low-Power Operation

Table 15 shows how to select the power modes. The ASCR bit determines if the ASC mode is controlled by the pin or the register.

Table 15: Power Modes Selection ⁽¹⁰⁾

EN (Pin)	ASC (Pin)	ASC (Reg.)	ASCR (Reg.)	Mode
0	0	x	0	Idle
0	1	x	0	ASC
0	x	0	1	Idle
0	x	1	1	ASC
1	x	x	x	Active

Note:

10) "x" means not applicable.

Table 16 shows examples of typical setting for mixed operation.

Table 16: Typical Setting for Mixed Operation

Mode	Pin for Switching	Preset Example
ASC only	None	EN = 0, ASCR = 1, ASC (reg.) = 1
Active to idle	EN	ASCR = 1 ASC (reg.) = 0
Active to ASC	EN	ASCR = 1 ASC (reg.) = 1
ASC to idle	ASC	EN = 0 ASCR = 0

Externally Switching Between Active Mode and Idle Mode

Pulling the EN pin high activates the MA780. After the filter settling time, the DV signal indicates that the measurement is stable. The master can send the MA780 back to idle mode while the angle remains in the MA780 output buffer, and the SPI interface remains active to allow data reading (see Figure 32).

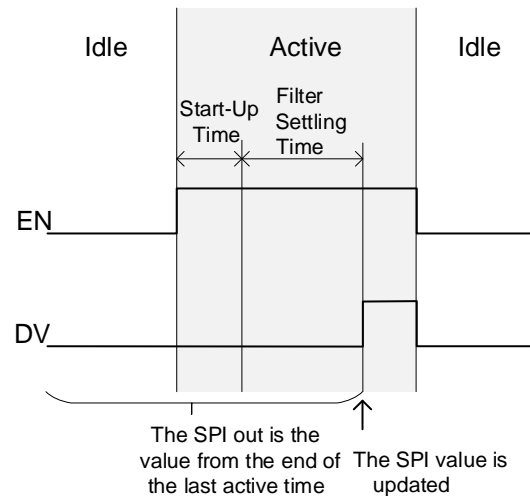

Figure 32: Signal Timing for External Control

Figure 33 shows the typical configuration to switch between active and idle mode.

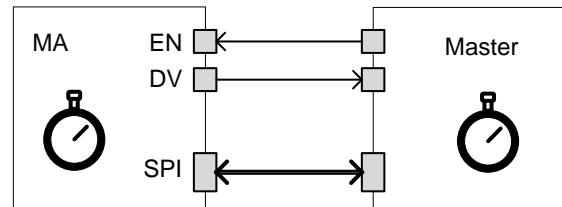

Figure 33: Typical Configuration for Switching Between Active and Idle Mode

Mixed Operation (Active Mode and ASC Mode)

It is possible to switch between a low-power ASC mode and a high-power active mode by driving the EN pin high or low, respectively. This allows for high-rate, full power measurements after certain angle changes are detected in ASC mode.

Mixed Operation (ASC Mode and Idle Mode)

When switching the MA780 between ASC and idle mode, drive the ASC state using the ASC pin or register. ASC mode is activated when ASC is high. In this configuration, the angle is updated when the device is in ASC mode (see Figure 34).

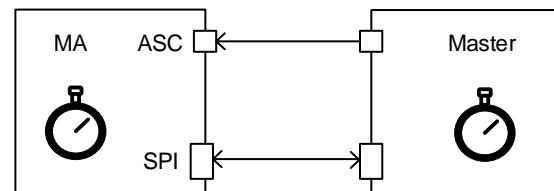

Figure 34: Typical Configuration to Switch between ASC and Idle Mode using the ASC Pin

Configurations for ASC Mode

The power cycles are defined by the active time and the cycle time. By default (AUTACT = 1), the active time is automatically adjusted to the filter window, such that the active time ends when the filter has settled. The active time (t_{ACTIVE}) can be calculated with Equation (7):

$$t_{ACTIVE} = t_{START-UP} + t_{SETTLING} \quad (7)$$

Where $t_{SETTLING}$ can be determined by Table 14 on page 22. ASC mode is recommended for most applications. Figure 35 shows the timing for an ASC cycle.

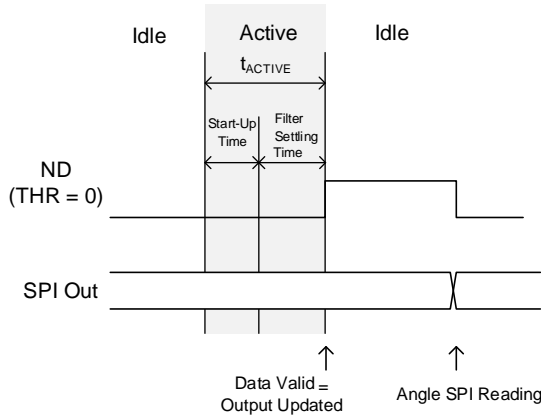

Figure 35: Timing of a ASC Cycle when THR = 0 and AUTACT = 1

If AUTACT is disabled, the active time is defined by the TACT parameter. The active time ranges between 40µs and 2056µs, with 8µs per step (see Table 17).

Table 17: Active Time

TACT[7:0]	t_{ACTIVE} (µs)
0	Do not use
1	Do not use
2	Do not use
3	40
4	48
5	56
...	...
255	2056

If TACT[7:0] exceeds 2, t_{ACTIVE} (in µs) can be calculated with Equation (8):

$$t_{ACTIVE} (\mu s) = 8 \times TACT[7:0] + 16 \quad (8)$$

Table 17 lists potential times for t_{ACTIVE} (see the Electrical Characteristics on page 4 for active time accuracy).

The active time should be set such that the angle output is stable (the filter has settled and the data is valid). This means the active time should exceed the valid data time. t_{ACTIVE} can be estimated with Equation (9):

$$t_{ACTIVE} > t_{START-UP} + t_{SETTLING} \quad (9)$$

Figure 36 shows the timing of an ASC cycle.

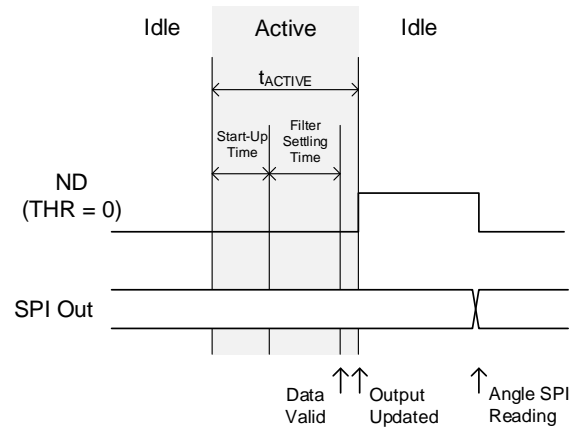

Figure 36: Timing of an ASC Cycle when THR = 0 AUTACT = 0

Cycle Time

The ASC cycle time is set by the TCYC parameter. TCYC can be directly configured by the user. The cycle time must be longer than the active time (see Table 18). Otherwise, the cycle time increases by an integer number of times until it is longer than t_{ACTIVE} .

Table 18: Cycle Time

TCYC	Cycle Time (ms)
0	Continuously idle
1	Do not use
2	0.2
3	0.3
4	0.4
...	...
65535	6553.5

See the Electrical Characteristics section on page 4 for the cycle time accuracy.

Once the TACT and TCYC parameters are set, the average current consumption can be calculated with Equation (10):

$$I_{AVERAGE} = I_{ACTIVE} \times \frac{t_{ACTIVE}}{t_{CYCLE}} + I_{IDLE} \times (1 - \frac{t_{ACTIVE}}{t_{CYCLE}}) \quad (10)$$

New Data (ND) Pin

The new data (ND) signal has different use cases, depending on the value of the threshold parameter (THR). If THR = 0, this indicates the end of an active period. The ND signal rises after each active phase ends, and latches to indicate that a new value is available in the output buffer (see Figure 37).

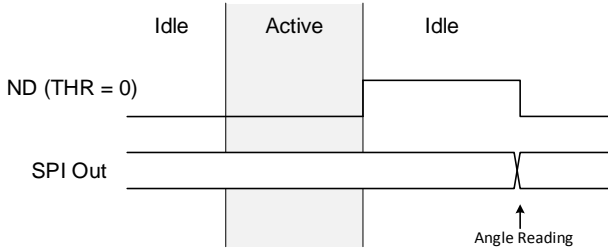

Figure 37: Using the ND Pin as a Flag for Data Updates (THR = 0)

If THR > 0, the device detects an angle change, and the ND pin becomes a warning-on-change (WOC) signal (see Figure 39). The reference value used to detect a change can either be a fixed value, or it can be configured by the user at each WOC via register 10.

The ND flag is reset on the first SCLK rising edge of the following actions/commands:

- Read angle
- Store registers to NVM
- Restore registers from NVM
- Clear status byte

Note that the ND flag cannot be reset with a read ID command, or by writing or reading the registers.

If the active time is shorter than the filter settling time (determined by TACT and FW[3:0]), the ND signal is not updated. This is because the output angle value is not fully stabilized, so the output angle is not within the required resolution (DV, the data valid signal, has not been set to logic high).

Figure 37 shows the timing diagram of the ND pin when THR = 0. Figure 38 shows when the ND signal requests a simple connection.

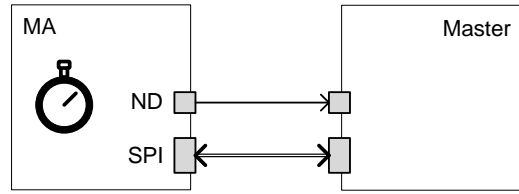

Figure 38: Reading Both the SPI and ND

With a non-zero threshold, the ND signal does not systematically rise after each new value. ND only rises when the angle exceeds the threshold (see Figure 39).

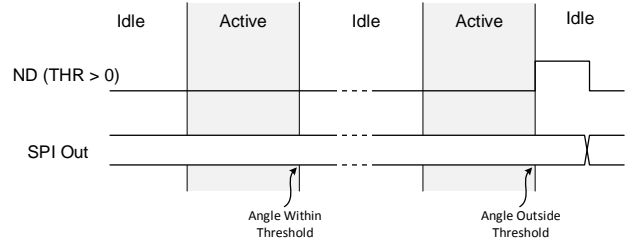

Figure 39: Using the ND Pin as a WOC Signal with a Non-Zero Threshold Setting.

If the angle exceeds the threshold in ASC mode, the ND signal asserts high after every active sample period (see Figure 40). In Figure 40, vertical lines indicate the end of the active period, while arrows indicate SPI readings.

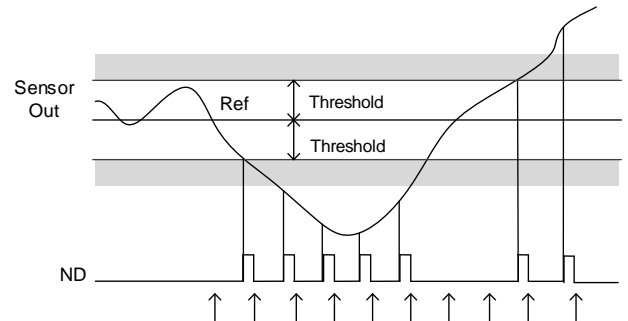

Figure 40: Example of ND Signal when the Angle is Changing in ASC Mode

Threshold (THR)

The THR parameter is a relative angle coded on 8 bits (see Table 19). If THR exceeds 180°, the ND flag is disabled.

Table 19: Threshold to Wake Up

THR[6:0]	Threshold (degrees)
0	0
1	1.41
2	2.81
...	...
127	178.59
128	180 (ND flag only at 180°)
129	181.41 (no ND flag)
...	...
255	358.59 (no ND flag)

Reference (REF)

The angle change is defined in relationship to a reference angle. REF is a parameter that controls this angle. The ND pin goes high when the angle distance to REF exceeds the threshold.

REF is an absolute angle coded on 8 bits (see Table 20).

Table 20: Change Detection Fixed Reference

REF[7:0]	Reference (deg)
0	0
1	1.41
2	2.81
...	...
255	358.59

To detect the relative motion and avoid repeatedly asserting the ND signal when the angle is outside the set threshold, update the reference position (REF) in register 10 with the current angle position each time the threshold is crossed.

Turn Counting

The MA780 can count 16, 64, and 256 rotation turns. The counter value is coded on M = 4, 6, or 8 bits by the MULT parameter (see Table 21). The number of turns is indicated by the M bits on the MSB side of the 16-bit output. As a consequence, the angle information is shifted by M bits, and the resolution is reduced by M bits, as seen below:

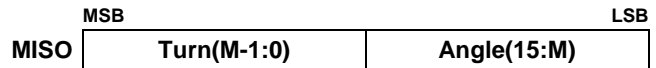

The number of turns to count is set by MULTI[1:0], and the value is stored in register 22. When writing to this register, only modify bit[3] and bit[4], and ensure that the other bits retain their default value (see Table 8 on page 18).

Table 21: Turn Counting

MULTI[1:0]	Number of Turns	M (Bit Used to Count Turns)
0	0 (default)	0
1	16	4
2	64	6
3	256	8

The counter value is stored in the volatile memory. When the MA780 is idle, the value is maintained until the next angle update. When updating the turn count, the sensor always assumes that the angle increment is smaller than 180 degrees. This means that if the shaft turns more than 180 degrees per idle time, the counter goes backwards.

To prevent turn count errors, ensure that the angle change during the idle time is always below 180 degrees. When counting up, the counter overflows back to zero after reaching its maximum value for the specified number of bits (M). A similar principle applies when counting down from zero to the maximum value.

If power is removed from the sensor, the counter always resets to zero. In normal operation, the zero setting only affects the angle. The angle does not reset the turn counter.

TYPICAL APPLICATION CIRCUIT

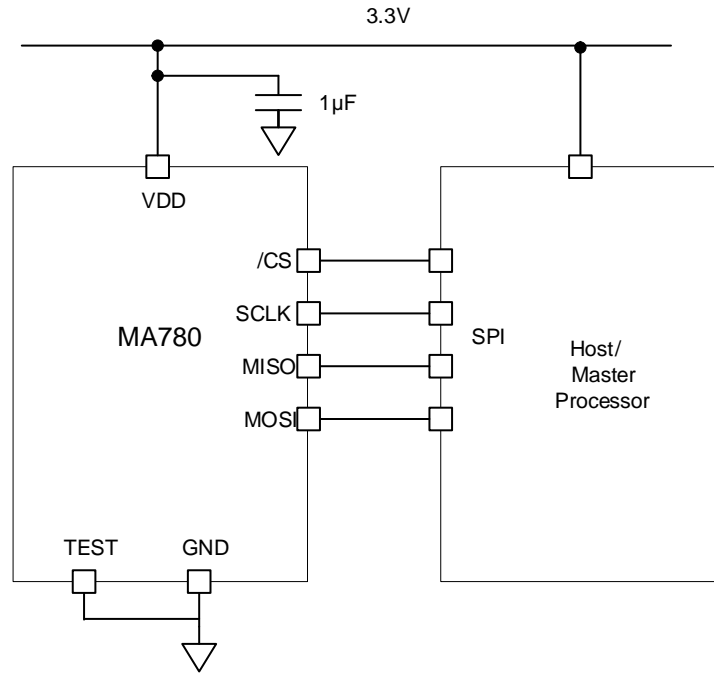
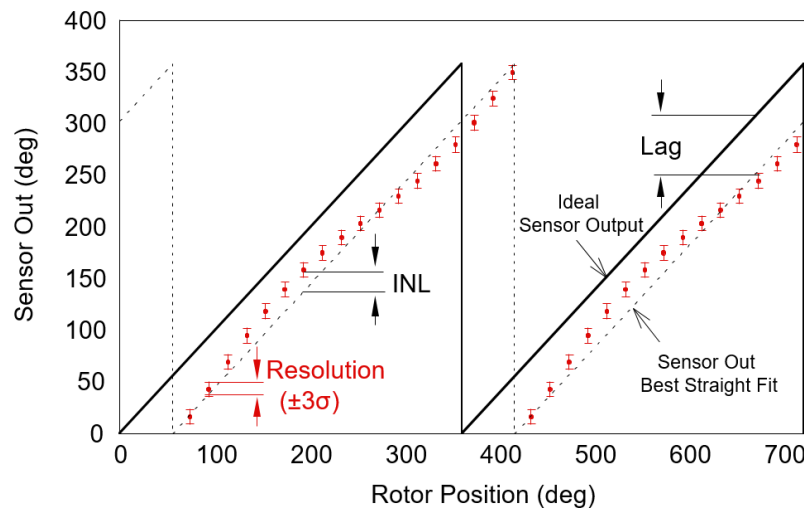

Figure 41: Typical Application Circuit Using the SPI Interface

APPENDIX A: DEFINITIONS

Effective Resolution (3σ Noise Level)	Smallest angle increment distinguishable from the noise. The resolution is measured by computing three times σ (the standard deviation in degrees) taken over 1,000 data points at a constant position. The bit resolution is calculated as: $\log_2(360 / 6\sigma)$.
Refresh Rate	Rate at which new data points are stored in the output buffer.
Latency	The time elapsed between the instant when the data is ready to be read and the instant at which the shaft passes that position. The lag in degrees is $\text{lag} = \text{latency} \times v$, where v is the angular velocity (in deg/s).
Power-Up Time	Time until the sensor delivers valid data beginning at start-up ($V_{DD} < 3V$).
Start-Up Time	Time until the sensor front end delivers valid data to the digital treatment block when recovering from idle mode.
Filter Settling Time	Time for the filter to deliver a stable angle (i.e. when the error is smaller than the noise at the particular filter window setting).
Integral Nonlinearity (INL)	Maximum deviation between the average sensor output (at a fixed position) and the true mechanical angle (see Figure A1).

Figure A1: Resolution, INL, Lag

INL can be obtained from the error curve $\text{err}(a) = \text{out}(a) - a$, where $\text{out}(a)$ is the average output across 1000 sensor outputs, and a is the mechanical angle indicated by a high precision encoder (<0.001 deg). INL can be calculated with Equation (A1):

$$\text{INL} = \frac{\max(\text{err}(a)) - \min(\text{err}(a))}{2} \quad (\text{A1})$$

Drift

The angle variation rate when one parameter is changed (e.g. temperature, V_{DD}) while all the others, such as the shaft angle, remain constant.

APPENDIX B: SPI COMMUNICATION CHEATSHEET

Read Angle (see the SPI Read Angle section)

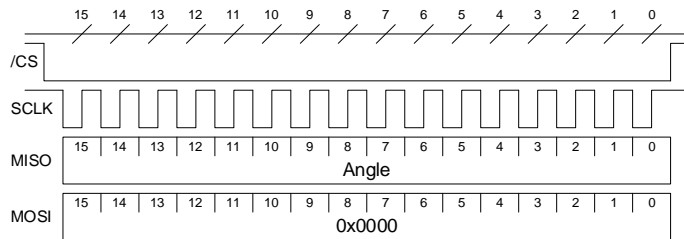

Read Register (see the SPI Read Register section)

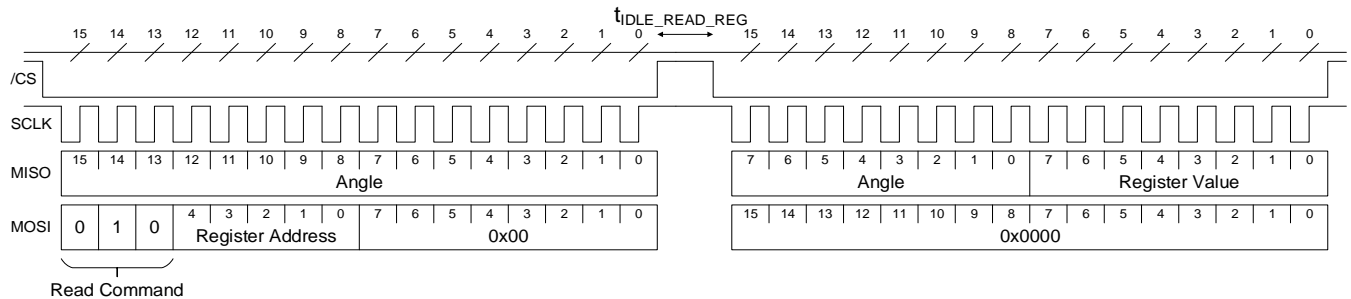

Write Register (see the SPI Write Register section)

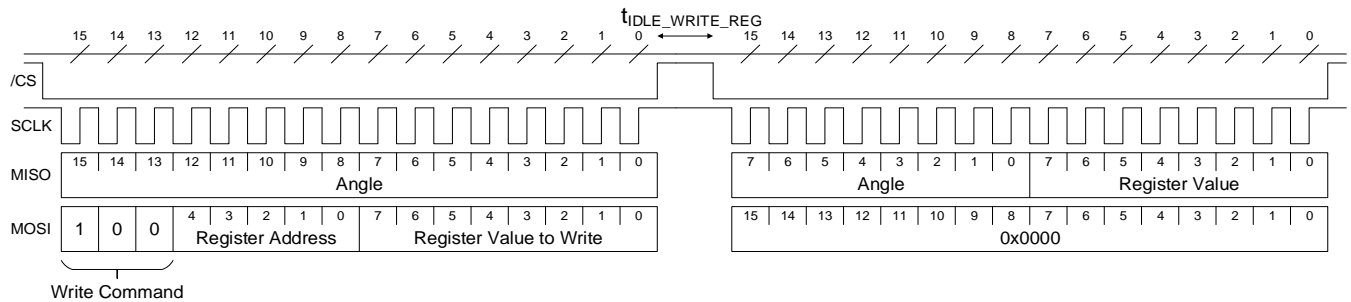

Store a Single Register Value to NVM (see the SPI Store a Single Register to NVM section)

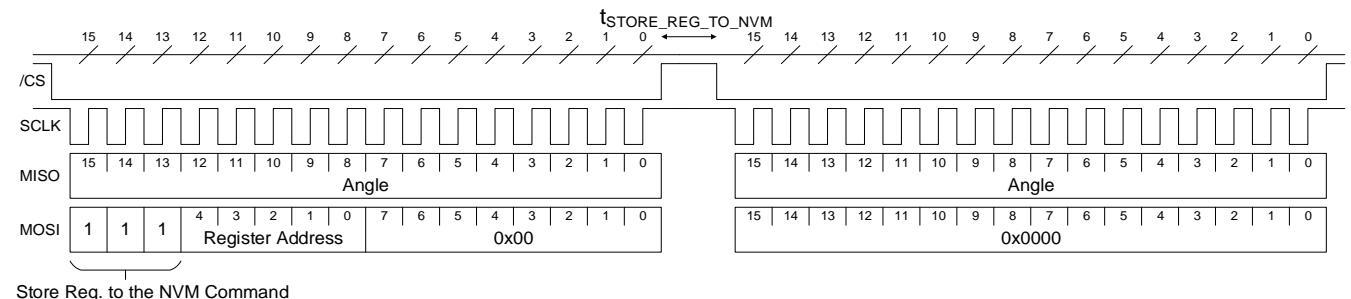

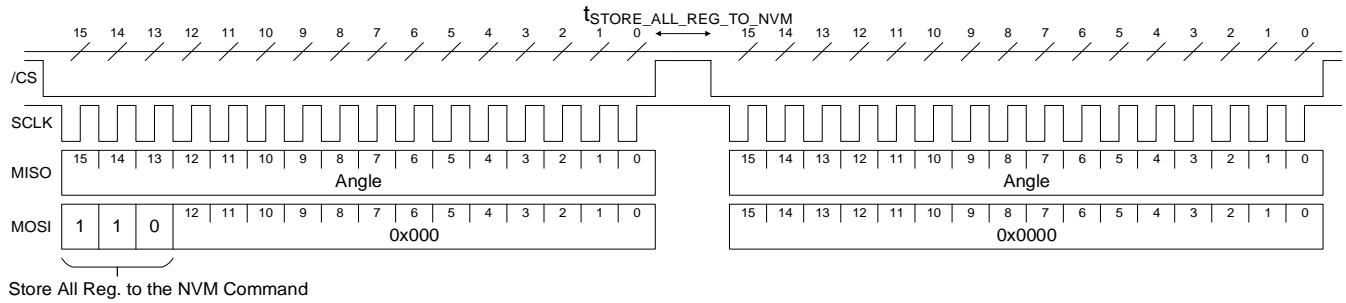
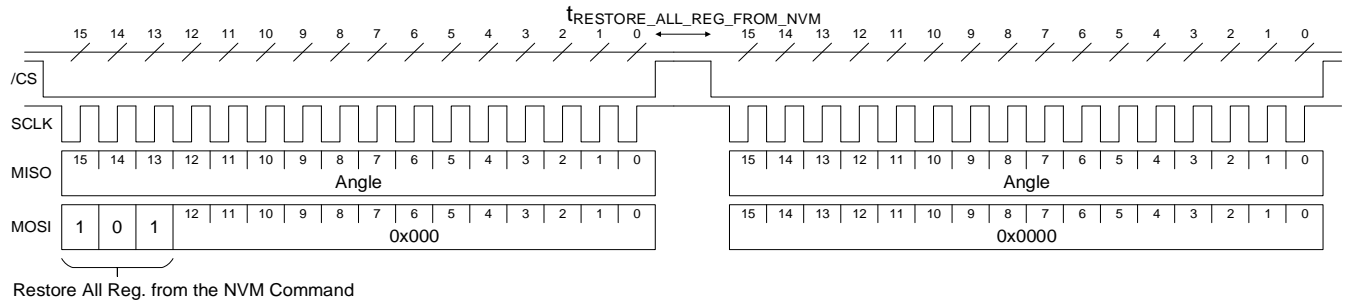
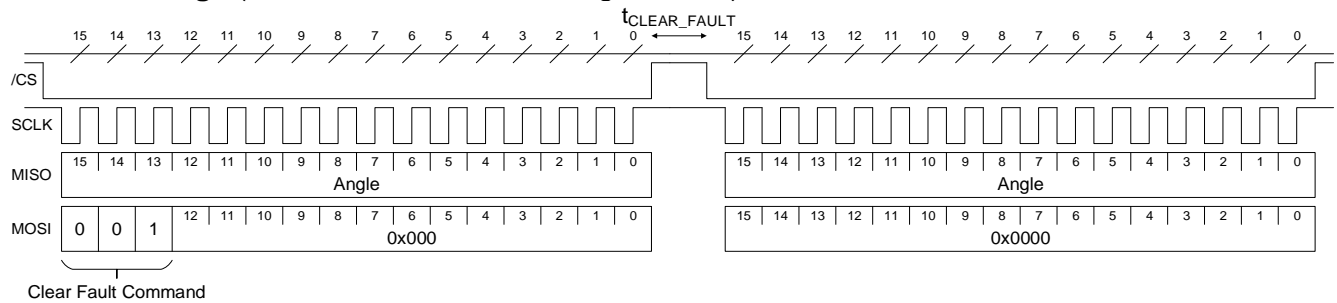
Store All Register Values to NVM (see the SPI Store All Registers to NVM section)

Restore All Register Values from NVM (see the SPI Restore All Registers from NVM section)

Clear Error Flags (see the SPI Clear Error Flags section)

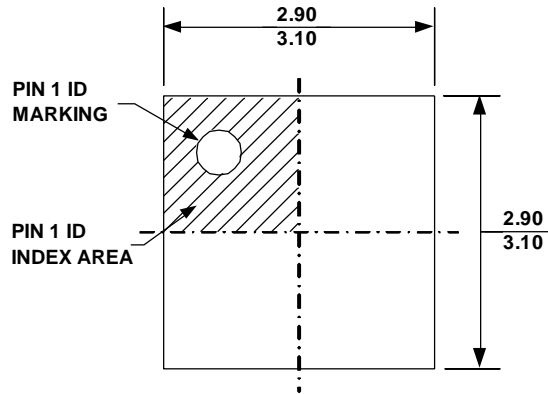
PACKAGE INFORMATION

QFN-16 (3mmx3mm)

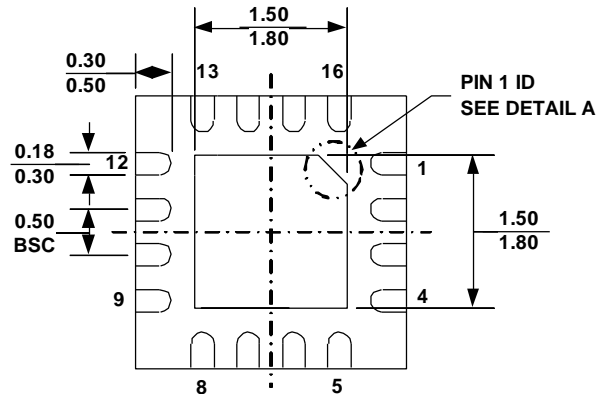

TOP VIEW



BOTTOM VIEW

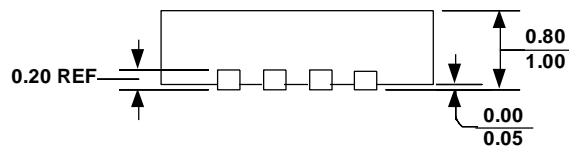

SIDE VIEW

PIN 1 ID OPTION A
0.30x45° TYP.

PIN 1 ID OPTION B
R0.20 TYP.

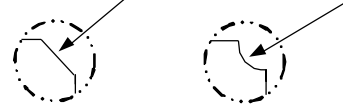

DETAIL A

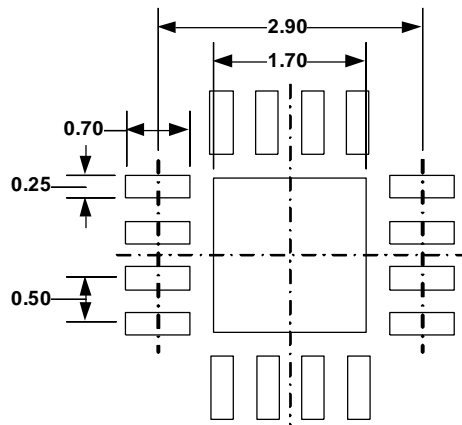

RECOMMENDED LAND PATTERN

NOTE:

- 1) ALL DIMENSIONS ARE IN MILLIMETERS.
- 2) EXPOSED PADDLE SIZE DOES NOT INCLUDE MOLD FLASH.
- 3) LEAD COPLANARITY SHALL BE 0.10 MILLIMETER MAX.
- 4) DRAWING CONFORMS TO JEDEC MO-220, VARIATION VEED-4.
- 5) DRAWING IS NOT TO SCALE.

CARRIER INFORMATION

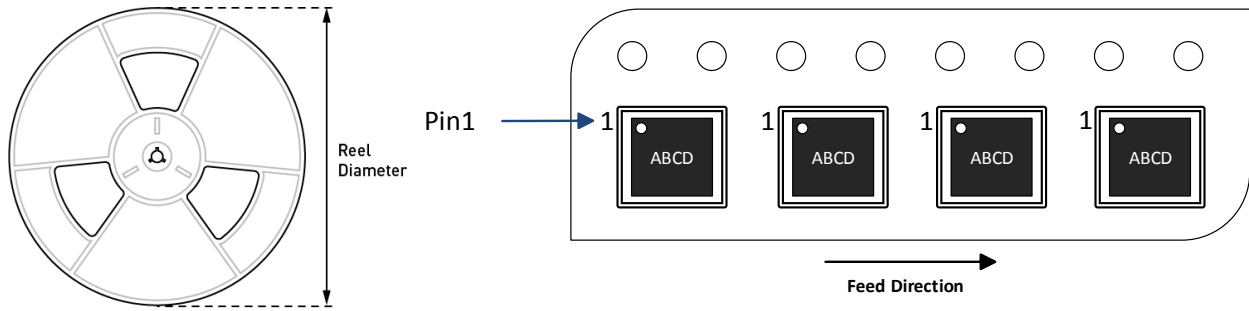

Part Number	Package Description	Quantity/Reel	Reel Diameter	Carrier Tape Width	Carrier Tape Pitch
MA780GQ-Z	QFN-16 (3mmx3mm)	5000	13in	12mm	8mm

REVISION HISTORY

Revision #	Revision Date	Description	Pages Updated
1.0	04/30/2020	Initial Release	-
1.1	6/18/2021	Updated Electrical Characteristics section	4
		Updated the Low-Power Operation section	23
		Grammar and formatting updates	All
1.2	8/30/2021	Updated the Electrical Characteristics section	4
		Updated the Table 16 values	23
		Grammar and formatting updates; updated headers for consistency; updated footnote numbers	All

Notice: The information in this document is subject to change without notice. Please contact MPS for current specifications. Users should warrant and guarantee that third-party Intellectual Property rights are not infringed upon when integrating MPS products into any application. MPS will not assume any legal responsibility for any said applications.