

DIODE Type : 20KDA10

2A 100V Tj =150 °C

OUTLINE DRAWING

FEATURES

- * Miniature Size
- * Low Forward Voltage drop
- * Low Reverse Leakage Current
- * High Surge Capability
- * 52mm Inside Tape Spacing Package Available

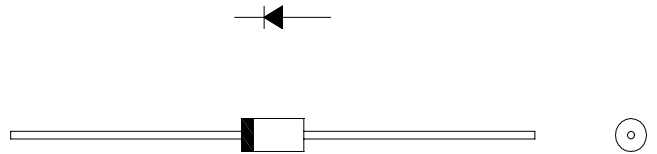

Maximum Ratings

Approx Net Weight:0.38g

Rating	Symbol	20KDA10		Unit
Repetitive Peak Reverse Voltage	V_{RRM}	100		V
Average Rectified Output Current	I_O	50Hz Half Sine Wave Resistive Load	Ta=34°C *1 1.7	A
			Tl=115°C (Tl: Lead Temperature) 2.0	
RMS Forward Current	$I_{F(RMS)}$	3.14		A
Surge Forward Current	I_{FSM}	50Hz Half Sine Wave,1cycle, Non-repetitive		75 A
Operating JunctionTemperature Range	T_{jw}	- 40 to + 150		°C
Storage Temperature Range	T_{stg}	- 40 to + 150		°C

Electrical • Thermal Characteristics

Characteristics	Symbol	Conditions	Min.	Typ.	Max.	Unit
Peak Reverse Current	I_{RM}	Tj= 25°C, $V_{RM}= V_{RRM}$	-	-	10	μA
Peak Forward Voltage	V_{FM}	Tj= 25°C, $I_{FM}= 2.0A$	-	-	1.0	V
Thermal Resistance	Rth(j-a)	Junction to Ambient *1	-	-	70	°C/W
	Rth(j-l)	Junction to Lead	-	-	17	

*1: Without Fin or P.C. Board mounted (L=8mm, Print Land=15 x 15mm, Both Sides)

20KDA OUTLINE DRAWING (Dimensions in mm)

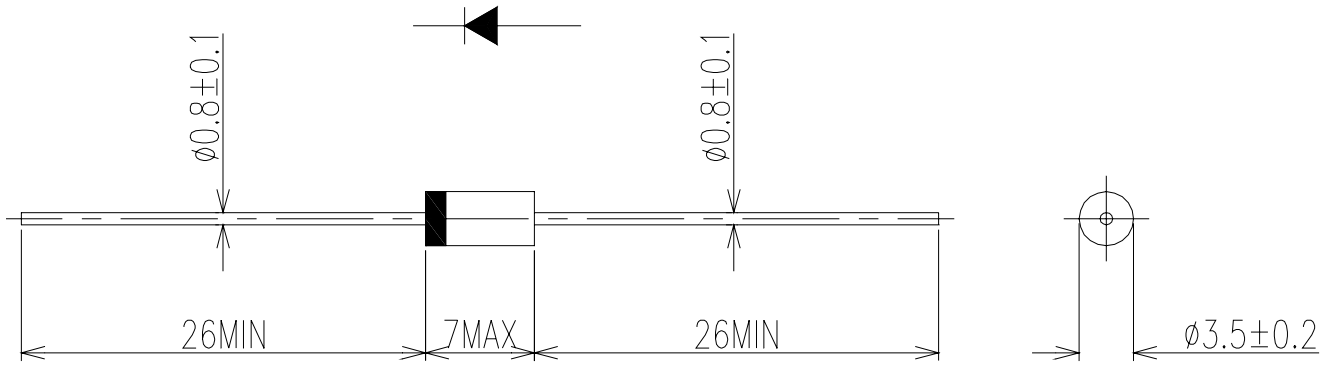

FORWARD CURRENT VS. VOLTAGE

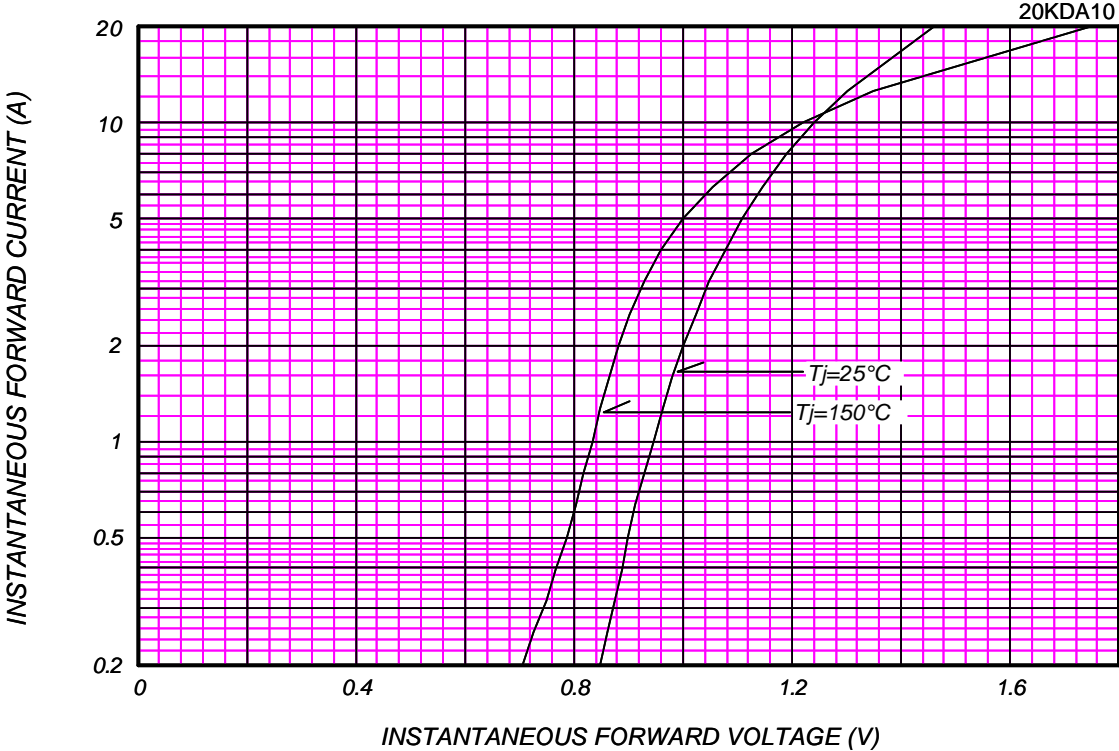

AVERAGE FORWARD POWER DISSIPATION

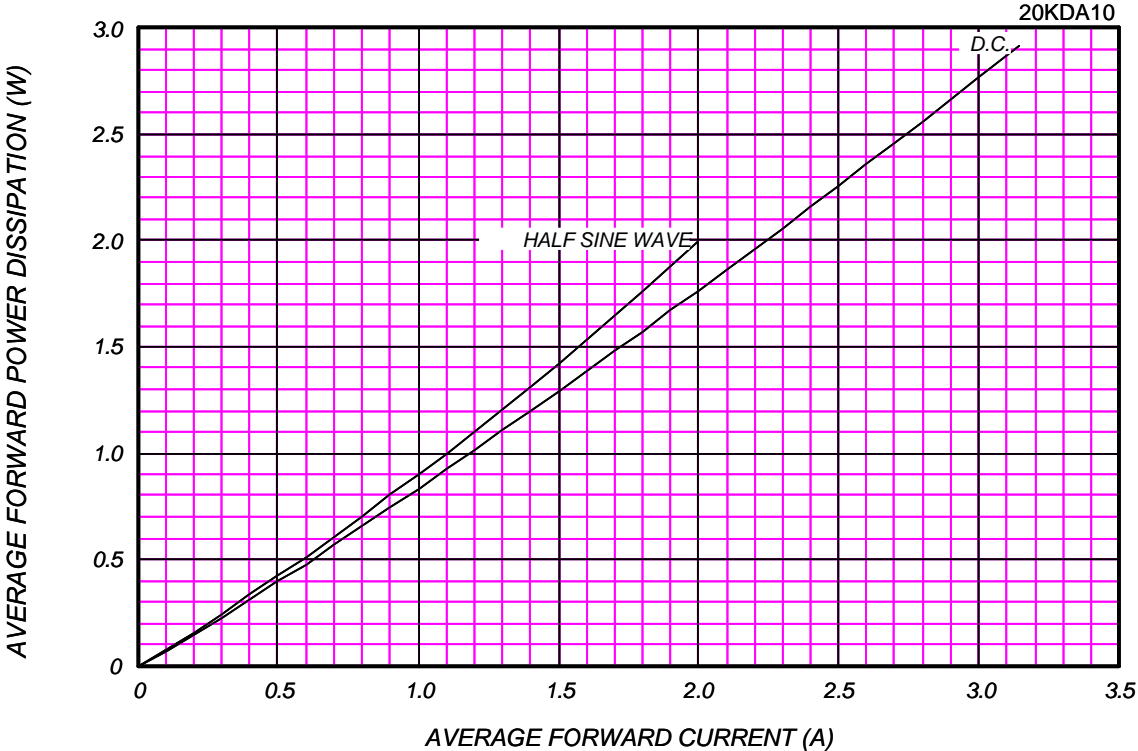

AVERAGE FORWARD CURRENT VS. AMBIENT TEMPERATURE

P.C. Board mounted (L=8mm,Print Land=15x15mm,Both Sides)

20KDA10

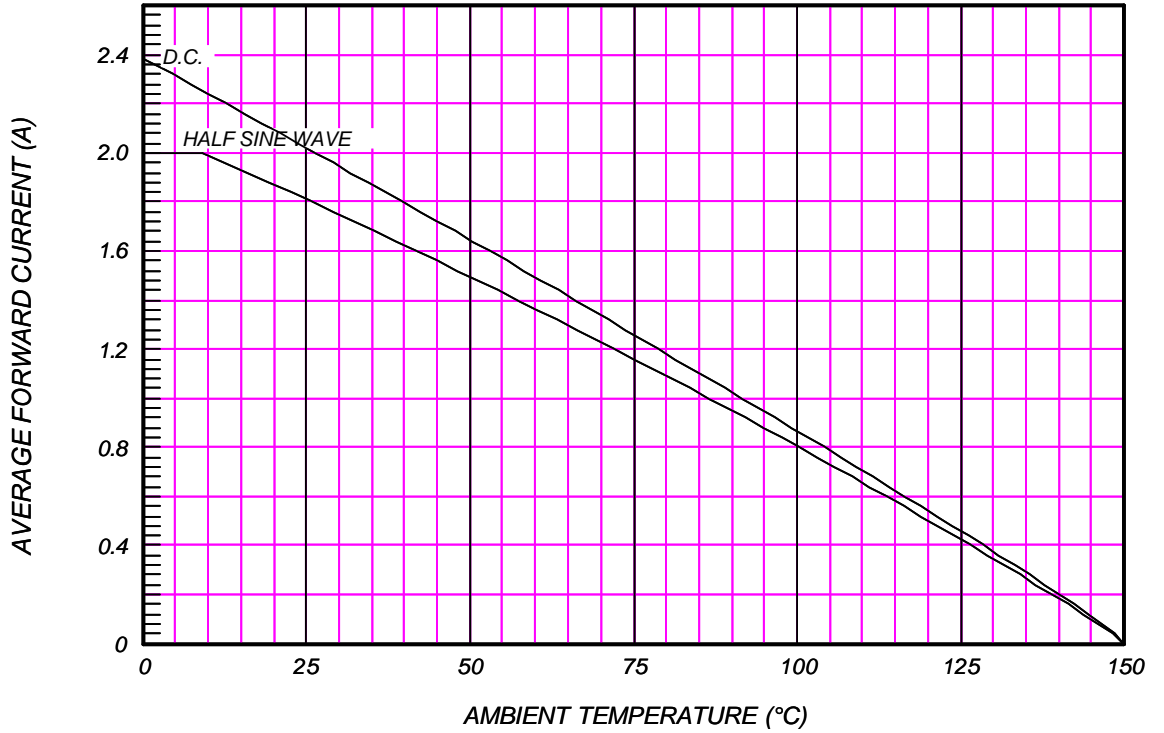

AVERAGE FORWARD CURRENT VS. LEAD TEMPERATURE

($R_{th(j-l)}=17C/W$)

20KDA10

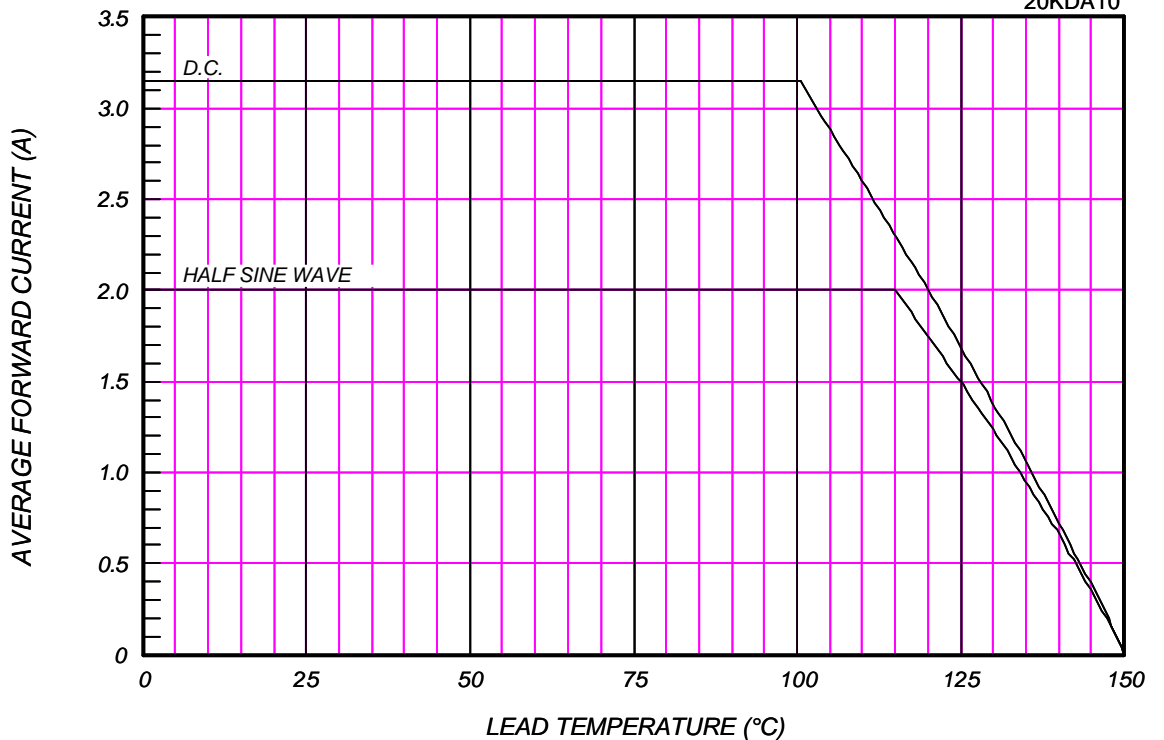

SURGE CURRENT RATINGS

f=50Hz, Half Sine Wave, Non-Repetitive, No Load

20KDA10

