

Versatile Reader/Writer Reliably Handles
Read Function for Magnetic Cards or
Read/Write Function for IC Cards

- Compact size and light weight allow easy installation in any terminal
- Single and triple track capability
- Heavy-duty construction for secure environments
- High speed card transport
- Shutter available to prevent insertion of foreign objects and improper cards



Ordering Information

Magnetic Tracks Supported (R, R/W)					IC Contact	Interface	Built-in Shutter	Cover/ Cable	Card Ejection	Color	Part Number
1	2	3	Center	JIS II							
R	R	R	—	—	No	TTL	No	No	Front/Rear	Black	3S4YR-MCR1-N-02
R	R	R	—	—	No	TTL	Yes	No	Front/Rear	Black	3S4YR-MCR1D-N-02
—	R	—	—	—	No	TTL	No	No	Front/Rear	Black	3S4YR-MCR4-N-02
—	R	—	—	—	No	TTL	Yes	No	Front/Rear	Black	3S4YR-MCR4D-N-02
—	—	—	—	—	ISO 7816/CP8*	TTL	Yes	No	Front	Black	3S4YR-MCR0XD
—	—	—	—	—	ISO 7816/CP8**	TTL	No	No	Front/Rear	Black	3S4YR-MCR0XCB
—	—	—	—	—	ISO 7816/CP8**	TTL	Yes	No	Front/Rear	Black	3S4YR-MCR0XDB

Note: Consult the *IC Card Basics* section of this catalog for IC contact descriptions.

* Friction IC contact

** Landing IC contact

■ ACCESSORIES

Description	Part Number
Shutter for MCR (Prevents tampering and incorrect card insertion)	SHUTTER FOR MCR

■ TYPICAL APPLICATIONS

- ID Card Checkers
- Access Control
- Automatic Gate Machines
- EFT
- POS
- Vending Machines
- Kiosks

Specifications

Part number		3S4YR-MCR				
Recommended card type	Magnetic card	ISO 7810, 7811/1-5, 7812, 7813				
	IC Card	ISO 7816/1-2				
Recording method		FM decoding (F2F)				
Card feeding speed		40 cm/sec (15.7 in/sec)				
Motor type		DC motor				
Service life (See note)	Magnetic head	1,000,000 passes				
	IC contact	300,000 times with rear ejection; 100,000 times without rear ejection				
	Transport roller	1,000,000 passes or 5 years				
	Drive belt	1,000,000 passes or 5 years				
	Entire unit	1,000,000 passes (excluding the above mentioned parts)				
Operating power supply		24 VDC ± 10%				
Max. current consumption	MCR□	-N-02	D-N-02	XD	XCB	XDB
	Waiting	25 mA	30 mA	10 mA	20 mA	25 mA
	Operating	350 mA	550 mA	350 mA	500 mA	700 mA
	Start-up, reverse	2A	2A	2A	2A	2A
Mounting location		Indoors — away from wind, rain, and sunlight				
Ambient temperature	Operation	-5° to 55°C (23° to 131°F)				
	Storage	-25° to 70°C (-13° to 158°F)				
Ambient humidity	Operation	45% to 85% RH without condensation				
	Storage	20% to 90% RH				
Vibration (when not in use)		Single amplitude: 0.75 mm Max acceleration: 100 mm/sec ² ; 10 to 150 Hz for 30 minutes in X, Y, and Z directions				
Shock (when not in use)		300 m/sec ² (30 G) three times in each of X, Y, and Z directions				
Dimensions	MCR□	-N-02	D-N-02	XD	XCB	XDB
	Length	122 mm (4.80 in)	147 mm (5.79 in)	147 mm (5.79 in)	122 mm (4.80 in)	147 mm (5.79 in)
	Width	90 mm (3.54 in)	90 mm (3.54 in)	105 mm (4.13 in)	90 mm (3.54 in)	105 mm (4.13 in)
	Height	62 mm (2.44 in)	62 mm (2.44 in)	62 mm (2.44 in)	95 mm (3.74 in)	95 mm (3.74 in)
Weight	MCR□	-N	D-N	XD	XCB	XDB
		550 g (19.4 oz)	750g (26.5 oz)	800 g (28.2 oz)	900 g (31.7 oz)	1,100 g (38.8 oz)

Note: One pass denotes one-way travel of card feed.

Engineering Data

OUTPUT CIRCUIT DIAGRAM

Input Circuit

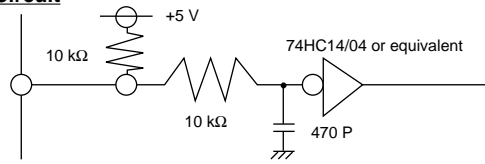

I/F Board

Output Circuit, cont.

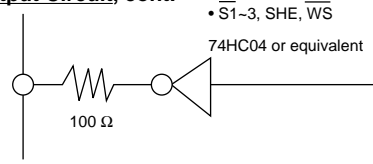

I/F Board

Output Circuit

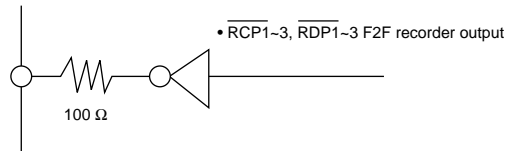

I/F Board

$I_{OH} = -1 \text{ mA MAX (} V_{OH} = 3.5 \text{ V MIN)}$
 $I_{OL} = 4 \text{ mA MAX (} V_{OL} = 0.4 \text{ V MAX)}$

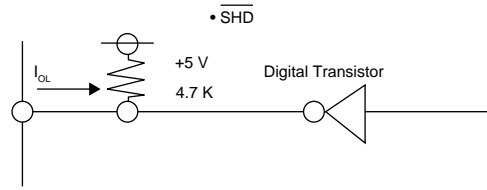

I/F Board

$I_{OL} = 10 \text{ mA MAX (} V_{OL} = 0.4 \text{ V MAX)}$

I/O INFORMATION

3S4YR-MCRN 1/1D/3/3D/4/4D/5/5D-02

Card reader side: Hirose Electric HIF3BA-26PA-2, 54DS (male)
 Cable side: Connector socket conforming to MIL-C-83503 (female);
 Berg 66900-266 or 65846-002; 3M 3399-6500SC+3448-3926J
 (connector + strain relief, cable-side connector is not included).

Pin #	Signal	Input/Output	Description
1	24V	—	24 VDC
2	24V	—	24 VDC
3	POV	—	0 VDC
4	POV	—	0 VDC
5	$\overline{\text{MFS}}$	Input	Motor forward signal
6	$\overline{\text{MRS}}$	Input	Motor reverse signal
7	$\overline{\text{S1}}$	Output	Card location sensor 1
8	$\overline{\text{S2}}$	Output	Card location sensor 2
9	$\overline{\text{S3}}$	Output	Card location sensor 3
10	—	—	—
11	$\overline{\text{RDP1}}$	Output	Read data, track 1
12	$\overline{\text{RCP1}}$	Output	Read clock, track 1
13	$\overline{\text{RDP2}}^*$	Output	Read data, track 2
14	$\overline{\text{RCP2}}^*$	Output	Read clock, track 2
15	$\overline{\text{RDP3}}^*$	Output	Read data, track 3
16	$\overline{\text{RCP3}}^*$	Output	Read data, track 3
17	—	—	—
18	—	—	—
19	—	—	—
20	—	—	—
21	$\overline{\text{WS}}^{**}$	Output	Card width switch
22	$\overline{\text{SHD}}^{**}$	Output	Sense head detector
23	$\overline{\text{SO}}^{**}$	Input	Shutter open/close
24	$\overline{\text{SHE}}^{**}$	Output	Shutter echo switch
25	—	—	—
26	0 VDC	—	0 VDC (GND)

3S4YR-MCR0X CB/D/DB

Card reader side: Hirose Electric HIF3BA-26PA-2, 54DS (male)
 Cable side: Connector socket conforming to MIL-C-83503 (female);
 Berg 66900-226 or 65846-002; 3M 3399-6500SC+3448+3026J
 (connector + strain relief, cable-side connector is not included).

Pin #	Signal	Input/Output	Description
1	24V	—	24 VDC
2	24V	—	24 VDC
3	POV	—	0 VDC
4	POV	—	0 VDC
5	$\overline{\text{MFS}}$	Input	Motor forward signal
6	$\overline{\text{MRS}}$	Input	Motor reverse signal
7	$\overline{\text{S1}}$	Output	Card location sensor 1
8	$\overline{\text{S2}}$	Output	Card location sensor 2
9	$\overline{\text{S3}}$	Output	Card location sensor 3
10	IVCC	◆	IC card VCC
11	IRST	◆	IC card RESET
12	ICIO	◆	IC card IN/OUT
13	IGND	◆	IC card GND
14	ICLX	◆	IC card PROGRAM
15	IVVP	◆	IC card CLOCK
16	IRS1	◆	IC card RESERVE 1
17	IRS2	◆	IC card RESERVE 2
18	$\overline{\text{IECO}}^{***}$	Output	IC card contact press echo
19	$\overline{\text{IECS}}^{***}$	Output	Stopper release sensor echo (rear ejection only)
20	$\overline{\text{ISO1}}^{***}$	Input	IC card contact press
21	$\overline{\text{WS}}^{**}$	Output	Card width switch
22	$\overline{\text{SHD}}^{**}$	Output	Sense head detector
23	$\overline{\text{SO}}^{**}$	Input	Shutter open/close
24	$\overline{\text{SHE}}^{**}$	Output	Shutter echo switch
25	$\overline{\text{ISO2}}^{***}$	Input	IC card stopper release (rear ejection only)
26	0 VDC	—	0 VDC (GND)

* Signals applicable for the MCR1-N and MCR1D-N only.

** Signals applicable when shutter is attached.

*** Signals applicable for rear ejection models only.

◆ = Direct IC Contact

Dimensions

Unit: mm (inch)

■ 3S4YR-MCRN-02

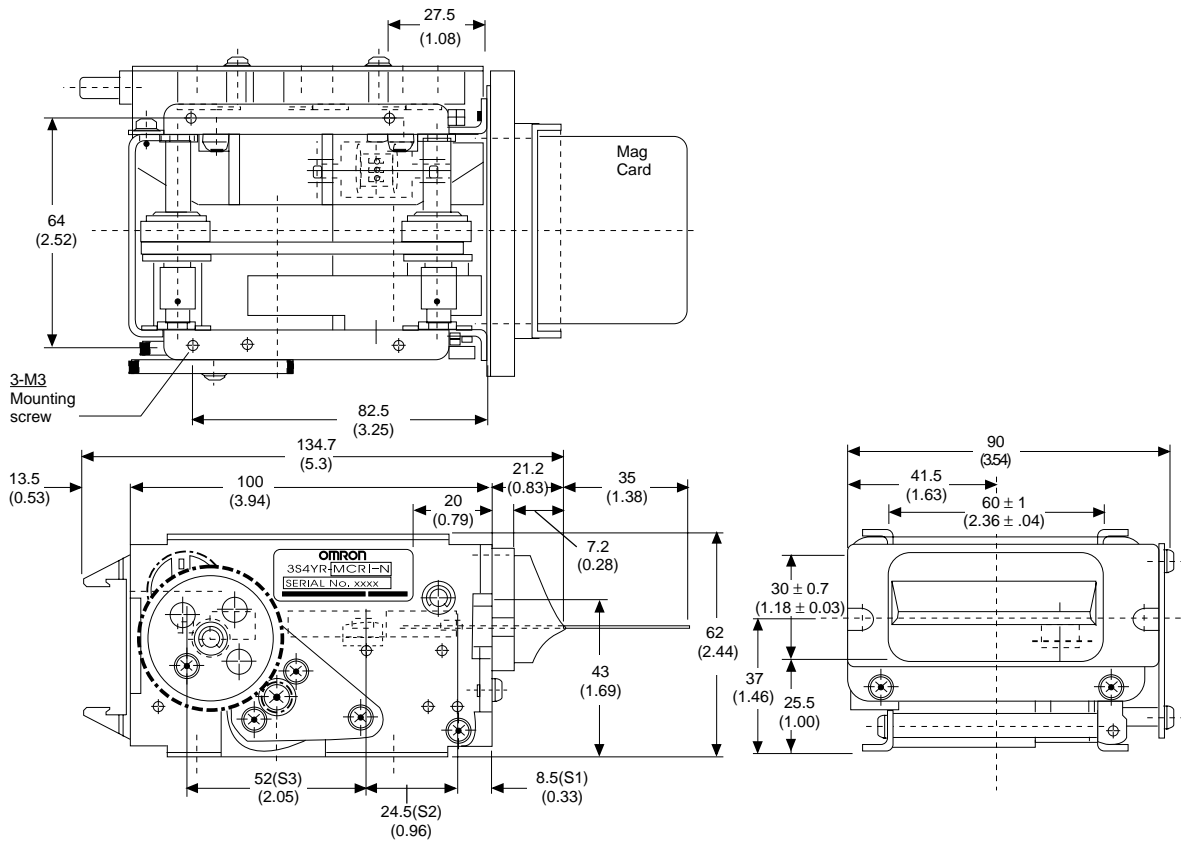

■ 3S4YR-MCR0XDB (Landing IC Contact)

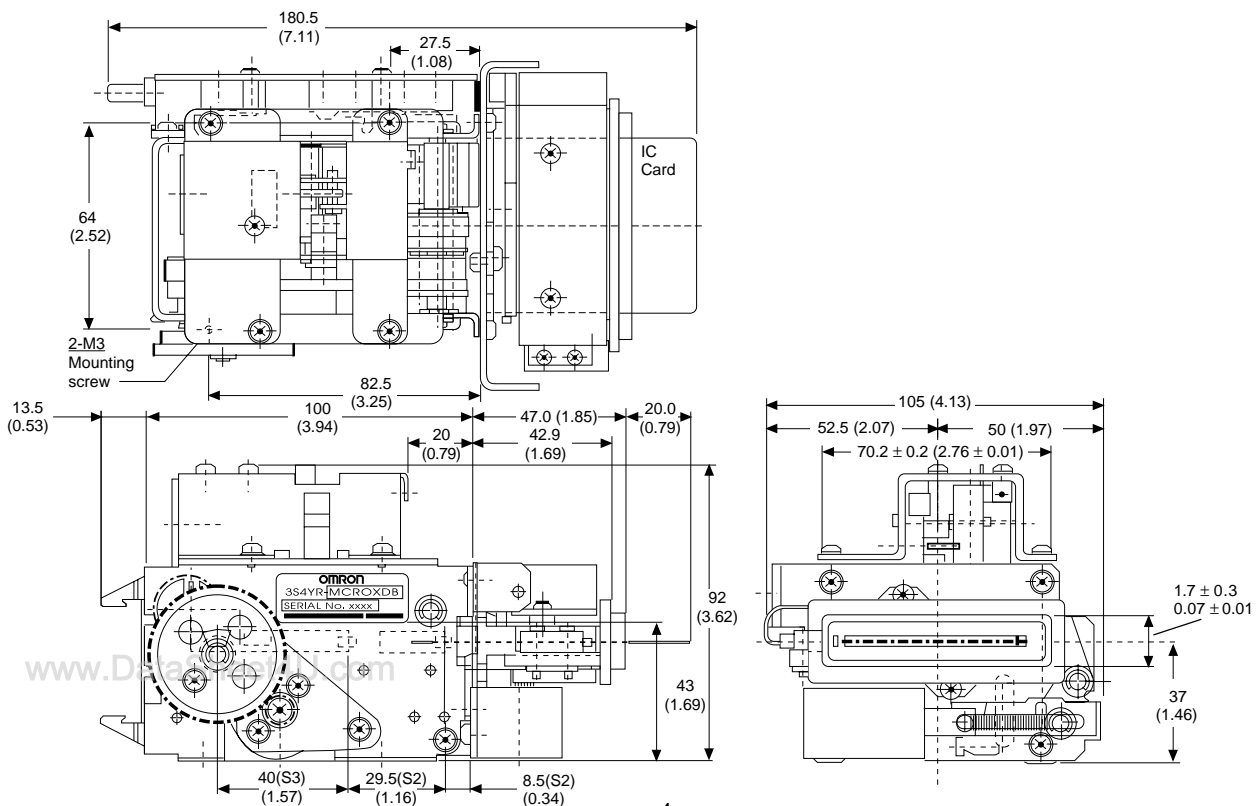

NOTE: DIMENSIONS ARE SHOWN IN MILLIMETERS. To convert millimeters to inches divide by 25.4.

OMRON

OMRON ELECTRONICS, INC.

One East Commerce Drive
Schaumburg, IL 60173

1-800-55-OMRON

OMRON CANADA, INC.

885 Milner Avenue
Scarborough, Ontario M1B 5V8

416-286-6465