

## Built-in Amplifier Photoelectric Sensor

## E3V3

### Easy-to-use, Low-cost Photoelectric Sensor

- Incorporating indicators that can be clearly seen from a distance
- Conforms to EN and IEC standards
- Incorporating polarizing function, thus accurately detecting shiny objects
- Resin-filled construction resists vibration and ensures IP67 water-resistance
- 2 meter attached cable



## Ordering Information

Connections	Supply voltage	Sensing type	Sensing range	Output		Part number				
				Mode	Type					
Pre-leaded	12 to 24 VDC	Through-beam	7 m (23 ft)	Light-ON/Dark-ON (selectable by wiring)	NPN	E3V3-T61				
						Polarized retroreflective	2 m (6.6 ft)	PNP	E3V3-T81	
								Diffuse reflective	0.5 to 8 cm (0.20 to 3.15 in)	NPN
		PNP	E3V3-R81							
		70 cm (2.3 ft)	NPN			E3V3-D61				
			PNP			E3V3-D81				
			PNP			E3V3-D82				
		Pigtail lead with M8 connector	12 to 24 VDC			Through-beam	7 m (23 ft)	Light-ON/Dark-ON (selectable by wiring)	NPN	E3V3-T61-M3J
										Polarized retroreflective
Diffuse reflective	0.5 to 8 cm (0.20 to 3.15 in)			NPN	E3V3-R61-M3J					
				PNP	E3V3-R81-M3J					
70 cm (2.3 ft)	NPN			E3V3-D61-M3J						
	PNP			E3V3-D81-M3J						
	PNP			E3V3-D82-M3J						

Note: Mounting brackets are not provided with the E3V3. Order them separately below.

### CONNECTOR CORDSETS

Description	Part number
Straight connector, 2 m (6.56 ft), 4-conductor cable	XS3F-M421-402-R
Straight connector, 5 m (16.4 ft), 4-conductor cable	XS3F-M421-405-R
Extension cable, 2 m (6.56 ft), connectors at both ends	XS3W-M421-402-R
Extension cable, 5 m (16.4 ft), connectors at both ends	XS3W-M421-405-R

## ■ ACCESSORIES

Description		Part number
Slits for through-beam type, set of 3 pairs includes 0.5 mm, 1 mm and 2 mm slits		<b>E39-S7</b>
Reflectors	Corner cube type	5 to 100 cm (2.0 in to 1.64 ft) <b>E39-R3</b>
	Glass bead, adhesive back	20 to 50 cm (7.9 in to 19.7 in) <b>E39-RSA</b>
		20 to 80 cm (7.9 in to 31.5 in) <b>E39-RSB</b>
Optional mounting brackets	Side mounting bracket	<b>E39-L43</b>
	Rear-mounting bracket	<b>E39-L44</b>
	Rotating post bracket	<b>E39-L93</b>
	Metal cover bracket	<b>E39-L98</b>
	Vertical mounting bracket	<b>E39-L104</b>
	For E39-R1 reflector	<b>E39-L7</b>

## ■ REPLACEMENT PART

Description	Part number
Reflector supplied with each retroreflective sensor	<b>E39-R1</b>

## Specifications

Sensing method	Through-beam	Retroreflective (with MSR function)	Diffuse reflective	
NPN output	E3V3-T61	E3V3-R61	E3V3-D61	E3V3-D62
PNP output	E3V3-T81	E3V3-R81	E3V3-D81	E3V3-D82
LED light source	Infrared LED	Red LED	Infrared LED	
Sensitivity adjustment	Adjustor			
Connection method	Pre-leaded: 2 m (6.6 ft)			
Weight	Approx. 160 g (with 2-m cord)	Approx. 80 g (with 2-m cord)		
Mode	Wire selectable (Light-ON or Dark-ON)			
Circuit protection	Overload protection, reversed connection protection, and mutual interference prevention function (except for through-beam models)			
Indicators	Operation indicator (orange), stability indicator (green), emission indicator for through-beam models only (orange)			
Materials	Case	Heat-resistant ABS		
	Lens	Methacrylic resin		
Attachments	Instruction sheet and reflector (E39-R1 retroreflective model only) (See Note.)			

Note: The mounting brackets are sold separately.

## ■ RATINGS/CHARACTERISTICS

Part number	E3V3-T61/-T81		E3V3-R61/-R81	E3V3-D61/-D81	E3V3-D62/-D82
Sensing method	Through-beam		Retroreflective (with MSR function)	Diffuse reflective	
Supply voltage	12 to 24 VDC $\pm$ 10%, ripple (p-p): 10% max.				
Current consumption	50 mA max.		40 mA max.		
Detection distance	7 m		0.1 to 2 m (with E39-R1)	0.5 to 8 cm	70 cm
Standard detectable object	Opaque object: 7 mm min. (0.28 in)		Opaque object: 30 mm min. (1.18 in)	10 x 10 cm white paper	20 x 20 cm white paper
Directional angle	3° to 15°		Receiver/Emitter: 2° to 10° Reflector: 30° min.	---	
Differential travel	---			20% max. of detection distance	
Response time	1 ms max. for both operation and release				
Control output	100 mA max. at 30 VDC, open collector output (residual voltage: 1 V max.)				
Ambient illumination	Incandescent lamp	Illumination on optical spot: 3,000 lx max.			
	Sunlight	Illumination on optical spot: 10,000 lx max.			
Ambient temperature	Operating	-25°C to 55°C (-13°F to 131°F) with no icing			
	Storage	-40°C to 70°C (-40°F to 158°F)			
Relative humidity	Operating	35% to 85%			
	Storage	35% to 95%			
Insulation resistance	20 M $\Omega$ min. (at 500 VDC)				
Dielectric strength	1,000 VAC, 50/60 Hz for 1 min				
Vibration resistance	10 to 55 Hz, 1.5-mm double amplitude for 2 hrs each in X, Y, and Z directions				
Shock resistance	500 m/s <sup>2</sup> (approx. 50G) 3 times each in X, Y, and Z directions				
Enclosure rating	IEC	IP67			

DataSheet4U.com

# Engineering Data

## ■ PARALLEL OPERATING RANGE (TYPICAL)

E3V3-T□1

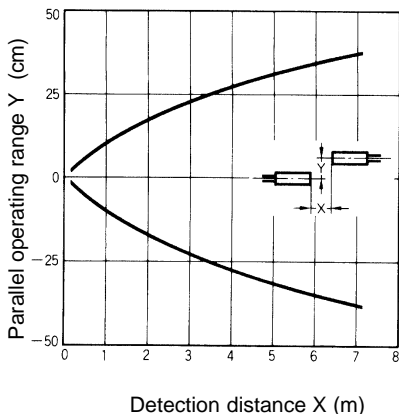

## ■ REFLECTOR PARALLEL MOVEMENT (TYPICAL)

E3V3-R□1

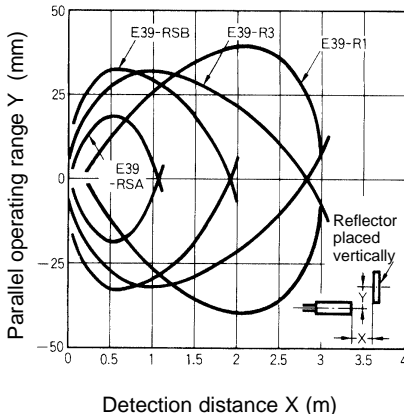

## ■ OPERATING RANGE (TYPICAL)

E3V3-D□2

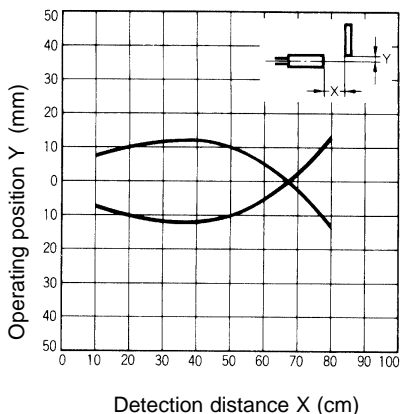

## ■ DETECTION DISTANCE VS. OBJECT SIZE (TYPICAL)

E3V3-D□2

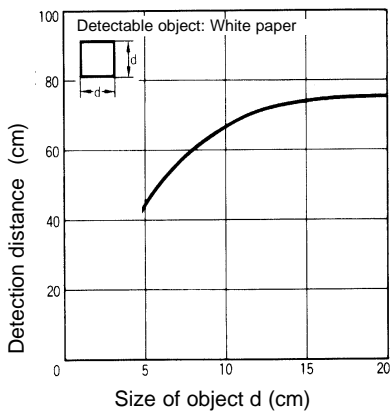

## ■ COLOR OF OBJECT VS. OPERATING RANGE (TYPICAL)

E3V3-D□1

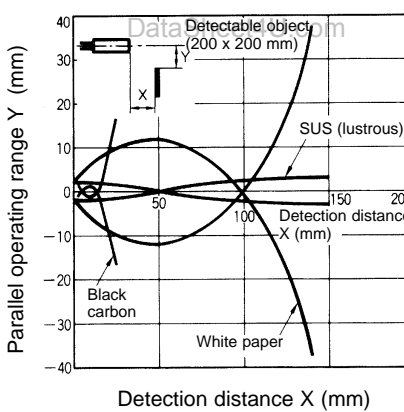

## ■ DETECTION DISTANCE VS. OBJECT SIZE (TYPICAL)

E3V3-D□1

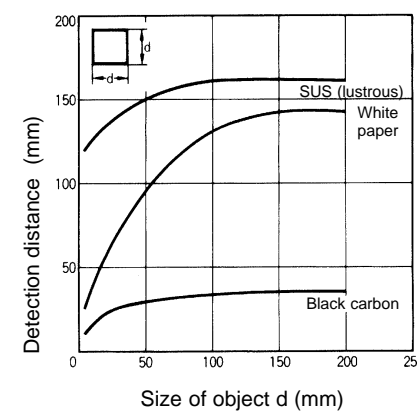

et4U.com

DataShee

■ EXCESS GAIN VS. SET DISTANCE (TYPICAL)

E3V3-T□1

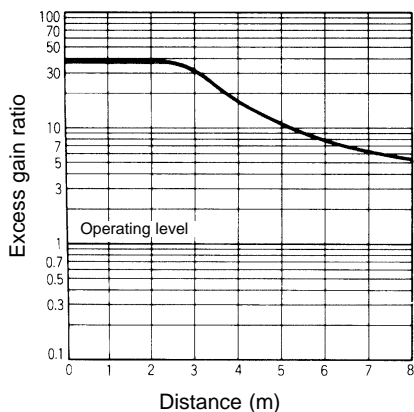

E3V3-R□1

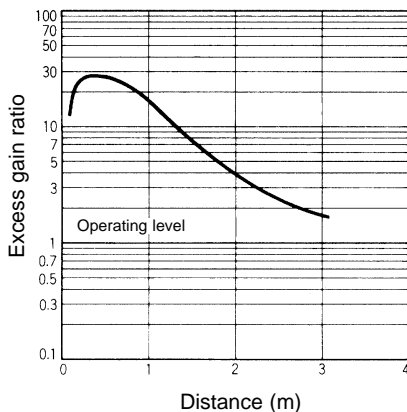

E3V3-D□2

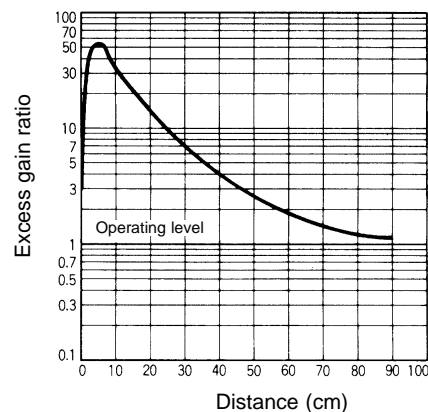

E3V3-D□1

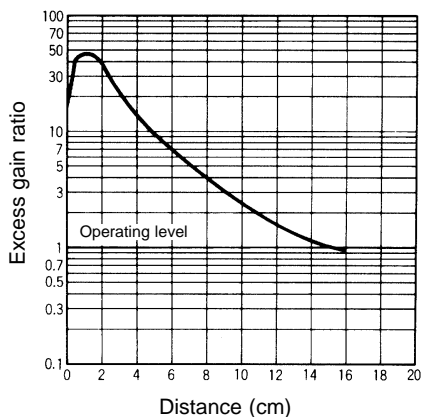

Operation

■ OUTPUT CIRCUITS

Output Configuration	Mode Switch	Connection Method	Output Circuits
NPN (E3V3-□6□)	Light-ON	Connect the pink cord to the brown cord. (See Note.)	<p><b>Connector Pin Arrangement</b></p>
	Dark-ON	Connect the pink cord to the blue cord or disconnect the pink cord from the blue cord. (See Note.)	<p><b>Connector Pin Arrangement</b></p>

Output Configuration	Mode Switch	Connection Method	Output Circuits
PNP (E3V3-□8□)	Light-ON	Connect the pink cord to the brown cord. (See Note.)	<p>Connector Pin Arrangement</p>
	Dark-ON	Connect the pink cord to the blue cord or disconnect the pink cord from the blue cord. (See Note.)	<p>Connector Pin Arrangement</p>

Note: The E3V3 Model with a junction connector has a white cord instead of a pink cord.

### Emitter (NPN/PNP)

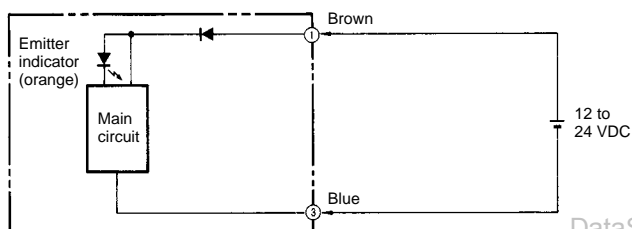

### Connector Pin Arrangement



## TIMING CHARTS

Output Configuration	Mode Switch	Connection Method	Timing Chart
NPN (E3V3-□6□)	Light-ON	Connect the pink cord to the brown cord. (See Note.)	
	Dark-ON	Connect the pink cord to the blue cord or disconnect the pink cord from the blue cord. (See Note.)	
PNP (E3V3-□8□)	Light-ON	Connect the pink cord to the brown cord. (See Note.)	
	Dark-ON	Connect the pink cord to the blue cord or disconnect the pink cord from the blue cord. (See Note.)	

Note: The E3V3 Model with a junction connector has a white cord instead of a pink cord.

## ■ SENSITIVITY ADJUSTMENT (REFLECTIVE SENSORS)

### (Diffuse reflective model in light-ON mode)

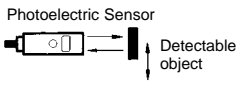
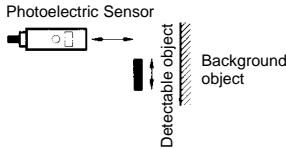
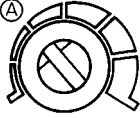
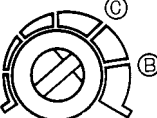
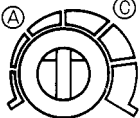
Item	Position A	Position B	Setting
Sensing condition	 <p>Photoelectric Sensor Detectable object</p>	 <p>Photoelectric Sensor Detectable object Background object</p>	---
Sensitivity adjustor	 <p>A</p>	 <p>C B</p>	 <p>A C</p>
Indicators	<p>OFF      ON</p> <p>○ STABILITY (green)      ● OPERATION (orange)</p>	<p>OFF      OFF</p> <p>○ STABILITY (green)      ○ OPERATION (orange)</p>	<p>OFF      ON</p> <p>● STABILITY (green)      ○ OPERATION (orange)</p>
Procedure	<p>Locate the sensing object at the detection distance of the E3V3 and turn the sensitivity adjustor clockwise to increase the sensitivity of the E3V3 until the orange operation indicator is lit. The moment the orange operation indicator is lit, stop turning the sensitivity adjustor, the position of which is point A.</p>	<p>Remove the sensing object and turn the sensitivity adjustor clockwise until the E3V3 detects the background object and the orange operation indicator is lit. The moment the orange operation indicator is lit, stop turning the sensitivity adjustor, the position of which is point B. Turn the sensitivity adjustor counterclockwise to decrease the sensitivity of the E3V3 until the orange operation indicator is off. The moment the orange operation indicator is off, stop turning the sensitivity adjustor, the position of which is point C.</p> <p>If there is no background object, point C is where the sensitivity adjustor is set to maximum.</p>	<p>Set the sensitivity adjustor midway between points A and C, where the best sensitivity of the E3V3 for the sensing object is ensured, and make sure that the green stability indicator is lit with and without the sensing object at that position of the sensitivity adjustor. If the green stability is not lit, try another sensing method.</p>

Note: The rotation range of the sensitivity adjustor is 240°. Do not try to turn the sensitivity adjustor clockwise or counterclockwise excessively, otherwise the sensitivity adjustor will break.

# Dimensions

Unit: mm (inch)

## E3V3-T□□

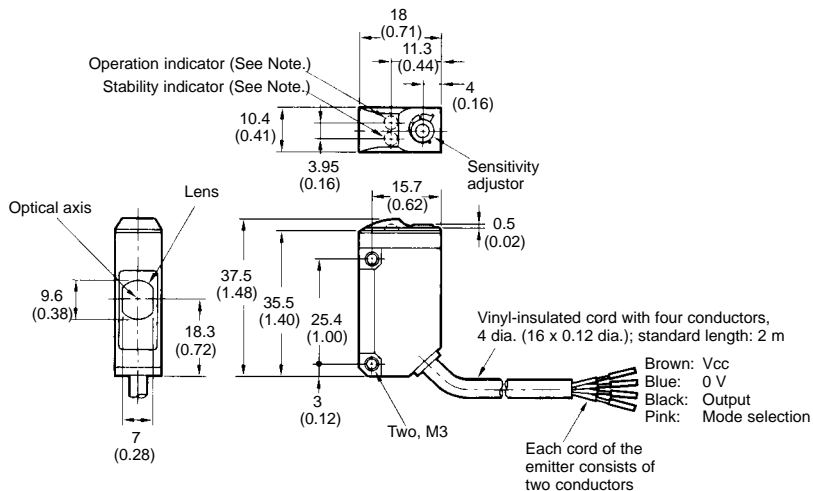
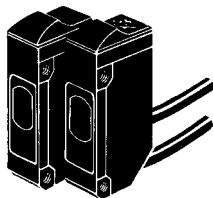

Note: The emitter has no indicators except for an emission indicator.

## E3V3-D□□

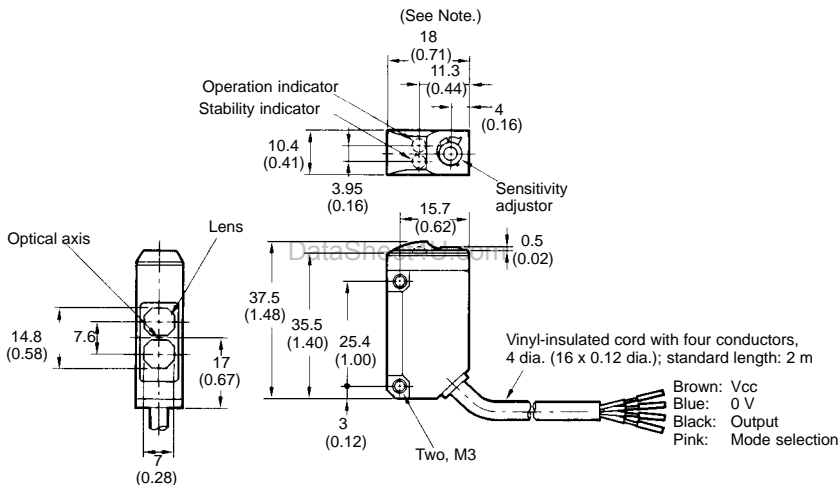
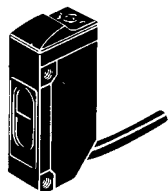

Note: 18.4 (0.72) for E3V3-D61/-D81.

## E3V3-R□□

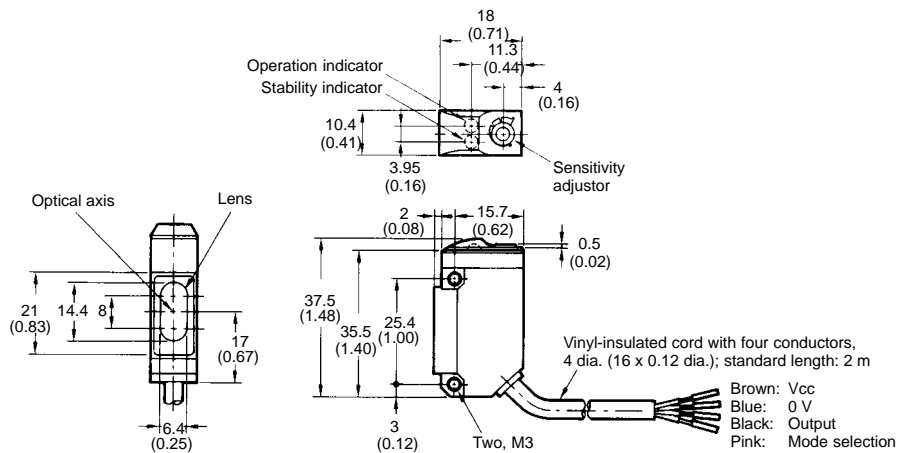
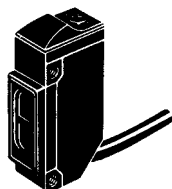



REFLECTORS

E39-R1 Retroreflector

Provided with the E3V3-R61/-R81

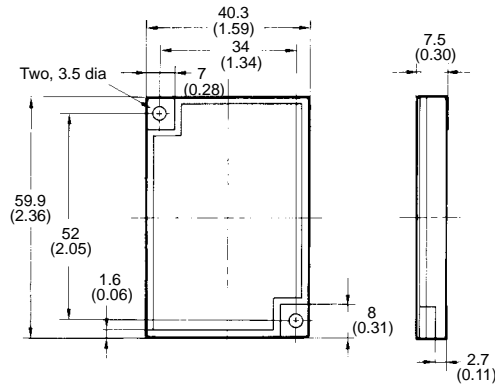

E39-R3 Retroreflector (Small Type)

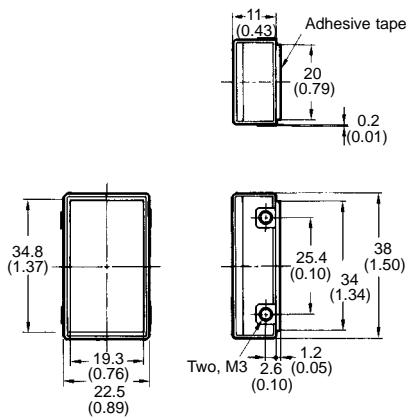

With Mounting Bracket (Sold Together)

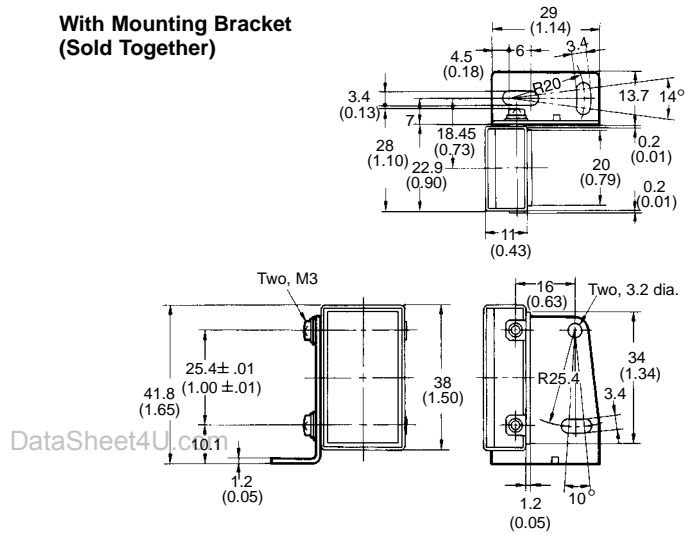

E39-RSA Retroreflector (Tape Type)

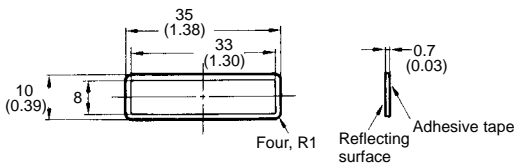

E39-RSB Retroreflector (Tape Type)

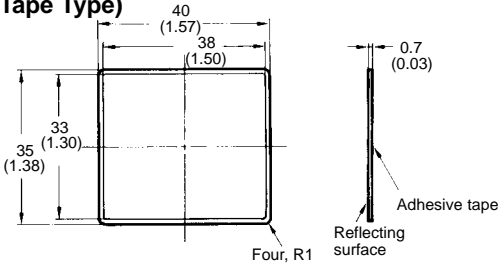

MOUNTING BRACKETS

E39-L104

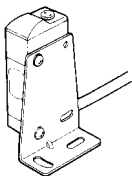

E39-L44

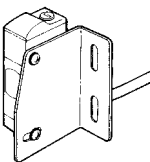

E39-L43

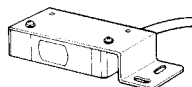

E39-L98

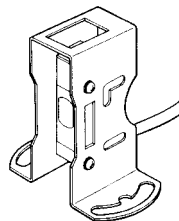

E39-L93

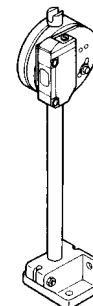

E39-L104 Mounting Bracket

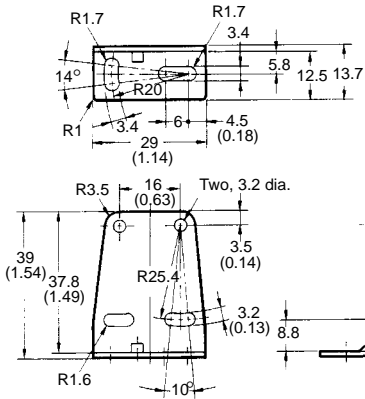

With Mounting Bracket (E3V3-D62)

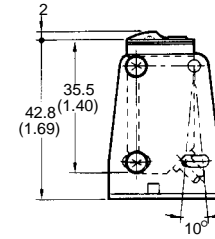
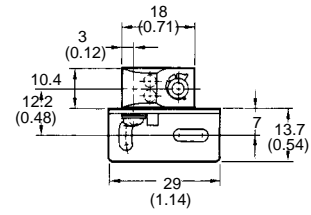
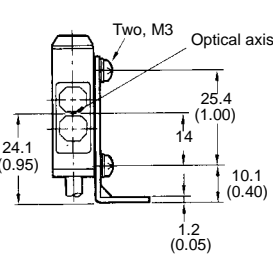

E39-L44

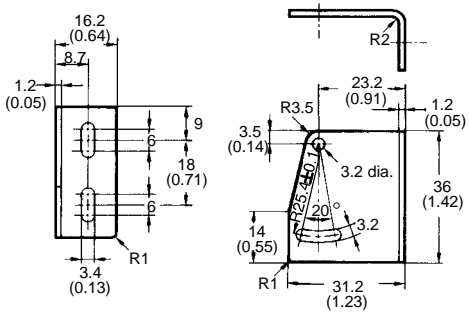

With Mounting Bracket (E3V3-D62)

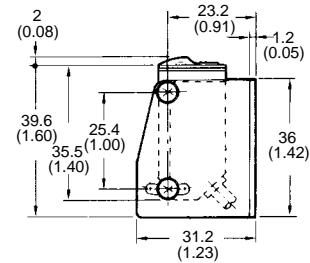
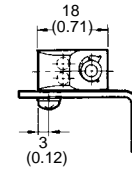
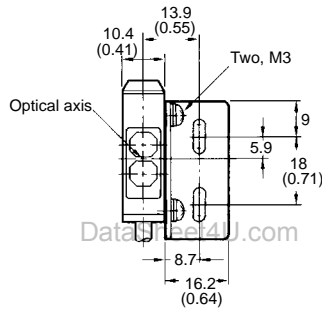

E39-L43

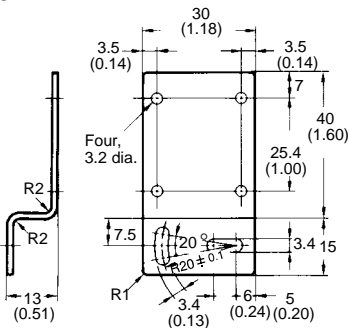

With Mounting Bracket (E3V3-D62)

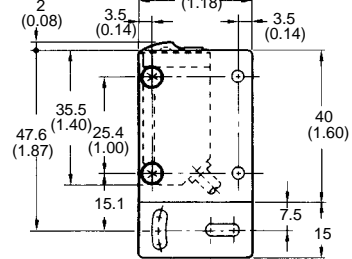
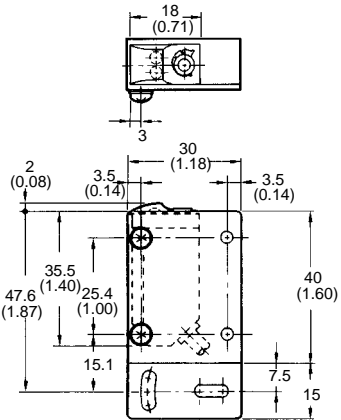
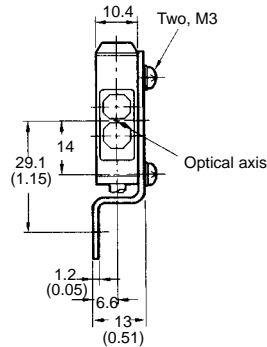

E39-L98

With Mounting Bracket (E3V3-D62)

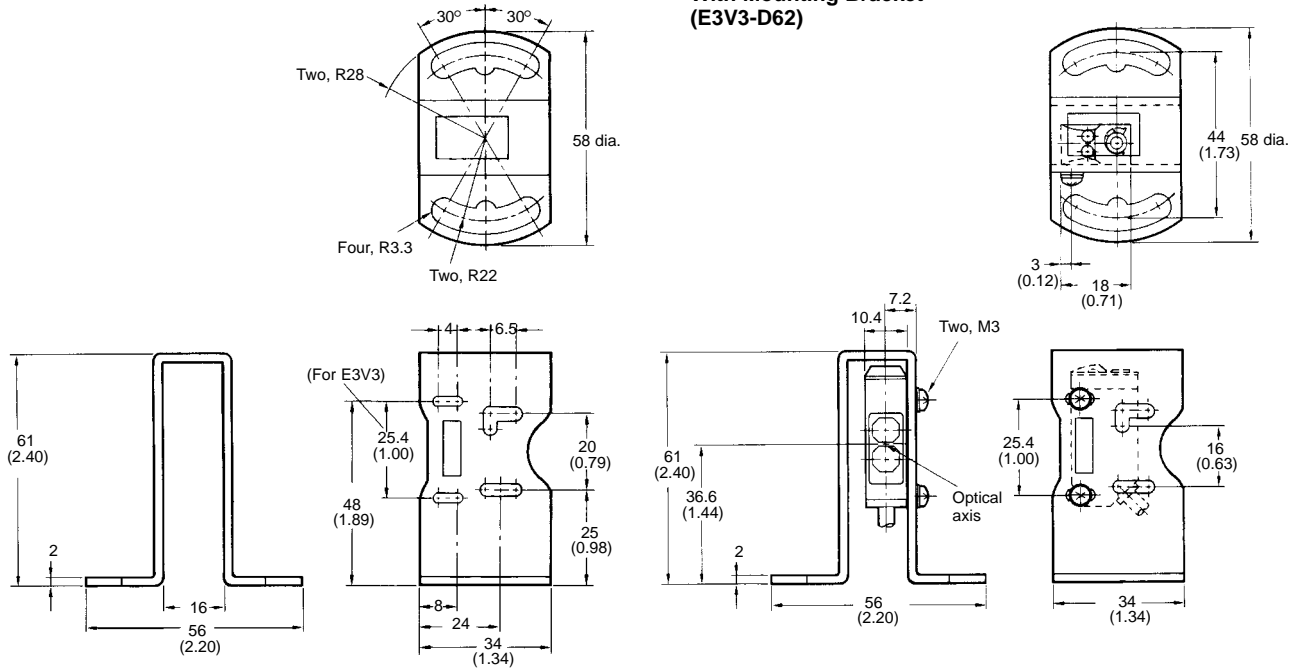

E39-L93

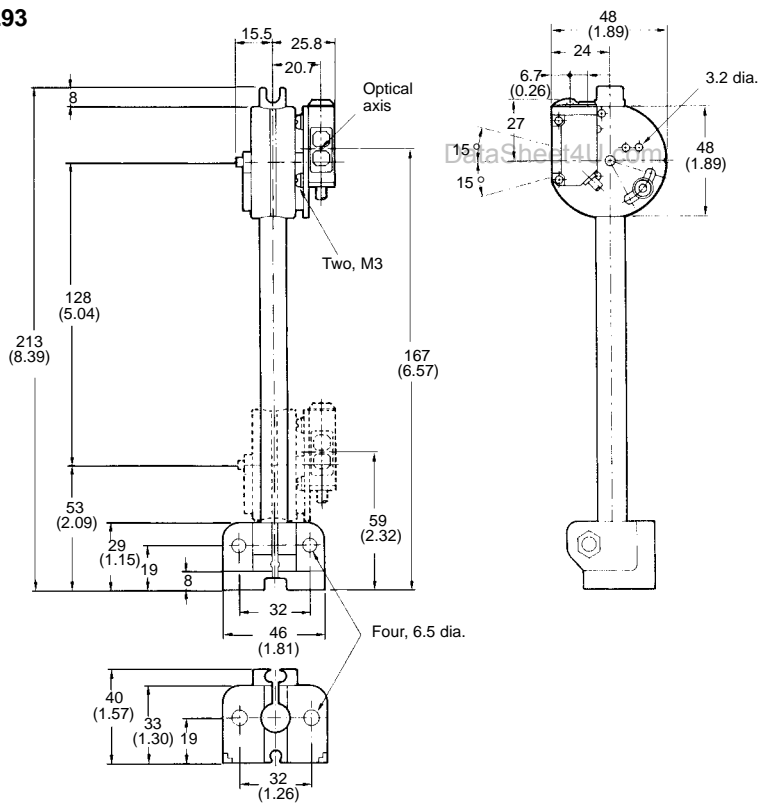

et4U.com

DataShee

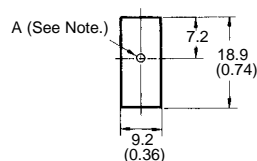
**E39-S7 Slits for E3V3-T□□****(Two Pairs; a Total of 6 Slits)**

- Note:
1. A: 0.5, 1, or 2 dia.
  2. Attach an E39-S7 Slit to both the emission panel of the emitter and the receiver's sensing panel of the E3V3-T□□.

**Detection Distance (Rating)**

Slit size	0.5 dia.	1 dia.	2 dia.
Emitter and receiver	25 mm (0.98)	100 mm (3.94)	400 mm (15.75)
Receiver	400 mm (15.75)	800 mm (31.50)	1,500 mm (59.06)

**Precautions****■ POWER SUPPLY**

The permissible voltage imposed on the E3V3 must be 24 VDC + 10% maximum (i.e., 26.4 V). Make sure that the voltage imposed on the E3V3 is correct before turning the E3V3 on.

If a standard switching regulator is used as a power supply, the frame ground (FG) terminal and the ground (G) terminal must be grounded, or the E3V3 may malfunction due to the switching noise of the power supply.

**■ OPERATION OF THE E3V3 WITH POWER TURNED ON**

The E3V3 is ready to detect objects within 100 ms after the E3V3 is turned on. If the E3V3 and the load connected to the E3V3 each use an independent power supply, be sure to turn on the E3V3 first and then the load.

**■ CONNECTION**

If the input/output lines of the photoelectric sensor are placed in the same conduit or duct as power lines or high-voltage lines, the photoelectric sensor could be induced to malfunction, or even be damaged by electrical noise. Either separate the wiring, or use shielded lines as input/output lines to the photoelectric sensor.

The cord connected to the E3V3 can be extended up to 100 m provided that the diameter of each wire of the cord is 0.3 mm<sup>2</sup> minimum.

**■ WATER RESISTANCE**

Do not use the E3V3 in water, in the rain, or outdoors.

**■ MOUNTING**

When mounting the E3V3, do not hit the E3V3 with a hammer, or the E3V3 will lose watertightness.

Use M3 screws to mount the E3V3.

Move the E3V3 up, down, left, and right to find the range where the operating indicator is lit or unlit. Then locate the E3V3 in the center of the range, and make sure that the stability indicator is lit.

**■ PRECAUTIONS WHEN USING THE E39-R3, E39-RSA, OR E39-RSB REFLECTOR**

Before applying adhesive tape to the reflector, make sure that the reflector is free from oil or dust, or the adhesive tape will not stick to the reflector properly.

Do not cut or scratch the reflector or the reflector will lose watertightness.

Do not press the reflector with a metal object or a nail, or the reflector will not function properly.

**! WARNING**

The E3V3 is not a safety component for ensuring the safety of people as defined in EC directive 91/368/EEC, or as covered by separate European standards or by any other regulations or standards.

**NOTE: DIMENSIONS SHOWN ARE IN MILLIMETERS. To convert millimeters to inches divide by 25.4.**

**OMRON**<sup>®</sup>**OMRON ELECTRONICS, INC.**One East Commerce Drive  
Schaumburg, IL 60173**1-800-55-OMRON****OMRON CANADA, INC.**885 Milner Avenue  
Scarborough, Ontario M1B 5W8**416-286-6465**