

SIF Ceramic Filters

Type: **S**

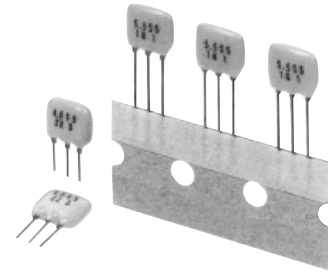

SIF Ceramic Filters have lower insertion loss and provide better spurious suppression characteristics, compared with conventional LC filters, because they use a worldwide patented "PCM" Piezo-electric material as a filter element, which features low resonant resistance and high stability against temperature changes.

■ Features

- Excellent frequency vs. attenuation characteristics
- Excellent spurious suppression characteristics
- Low insertion loss
- Contributes to circuit simplification because it is adjustment-free
- RoHS compliant

■ Recommended Applications

- Bandpass filter for TVs SIF-stage
- Bandpass filter for VCRs SIF-stage
- Killer circuit for VCRs (PAL, SECAM)
- Recording/Reproducing circuit for VCRs (PAL, SECAM)

■ Handling Precautions (See Page 181)

■ Packaging Specifications

See Page 208

■ Explanation of Part Numbers

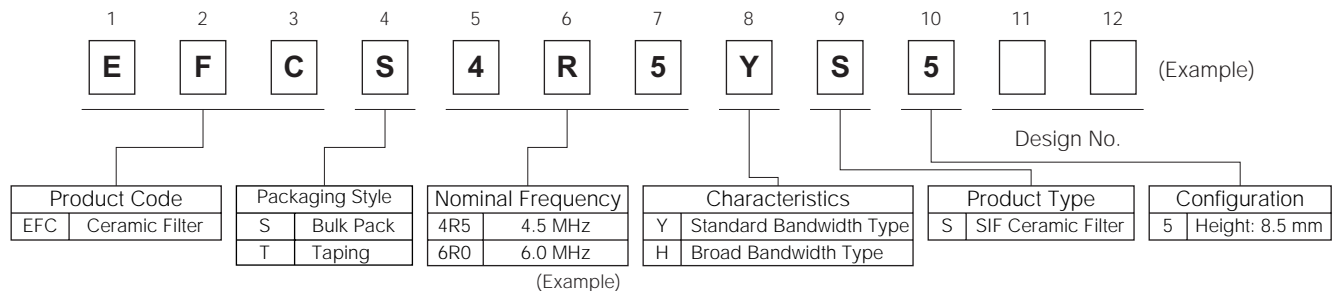

■ Ratings and Characteristics

① For TV, VCR

Part No.		Nominal Frequency	Center Frequency (f ₀)	Insertion Loss	Bandwidth		Spurious Response	
Bulk Pack	Taping				-3 dB	-20 dB	0-F ₀	F ₀ -10 MHz
EFCS4R5YS5A	EFCT4R5YS5A	4.5 MHz	4.5 MHz ±30 kHz	6 dB max.	±60 kHz min. 550 kHz max.	30 dB min.	20 dB min.	
EFCS5R5YS5A	EFCT5R5YS5A	5.5 MHz	5.5 MHz ±30 kHz	6 dB max.	±75 kHz min. 600 kHz max.	30 dB min.	20 dB min.	
EFCS5R74YS5A	EFCT5R74YS5A	5.74 MHz	5.775 MHz ±30 kHz	6 dB max.	±75 kHz min. 600 kHz max.	30 dB min.	20 dB min.	
EFCS6R0YS5A	EFCT6R0YS5A	6.0 MHz	6.0 MHz ±30 kHz	6 dB max.	±75 kHz min. 600 kHz max.	30 dB min.	20 dB min.	
EFCS6R5YS5A	EFCT6R5YS5A	6.5 MHz	6.5 MHz ±30 kHz	6 dB max.	±80 kHz min. 600 kHz max.	30 dB min.	20 dB min.	

- Operating Temperature Range: -20 to 80 °C

Note : If customer used other frequency, please ask us separately.

② For Multiplex Broadcasting

EFCS4R5HS5	EFCT4R5HS5	4.5 MHz	—	6 dB max.	±100 kHz min. 900 kHz min.	30 dB min.	20 dB min.
------------	------------	---------	---	-----------	----------------------------	------------	------------

Design and specifications are each subject to change without notice. Ask factory for the current technical specifications before purchase and/or use. Should a safety concern arise regarding this product, please be sure to contact us immediately.

■ Dimensions in mm (not to scale)

● Bulk Pack

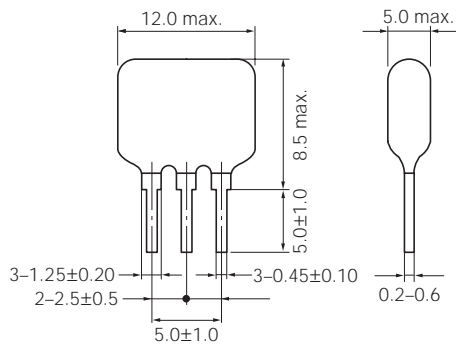

■ Typical Characteristics

Spurious Response

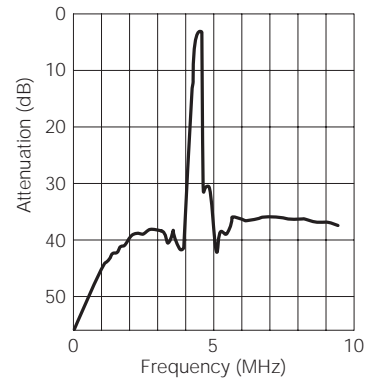

■ Test Circuit Diagram

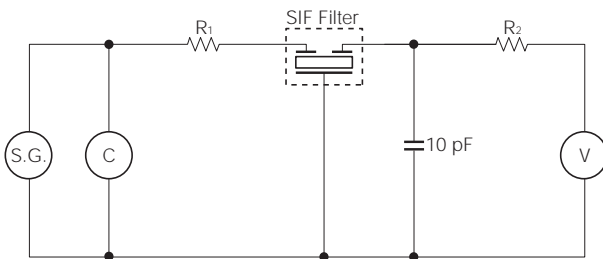

C : Frequency counter
S.G. : Signal generator
V : Voltmeter

Input/Output Impedance

Nominal Frequency	R ₁ , R ₂
4.50 MHz	1000 Ω
5.50 MHz	470 Ω
5.74 MHz	
6.00 MHz	
6.50 MHz	

■ Dimensions for Taping in mm (not to scale)

● Taping

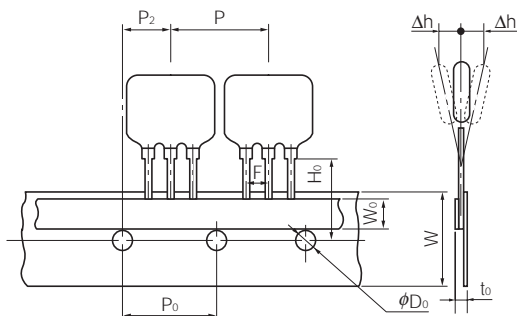

Dimensions	
P	12.7±1.0
P ₀	12.7±0.3
P ₂	6.35±1.30
H ₀	18.50±0.75
F	2.5±0.8
Δh	2.0 max.
W	18.0±1.0
W ₀	6.0 min.
φD ₀	4.0±0.2
t ₀	1.5 max.

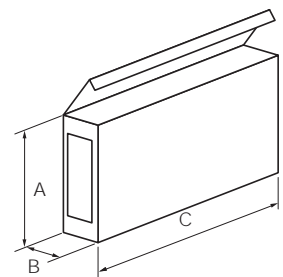

Dimensions*	
A	160 to 170
B	40 to 45
C	330

* Tolerance: ±3 mm

● Standard Packing Quantity

Taping Pack	Bulk Pack
1000 pcs./box	4000 pcs./box