



www.datasheet

ANDpSi104EA5S-4HB-KIT

10.4" XGA Color p-Si TFT LCD Module

The ANDpSi104EA5S-4HB-KIT is 1024 x 768 Color TFT display and inverter that utilizes new poly-silicon (p-Si) technology to provide a brighter, thinner and lighter display with high-resolution. The p-Si TFT technology allows the row and column LCD drivers to be fabricated directly on the LCD glass. This eliminates the need for discrete TAB drivers. This reduces the thickness, weight and overall size of the display. The LVDS interface allows fast data transfer. The triple CCFL backlight offers an ultra-high bright display. This makes the display ideal for outdoor, sunlight readable applications.

Features

- p-Si construction with drivers on glass
- High luminance
- Triple CCFL backlight
- 6-bit (256K) or 8-bit (16.7M)
- 10.4" XGA (1024 x 768 pixels color display)
- LVDS Interface system
- High-bright, Display Terminals, Scientific, Medical, Test & Measurement Instruments, and Office Automation Equipment

Mechanical Characteristics

Item	Specification	Unit
Outline Dimensions	237.7 (W) x 173.2 (H) x 14.6 max (D)	mm
Number of Pixels	1024 (W) x 768 (H)	pixels
Active Area	210.432 (W) x 157.824 (H)	mm
Pixel Pitch	0.2055 (W) x 0.2055 (H)	mm
Weight (approx.)	465	gram
Backlight	3 CCFL, high-bright	-

Absolute Maximum Ratings

Item	Symbol	Min.	Max.	Unit
Supply Voltage	V_{DD}	-0.3	4.0	V
	V_{FL}	0	2.0	kVrms
FL Driving Frequency	f_{FL}	-	100	kHz
Input Signal Voltage	V_{IN}	-0.3	$V_{DD} + 0.3$	V
Operating Temperature	T_{op}	0	50	°C
Storage Temperature	T_{stg}	-20	60	°C
Humidity	-	10	90	% RH

Electrical Characteristics (Ta = 25°C)

Item	Symbol	Min.	Typ.	Max.	Unit
Supply Voltage $I_{FL}=5$ mA(rms)	V_{DD}	3.0	3.3	3.6	V
	V_{FL}	-	(600)	-	V(rms)
FL Start Voltage (Ta = 0°C)	-	1200	-	-	V(rms)
Differential Input High Threshold	V_{IH}	(V_{IS})+0.1	-	-	V
Differential Input Center Threshold	V_{IS}	0.5	1.2	1.5	V
Differential Input Low Threshold	V_{IL}	-	-	(V_{IS})-0.1	V
Current Consumption	I_{DD} (*2)	-	250	-	mA(rms)
	I_{FL} (*3)	2.0	7.0	7.5	
Power Consumption (*2, *3) @ 890cd/m ²	-	-	(15)	-	W

*1: Refer to "Timing Chart" and LVDS (THC63LVDF84A-85) specifications by Thine Electronics, Inc. corporation.

*2: 8 color bars pattern

*3: Excepting the efficiency FL inverter

Optical Characteristics (Ta = 25°C)

Item	Symbol	Min.	Typ.	Max.	Unit
Contrast	CR	100	250	-	-
Response	t_{on}	-	-	50	ms
	t_{off}	-	-	50	ms
Luminance $I_{FL}=7$ mA(rms)	L	140	1000	-	cd/m ²
Viewing Angle	L/R	-	60/60	-	°
	U/D	-	45/45	-	°

Product specifications contained herein may be changed without prior notice.

It is therefore advisable to contact Purdy Electronics before proceeding with the design of equipment incorporating this product.

Dimensional Outline

www.datasheet4u.com

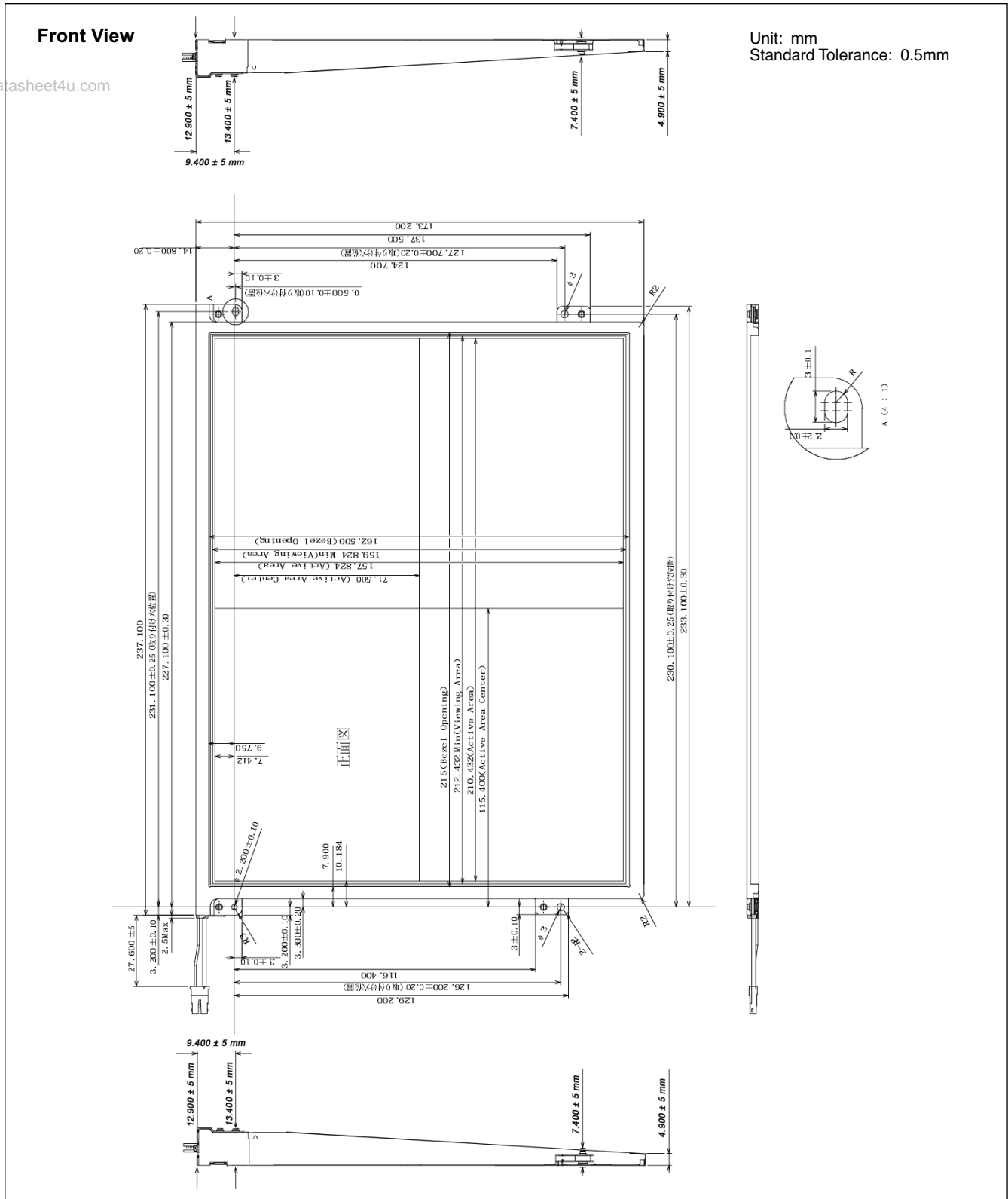

Timing Specifications

Item	Symbol	Min	Typ	Max	Unit
Frame Period	t1	778 x t4 -	- -	860 x t4 -	- ms
Vertical Display Term	t2	768 x t4	768 x t4	768 x t4	-
Vertical Blanking Term	t3	10 x t4	-	92 x t4	-
1 Line Scanning Time	t4	1319 x t7 20.04	- -	1600 x t7 -	us
Horizontal Display Term	t5	1024 x t7	1024 x t7	1024 x t7	-
Horizontal Blanking Term	t6	295 x t7	-	500 x t7	-
Clock Period	t7	15	15.38	-	ns
V-Sync Pulse Width	twv	3 x t4	-	7 x t4	-
V-Sync Set up Time	tvsu	8 x t7	-	-	-
V-Sync Hold Time	tvhd	thbp+16 x t7	-	-	-
Vertical Front Porch	tvfp	2 x t4	-	-	-
Vertical Back Porch	tvbp	6 x t4	-	-	-
Horizontal Period	th	1319 x t7 20.04	-	1600 x t7 -	- us
H-Sync Pulse Width	thw	8 x t7	-	-	-
Horizontal Front Porch	thfp	4 x t7	-	500 x t7	-
Horizontal Back Porch	thbp	8 x t7	-	492 x t7	-
thw+thbp		16 x t7	-	500 x t7	-
DE Pulse Width	twde	1024 x t7	1024 x t7	1024 x t7	-

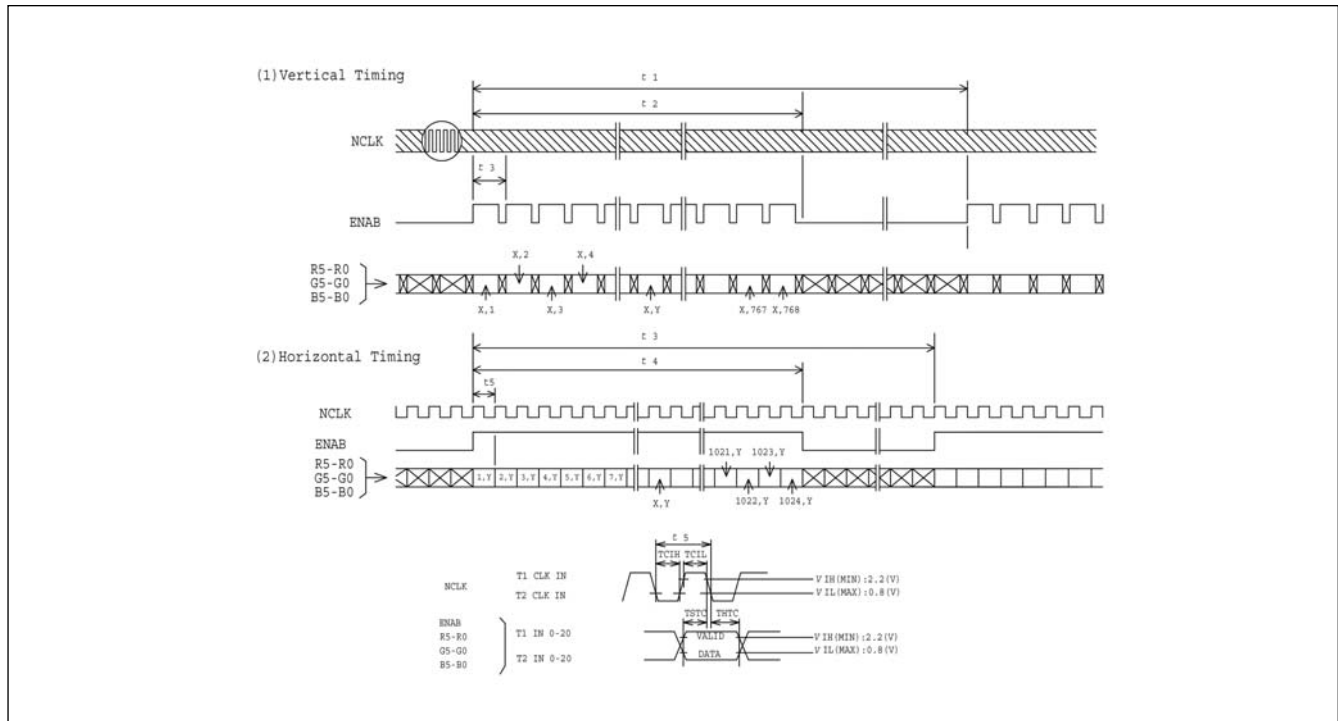
Timing Chart



www.datasheet4u.com

Recommended Inverter:

Block Diagram

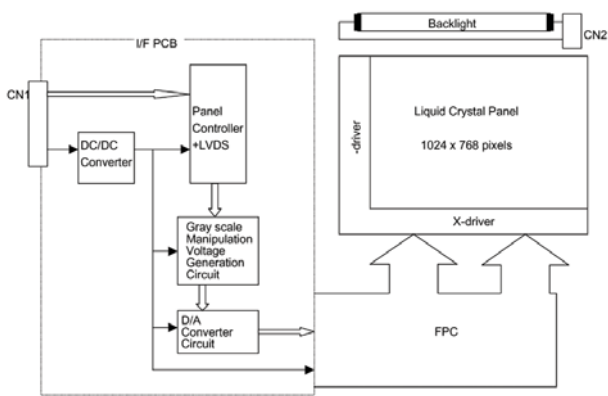

1) Drivers are fabricated on the LCD glass

2) Connectors

DF19L-14P-1H/Hirose Electric Co., Ltd.
Mating Connector - DF19G-14S-11C/Hirose

HV-2S-C1/Japan Aviation Electronics Industry., Ltd.
Mating Connector - HV-2P-HF/JAEI

Connector Pin Assignment for Interface

CN1 Input Signal (1)

Terminal No.	Symbol	Function
1	V _{DD}	+3.3V Power Supply
2	V _{DD}	+3.3V Power Supply
3	GND	Ground
4	GND	Ground
5	IN0-	Trans Data of Pixels 0 (Negative : -)
6	IN0+	Trans Data of Pixels 0 (Positive : +)
7	IN1-	Trans Data of Pixels 1 (Negative : -)
8	IN1+	Trans Data of Pixels 1 (Positive : +)
9	IN2-	Trans Data of Pixels 2 (Negative : -)
10	IN2+	Trans Data of Pixels 2 (Positive : +)
11	CLK-	Sampling Clock (Negative : -)
12	CLK+	Sampling Clock (Positive : +)
13	GND	Ground
14	GND	Ground

CN2 CCFL Power Source

Terminal No.	Symbol	Function
1	V _{FLL}	CCFL Power Supply (Low Voltage)
2	V _{FLH}	CCFL Power Supply (High Voltage)

Recommended Transmitter (DS90CF363) to AND10pSi104EAS-HB Interface Assignment: 6-bit Transmitter

DS90CF363				ANDpSi10C313U		
Input Terminal No.		Input Signal (Graphics controller output signal)		Output Signal Symbol	Interface (CN1)	
Symbol	DS90CF363	Symbol	Function		Terminal	Symbol
TIN0	44	R0	Red Pixels Display Data (LSB)	TOUT0- TOUT0+	No.5 No.6	IN0- IN0+
TIN1	45	R1	Red Pixels Display Data			
TIN2	47	R2	Red Pixels Display Data			
TIN3	48	R3	Red Pixels Display Data			
TIN4	1	R4	Red Pixels Display Data			
TIN5	3	R5	Red Pixels Display Data (MSB)			
TIN6	4	G0	Green Pixels Display Data (LSB)	TOUT1- TOUT1+	No.7 No.8	IN1- IN1+
TIN7	6	G1	Green Pixels Display Data			
TIN8	7	G2	Green Pixels Display Data			
TIN9	9	G3	Green Pixels Display Data			
TIN10	10	G4	Green Pixels Display Data			
TIN11	12	G5	Green Pixels Display Data (MSB)			
TIN12	13	B0	Blue Pixels Display Data (LSB)	TOUT2- TOUT2+	No.9 No.10	IN2- IN2+
TIN13	15	B1	Blue Pixels Display Data			
TIN14	16	B2	Blue Pixels Display Data			
TIN15	18	B3	Blue Pixels Display Data			
TIN16	19	B4	Blue Pixels Display Data			
TIN17	20	B5	Blue Pixels Display Data (MSB)			
TIN18	22	NC	Non Connection (open)	TCLK OUT- TCLK OUT+	No.11 No.12	CLK IN- CLK IN+
TIN19	23	NC	Non Connection (open)			
TIN20	25	ENAB	Compound Synchronization Signal			
CLK IN	26	NCLK	Data Sampling Clock			

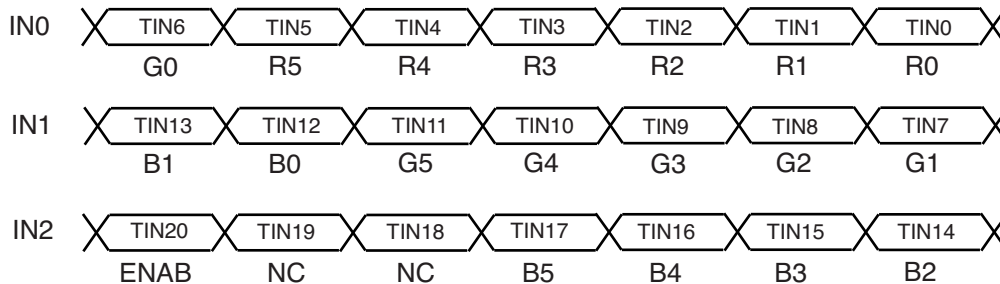

Recommended Transmitter (DS90CF383) to AND10pSi104EAS-HB Interface Assignment: 8-bit Transmitter

DS90CF383				ANDpSi10C313U		
Input Terminal No.		Input Signal (Graphics controller output signal)		Output Signal Symbol	Interface (CN1)	
Symbol	DS90CF383	Symbol	Function		Terminal	Symbol
TIN0	51	R0	Red Pixels Display Data (LSB)	TOUT0- TOUT0+	No.12 No.11	IN0- IN0+
TIN1	52	R1	Red Pixels Display Data			
TIN2	54	R2	Red Pixels Display Data			
TIN3	55	R3	Red Pixels Display Data			
TIN4	56	R4	Red Pixels Display Data			
TIN6	3	R5	Red Pixels Display Data (MSB)			
TIN7	4	G0	Green Pixels Display Data (LSB)	TOUT1- TOUT1+	No.10 No.9	IN1- IN1+
TIN8	6	G1	Green Pixels Display Data			
TIN9	7	G2	Green Pixels Display Data			
TIN12	11	G3	Green Pixels Display Data			
TIN13	12	G4	Green Pixels Display Data			
TIN14	14	G5	Green Pixels Display Data (MSB)			
TIN15	15	B0	Blue Pixels Display Data (LSB)	TOUT2- TOUT2+	No.8 No.7	IN2- IN2+
TIN18	19	B1	Blue Pixels Display Data			
TIN19	20	B2	Blue Pixels Display Data			
TIN20	22	B3	Blue Pixels Display Data			
TIN21	23	B4	Blue Pixels Display Data			
TIN22	24	B5	Blue Pixels Display Data (MSB)			
TIN24	27	NC	Non Connection (open)	TOUT3- TOUT3+	-	-
TIN25	28	NC	Non Connection (open)			
TIN26	30	ENAB	Compound Synchronization Signal			
TIN27	50	NC	Non Connection (open)			
TIN5	2	NC	Non Connection (open)			
TIN10	8	NC	Non Connection (open)			
TIN11	10	NC	Non Connection (open)	TCLK OUT- TCLK OUT+	No.6 No.5	CLK IN- CLK IN+
TIN16	16	NC	Non Connection (open)			
TIN17	18	NC	Non Connection (open)			
TIN23	25	NC	Non Connection (open)			
CLK IN	31	NCLK	Data Sampling Clock			

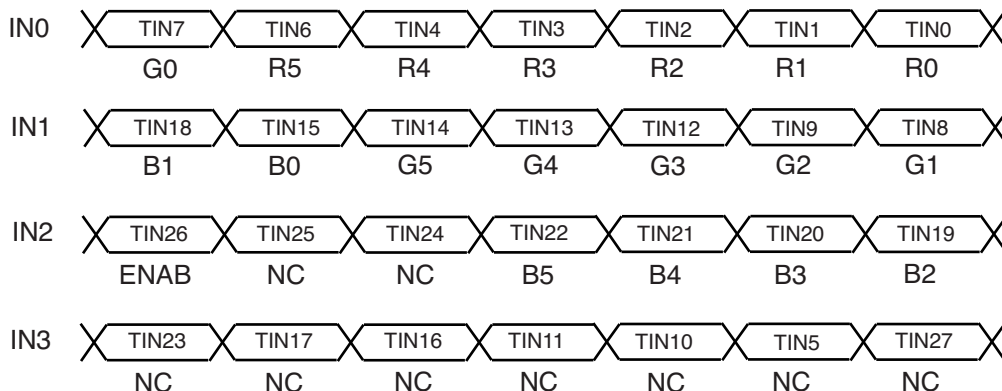

Note (2): 256K colors are displayed by the combinations of 18 data bits.

	Display	R5	R4	R3	R2	R1	R0	G5	G4	G3	G2	G1	G0	B5	B4	B3	B2	B1	B0	Gray Scale Level
Basic Color	Black	L	L	L	L	L	L	L	L	L	L	L	L	L	L	L	L	L	L	-
	Blue	L	L	L	L	L	L	L	L	L	L	L	L	H	H	H	H	H	H	-
	Green	L	L	L	L	L	L	H	H	H	H	H	H	L	L	L	L	L	L	-
	Lt. Blue	L	L	L	L	L	L	H	H	H	H	H	H	H	H	H	H	H	H	-
	Red	H	H	H	H	H	H	L	L	L	L	L	L	L	L	L	L	L	L	-
	Purple	H	H	H	H	H	H	L	L	L	L	L	L	H	H	H	H	H	H	-
	Yellow	H	H	H	H	H	H	H	H	H	H	H	H	L	L	L	L	L	L	-
	White	H	H	H	H	H	H	H	H	H	H	H	H	H	H	H	H	H	H	-
Gray Scale of Red	Black	L	L	L	L	L	L	L	L	L	L	L	L	L	L	L	L	L	L	L0
	Dark	L	L	L	L	L	H	L	L	L	L	L	L	L	L	L	L	L	L	L1
	↕	L	L	L	L	H	L	L	L	L	L	L	L	L	L	L	L	L	L	L2
		:	:	:	:	:	:	:	:	:	:	:	:	:	:	:	:	:	:	L3-L60
		:	:	:	:	:	:	:	:	:	:	:	:	:	:	:	:	:	:	L3-L60
		H	H	H	H	L	H	L	L	L	L	L	L	L	L	L	L	L	L	L61
	Light	H	H	H	H	H	L	L	L	L	L	L	L	L	L	L	L	L	L	L62
	Red	H	H	H	H	H	H	L	L	L	L	L	L	L	L	L	L	L	L	Red L63
Gray Scale of Green	Black	L	L	L	L	L	L	L	L	L	L	L	L	L	L	L	L	L	L	L0
	Dark	L	L	L	L	L	L	L	L	L	L	L	H	L	L	L	L	L	L	L1
	↕	L	L	L	L	L	L	L	L	L	L	H	L	L	L	L	L	L	L	L2
		:	:	:	:	:	:	:	:	:	:	:	:	:	:	:	:	:	:	L3-L60
		:	:	:	:	:	:	:	:	:	:	:	:	:	:	:	:	:	:	L3-L60
		L	L	L	L	L	L	H	H	H	H	L	H	L	L	L	L	L	L	L61
	Light	L	L	L	L	L	L	H	H	H	H	H	L	L	L	L	L	L	L	L62
	Green	L	L	L	L	L	L	H	H	H	H	H	H	L	L	L	L	L	L	Green L63
Gray Scale of Blue	Black	L	L	L	L	L	L	L	L	L	L	L	L	L	L	L	L	L	L	L0
	Dark	L	L	L	L	L	L	L	L	L	L	L	L	L	L	L	L	L	H	L1
	↕	L	L	L	L	L	L	L	L	L	L	L	L	L	L	L	L	H	L	L2
		:	:	:	:	:	:	:	:	:	:	:	:	:	:	:	:	:	:	L3-L60
		:	:	:	:	:	:	:	:	:	:	:	:	:	:	:	:	:	:	L3-L60
		L	L	L	L	L	L	L	L	L	L	L	L	H	H	H	H	L	H	L61
	Light	L	L	L	L	L	L	L	L	L	L	L	L	H	H	H	H	H	L	L62
	Blue	L	L	L	L	L	L	L	L	L	L	L	L	H	H	H	H	H	H	Blue L63
Gray Scale of White & Black	Black	L	L	L	L	L	L	L	L	L	L	L	L	L	L	L	L	L	L	L0
	Dark	L	L	L	L	L	H	L	L	L	L	L	H	L	L	L	L	L	H	L1
	↕	L	L	L	L	H	L	L	L	L	L	H	L	L	L	L	L	H	L	L2
		:	:	:	:	:	:	:	:	:	:	:	:	:	:	:	:	:	:	L3-L60
		:	:	:	:	:	:	:	:	:	:	:	:	:	:	:	:	:	:	L3-L60
		H	H	H	H	L	H	H	H	H	H	L	H	H	H	H	H	L	H	L61
	Light	H	H	H	H	H	L	H	H	H	H	H	L	H	H	H	H	H	L	L62
	White	H	H	H	H	H	H	H	H	H	H	H	H	H	H	H	H	H	H	White L63

INV-CLIO-12-U-002 Inverter

This is a DC-AC Inverter to drive Cold Cathode Fluorescent Lamp. The INV-CLIO-12-U-002 is a 3 CCFL Inverter Module specifically designed for driving 10.4" ANDpSi104EA5S-4HB display. This inverter is available with a dimming function that permits brightness control from a DC voltage source or external Potentiometer. The maximum output current is externally regulated or programmable over a range of 6 to 7.5 mA. The Digital Dimming Technique provides flicker-free brightness control in PWM Duty Cycle from 1.0% to 99% dimming application. The module design is based on Embedded programs so that the module provides low cost and high performance. This inverter supports fixed frequency operation, soft-start, anti-interference capability, open/shorted lamp protection with Watch-Dog timeout.

Appearance: General Tolerance: $\pm 0.3\text{mm}$

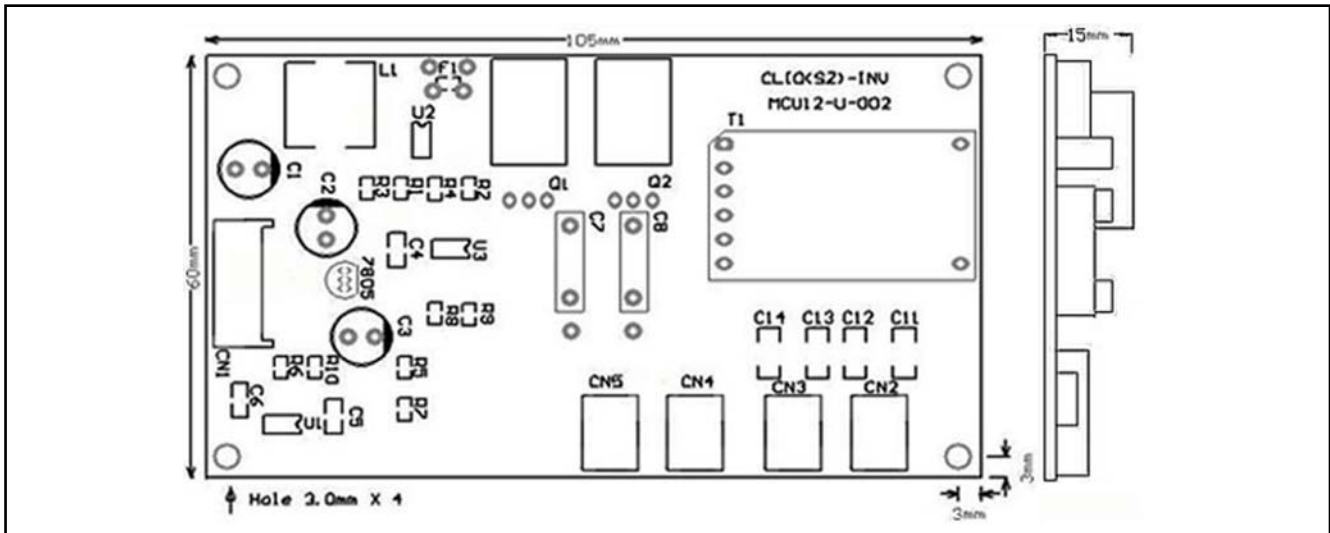

Dimension: L * W * H = 105mm (typ) * 60mm (typ) * 15.0mm (max)

Absolute Maximum Rating

Item	Ratings	Item	Ratings
Voltage (V_{in})	$12V \pm 10\%$	Output Power (each output)	$3.0W \pm 5\%$
Input Current (U Lamps)	$4W \pm 5\%$	Ambient Operating Temperature	-40° to $+85^\circ$
Output Voltage, no load	1400 Vrms	Operating Relative Humidity	$\leq 90\%$
Output Current	7.5 mArms (Internally Limited)	Storage Temperature Range	-40° to $+85^\circ$

Recommended Operating Conditions (for 2 x 98mm + 21mm U type CCFL)

Item	Symbol	Min	Typ	Max	Unit
Input Supply Voltage	V_{in}	10.8	12.0	13.2	V
Output Power (each output)	P_o	3.5	3.8	4.0	W
Dim Control Input Voltage Range	$V_{dimCtrl}$	0.5	-	5.0	V
Lamp Operating Voltage	V_{lamp}	375	396	430	Vrms
Lamp Current (Full Brightness)	I_{olamp}	6.5	7.0	7.5	mArms

Electrical Characteristics

Item	Symbol	Test Conditions	Min.	Typ.	Max.	Units
Full Bright Lamp Current	IMAX	VDimCtrl = 5V	5.5	7.0	8.5	mArms
Output Current Lamp to Lamp Deviation	-	-	-	3 %	10%	-
Min. Average Lamp Current (each output)	IMIN	VDimCtrl - 0.05V	-	0.07	-	mArms
Lamp Start Voltage	-	Vin > 11.5V	460	535	-	Vrms
Operating Frequency	-	VDimCtrl = 5V	53.5	52	49	KHz
Burst Frequency	-	-	67	70	72	Hz
Efficiency	-	-	86%	90%	93%	-

Functional Pin Description - CN1 Landwin2003P07SOT

Item	Symbol	Remarks
CN1-3	+ 5V Output	Supply +5V power for external Potentiometer
CN1-2	Enable	On/Off Control
CN1-1	Dim Control	Brightness Control %VDC gives maximum lamp current
CN1-4, 5	GND	Power Supply Return
CN1-6, 7	Vin	Main Input Power Supply (11.4V < Vin < 12.6V)

Functional Pin Description - CN2, 3 Landwin3502P0210T SMT

Item	Symbol	Remarks
CN2-1, 2	VHI	High voltage connection to high side of lamp 1, lamp 2
CN3-1	VHI	High voltage connection to high side of lamp 3

Functional Pin Description - CN4, CN5 Landwin3502P0210T SMT

Item	Symbol	Remarks
CN4-1, 2	VOL	Connection to low side of lamp 1, 2, 3

Test Circuit

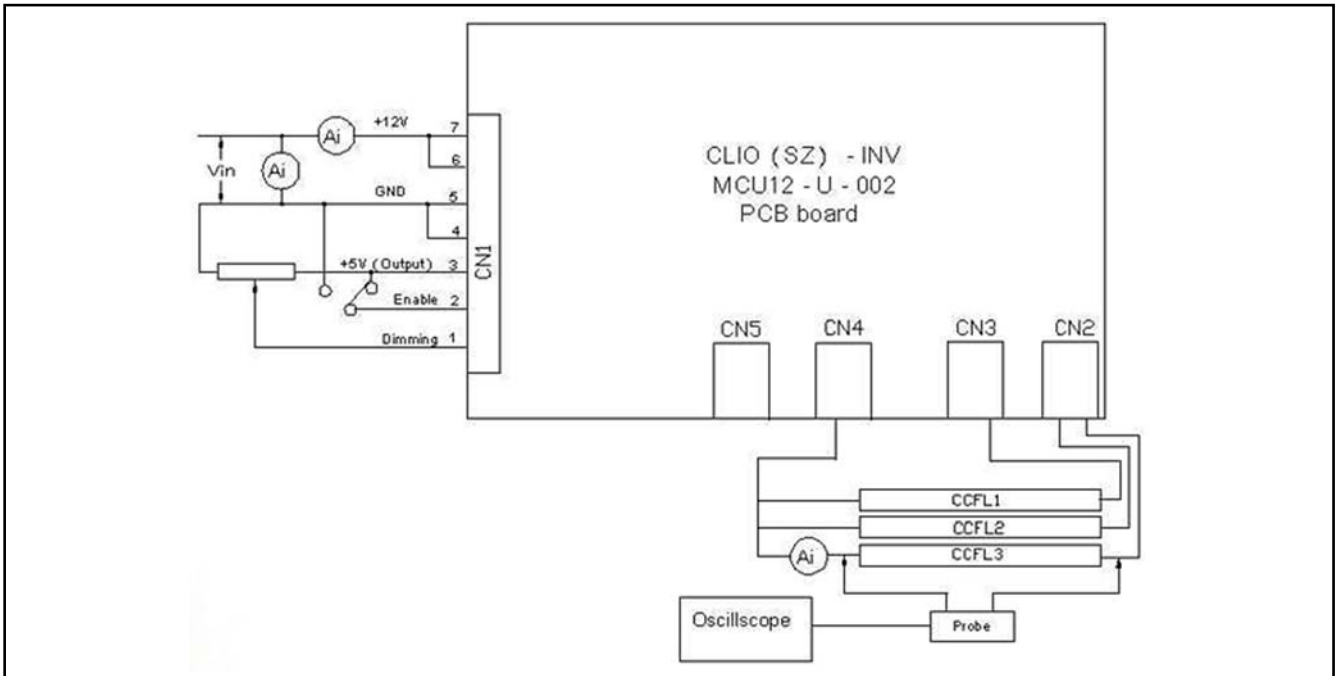

Connect Diagram

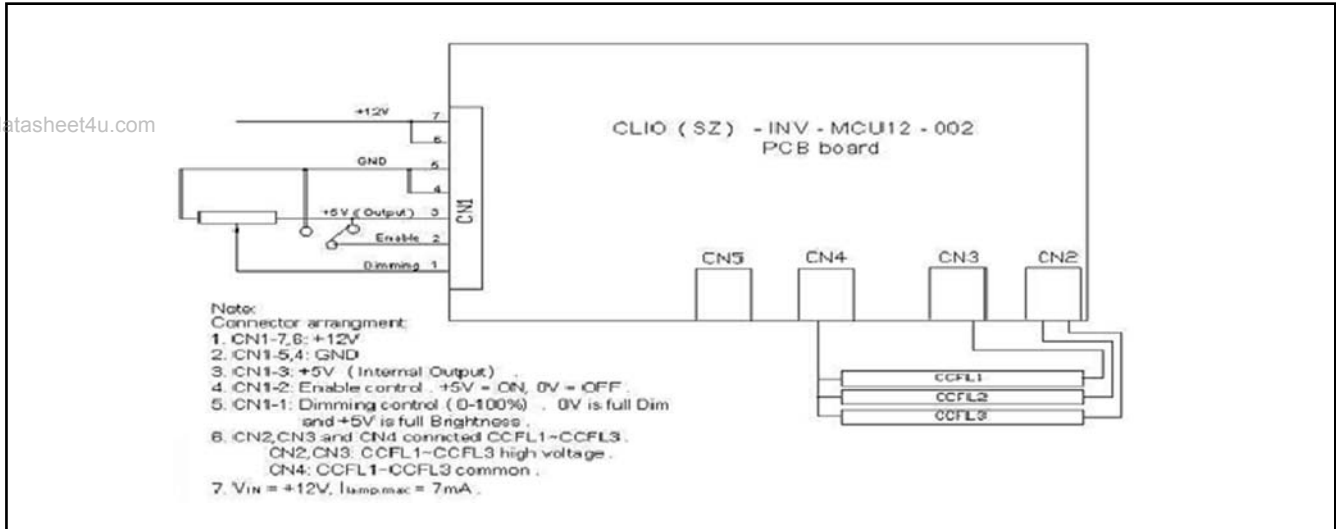

Block Diagram

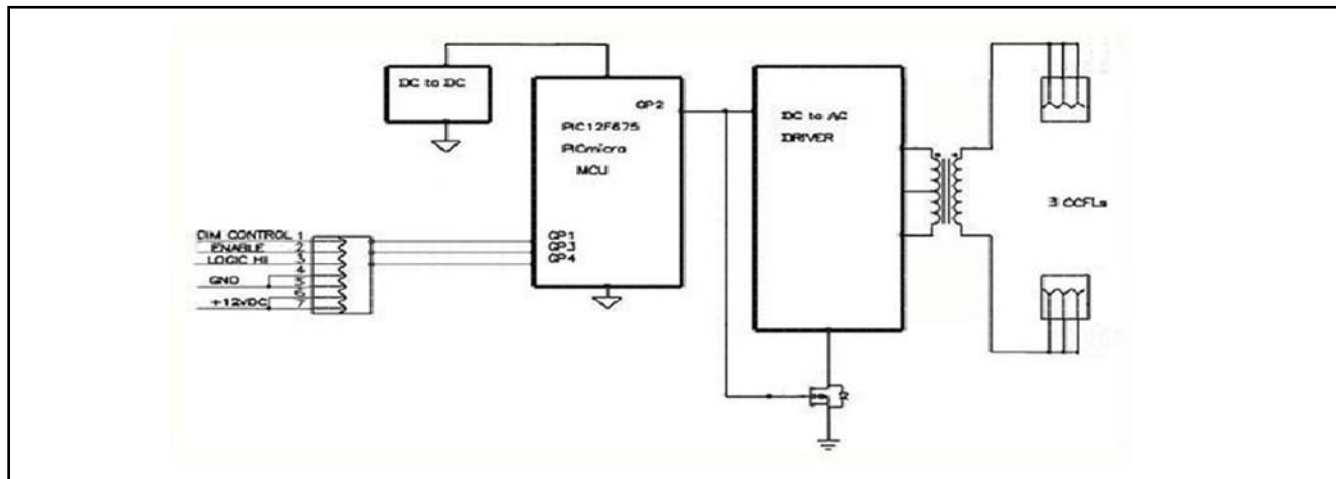

Print Curcuit Board Diagram

