



Monolithic ICs

T-52-13-25



T-77-21

• VTR Motor Drivers (continued)

Type	Function	Package		Features	Reference Catalog
		Configuration	No. of pins		
BA6209/BA6209N/BA6209FP	Reversible motor driver	SIP-P/ SIP/MFP	10/10/24	Built-in motor drive power transistors. Built-in motor stopping brake function. 1.6A drive capability.	No.3121
BA6219B/BA6219BFP	Reversible motor driver	SIP-P/ MFP	10/24	Built-in motor drive power transistors. Built-in motor brake function. 2.2A drive capability.	No.3121
BA6222	Reversible motor driver	SIP-P	10	Built-in motor drive power transistors. Built-in motor stopping brake function. 2.2A drive capability. Built-in control input amplifier.	No.3121
BA6229	Reversible motor driver	SIP-P	10	Built-in motor drive power transistors. Automatic control for normal rotation, reverse rotation, brake and stop of operation. 1.2A drive.	No.3121
BA6418N	Reversible motor drive	SIP	9	Built-in motor drive power transistors for 4 drive control modes: forward, reverse, brake, and stop; 0.7A drive capability.	No.3121
BA6238A/BA6238AN	2-ch Reversible motor driver	SIP-P/ SIP	10	2 built-in motor drive power transistors. 3-input, 5-mode selection logic. 1.6A drive capability.	No.3121
BA6239A/BA6239AN	2-ch Reversible motor driver	SIP-P/ SIP	10	2 built-in motor drive power transistors. 3-input, 5-mode selection logic. 1.2A drive capability.	No.3121
BA6246/BA6246N	2-ch Reversible motor driver	SIP-P/ SIP	10	2 built-in motor drive power transistors. 3-input, 6-mode selection logic. 1.0A drive capability.	No.3121
BA6247/BA6247N	2-ch Reversible motor driver	SIP-P/ SIP	10	2 built-in motor drive power transistors. 3-input, 5-mode selection logic. 1.0A drive capability.	No.3121
BA6248	2-ch Reversible motor driver	SIP-P/ SIP	10	2 built-in motor drive power transistors. 3-input, 5-mode selection logic. 1.6A drive capability.	—
BA6249/BA6249N	2-ch Reversible motor driver	SIP-P/ SIP	10	2 built-in motor drive power transistors. 3-input, 6-mode selection logic.	No.3121
BA6259N	2-ch Reversible motor driver	SIP	10	1.0A drive capability.	No.3121
BA6411	2-phase DD motor driver	SIP-P	12	2-phase, all-wave motor driver; low switching noise due to linear drive; includes constant voltage terminal for Hall element power supply; built-in forward/reverse switching function.	No.3121
BA6413	2-phase DD motor driver	SIP-P	12	2-phase, all-wave motor driver; low switching noise due to linear drive; independent Hall element power supply; built-in forward/reverse switching function; 1.2A drive.	No.3121
BA6414FS/BA6414FP	2-phase DD motor driver	MFS/MFP	24	2-phase, all-wave motor driver; low switching noise includes constant voltage terminal for Hall element power supply, built-in hysteresis amp.	—
BA6432S	3-phase DD motor driver	DIPS-P	24	High-performance motor driver compatible with switching regulators, contains a pseudo-linear type ripple cancelling circuit.	No.3121
BA6431F	3-phase DD motor driver	MF	28		No.3121
BA6435S	3-phase DD motor driver	DIPS-P-F	24	High-performance motor drivers compatible with switching regulators, containing a pseudo-linear ripple canceling circuit; internal output transistor anti-saturation circuit	No.3121
BA6436P	3-phase DD motor driver	DIPS-P	24		No.3121
BA6453FP	3-phase DD motor driver	MFP	24	Pseudo linear system; built-in amplifier and hysteresis amp.	—
BA6455FS	3-phase DD motor driver	MFS	24	3-phase, all-wave motor driver; with torque limiting input terminal; with switching regulator function.	No.3121
BA6456P	3-phase DD motor driver	DIPS-P	24	3-phase, all-wave motor drivers compatible with switching regulators: With 2 amplifier circuits.	—
BA6456FS	3-phase DD motor driver	MFS	24		No.3121
BA6457P	3-phase DD motor driver	DIPS-P	24	Pseudo linear system; built-in amplifier and hysteresis amp.	—
BA6458FP	3-phase DD motor driver	MFP	24	Pseudo linear system; built-in amplifier and hysteresis amp.	—
BA6459P/BA6459S	3-phase DD motor driver	DIPS-P/ P-F	24	3-phase, all-wave motor drivers compatible with switching regulators: With 2 amplifier circuits.	No.3121
BA6459FS	3-phase DD motor driver	MFS	24		
BA6462FS/BA6462FP	3-phase DD motor driver	MFS/MFP	24	Three-phase, pseudo-linear motor driver	—

Note: Some of the MF packages need a lead time for delivery. Please confirm with us before ordering.

Package symbol legend

SIP : Single-in-line package
DIP : Dual-in-line package
MF : Mini-flat package (SOP)
LF : Zig-Zag-in-line package (ZIP)
QFP : Quad flat package
MFS : MF shrink package
MFP : Power shrink MF package
DIPS : Shrink DIP package
-P : Power version
-F : Fin version



Dimensions (Unless otherwise specified, dimensions are shown in Typ. values.)

SIP

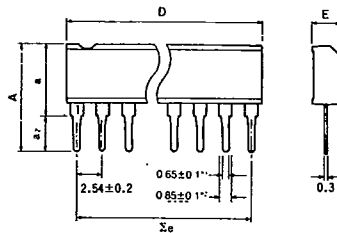

• SIP Dimensions (Unit: mm)

Package	A	a	a ₂	D	Σe	E
SIP 5	9.7	6.2	3.5	12.0	10.16	2.4
SIP 7	9.7	6.2	3.5	17.0	15.24	2.8
SIP 8	10.5	7.0	3.5	19.5	17.78	2.8
SIP 9	10.5	7.0	3.5	22.0	20.32	2.8
SIP 10	10.5	7.0	3.5	25.2	22.86	2.8

*1 SIP 10pin: 0.6 *2 SIP 10pin: 0.8

DIP/DIPS

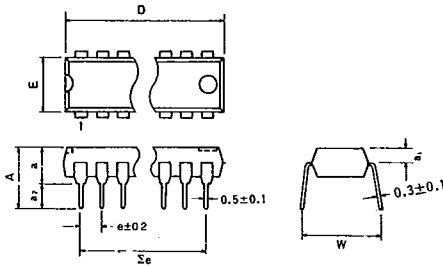

• DIP Dimensions (Unit: mm)

Package	A	a	a ₁	a ₂	D	e	Σe	E	W
DIP 8	6.8	3.6	1.1	3.2	9.3	2.54	7.62	6.5	8.8
DIP 14	6.94	3.65	1.65	3.29	19.4	2.54	15.24	6.5	8.8
DIP 16	6.94	3.65	1.65	3.29	19.4	2.54	17.78	6.5	8.8
DIP 18	6.94	3.65	1.65	3.29	22.9	2.54	20.32	6.5	8.8
DIP 20	7.09	3.65	1.65	3.44	26.3	2.54	22.86	6.5	8.8
DIP 22	7.09	3.65	1.65	3.44	26.3	2.54	25.40	6.5	8.8
DIP 24	7.51	4.22	1.8	3.29	32.0	2.54	27.94	13.8	16.5
DIP 28	7.51	4.22	1.8	3.29	37.1	2.54	33.02	13.8	16.5
DIP 40	7.7	4.5	1.8	3.2	52.3	2.54	48.26	13.8	16.5
DIPS 18	7.35	3.65	1.65	3.7	19.4	1.778	14.224	6.5	8.8
DIPS 22	7.35	3.65	1.65	3.7	19.4	1.778	17.78	6.5	8.8
DIPS 24	7.4	4.0	1.7	3.4	22.8	1.778	19.558	6.5	8.8
DIPS 30	7.9	4.7	1.7	3.2	28.0	1.778	24.892	8.4	11.4
DIPS 32	7.9	4.7	1.7	3.2	28.0	1.778	26.67	8.4	11.4
DIPS 42	7.7	4.5	1.8	3.2	37.1	1.778	35.56	13.8	16.5

MF/MFS/MFP

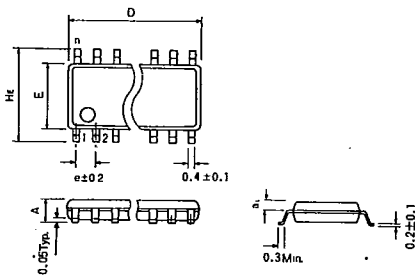

• MF Dimensions (Unit: mm)

Package	A	a ₁	D	H _E	e	E
MF 8	1.5	0.65	5.0	6.2	1.27	4.4
MF 14	1.5	0.65	8.7	6.2	1.27	4.4
MF 16	1.5	0.65	10.0	6.2	1.27	4.4
MF 18	1.8	0.8	11.2	7.8	1.27	5.4
MF 20	1.8	0.8	12.5	7.8	1.27	5.4
MF 22	1.8	0.8	13.7	7.8	1.27	5.4
MF 24	1.8	0.8	15.0	7.8	1.27	5.4
MF 28	2.2	1.0	18.5	9.9	1.27	7.5
MFS 16	1.5	0.65	6.6	6.2	0.8	4.4
MFS 20	1.8	0.8	8.7	7.8	0.8	5.4
MFS 24	1.8	0.8	10.0	7.8	0.8	5.4
MFP 24	1.9	0.8	13.7	7.8	0.8	5.4
MFP 28	2.2	0.95	18.5	9.9	0.8	7.5

LF/LFS

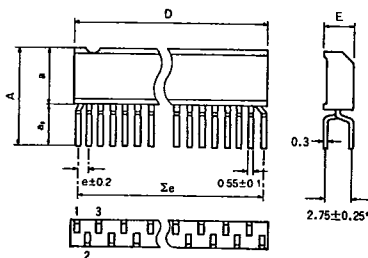

• LF Dimensions (Unit: mm)

Package	A	a	a ₂	D	Σe	e	E
LF 9	9.8	5.0	4.8	12.0	10.16	1.27	2.4
LF 12	9.8	5.0	4.8	17.0	13.97	1.27	2.8
LF 16	9.9	5.8	4.1	19.5	19.05	1.27	2.8
LF 18	9.9	5.8	4.1	22.0	21.59	1.27	2.8
LFS 24	10.0	5.8	4.2	22.0	20.447	0.889	2.8

*LFS 24: 2.54±0.25



Monolithic ICs



T-90-20

QFP/QFPS

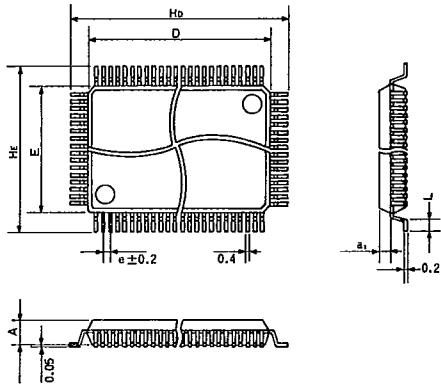

• QFP Dimensions (Unit: mm)

Package	A	a ₁	D	e	E	H _E	H _D	L
QFP 32	1.45	0.65	7.0	0.8	7.0	9.0	9.0	0.4
QFP 44	2.15	1.0	10.0	0.8	10.0	14.0	14.0	1.2
QFP 64	2.15	1.0	20.0	1.0	14.0	18.0	24.0	1.2
QFP 80	2.7	1.275	20.0	0.8	14.0	18.0	24.0	1.2
QFPS 56	2.15	1.0	10.0	0.65	10.0	12.4	12.4	0.5
QFPS 80	2.7	1.275	14.0	0.65	14.0	16.4	16.4	0.5
QFPS 100	2.7	1.275	20.0	0.65	14.0	18.0	24.0	1.2

SIP-P 10 pin

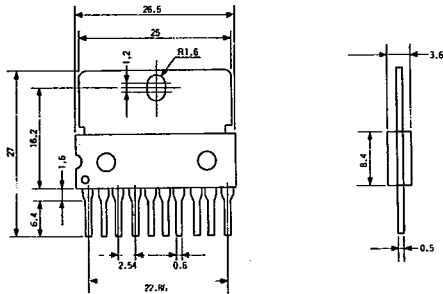

SIP-P 12 pin

