



# 74LVCZ161284A

## LOW VOLTAGE HIGH SPEED IEEE1284 TRANSCEIVER WITH ERROR-FREE POWER-UP

- HIGH SPEED:  $t_{PD} = 9ns$  (MAX.) at  $V_{CC} = 3V$
- LOW POWER DISSIPATION:  
 $I_{CC}=20\mu A$  (MAX) at  $V_{CC}=3.6V$   $T_A=85^\circ C$
- TTL COMPATIBLE INPUTS  
 $V_{IH}=2V$  (MIN)  $V_{IL}=0.8$ (MAX)
- OPERATING VOLTAGE RANGE:  
 $V_{CC}(OPR) = 3.0V$  to  $3.6V$
- A PORT HAVE STANDARD 4mA TOTEM POLE OUTPUT
- B PORT HIGH DRIVE SOURCE/SINK CAPABILITY OF 14mA
- AUTO POWER-UP FEATURE TO PREVENT PRINTER ERRORS
- SUPPORT IEEE STD 1284-I (LEVEL 1 TYPE) AND IEEE STD 1284-II (LEVEL 2 TYPE) FOR BIDIRECTIONAL PARALLEL COMMUNICATIONS BETWEEN PERSONAL COMPUTER ANT PRINTING PERIPHERALS
- TRANSLATION CAPABILITY ALLOW OUTPUTS ON CABLE SIDE TO INTERFACE WITH 5V SIGNAL
- PULL-UP RESISTOR INTEGRATED ON ALL OPEN-DRAIN OUTPUT ELIMINATE THE NEED FOR DISCRETE RESISTOR
- REPLACE THE FUNCTION OF TWO 74LVC1284 DEVICES

### DESCRIPTION

The 74LVCZ161284A contains eight high speed non inverting bidirectional buffers and eleven control/status non-inverting buffers with open drain outputs fabricated in silicon gate C<sup>2</sup>MOS technology. It's intended to provide a standard signaling method for a bi-direction parallel peripheral in an Extended Capabilities Port Mode (ECP). The HD (Active HIGH) input pin enables the Cable port to switch from Open Drain to a high drive totem pole output, capable of sourcing 14mA on all thirteen buffer and 84mA on PERI LOGIC OUTPUT buffer. The DIR input determines the direction of data flow on the bidirectional buffers. DIR (Active HIGH) enables data flow from A port to B port. DIR (Active LOW) enables data flow from B port to A port. The Y output (Y9-Y13) stay in the high state after power-on until an associated input A9-A13) goes high. When an associated input goes high, all Y outputs are active, and non

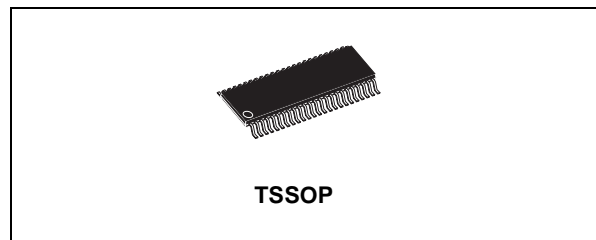

### ORDER CODES

PACKAGE	TUBE	T & R
TSSOP		74LVCZ161284ATTR

### PIN CONNECTION

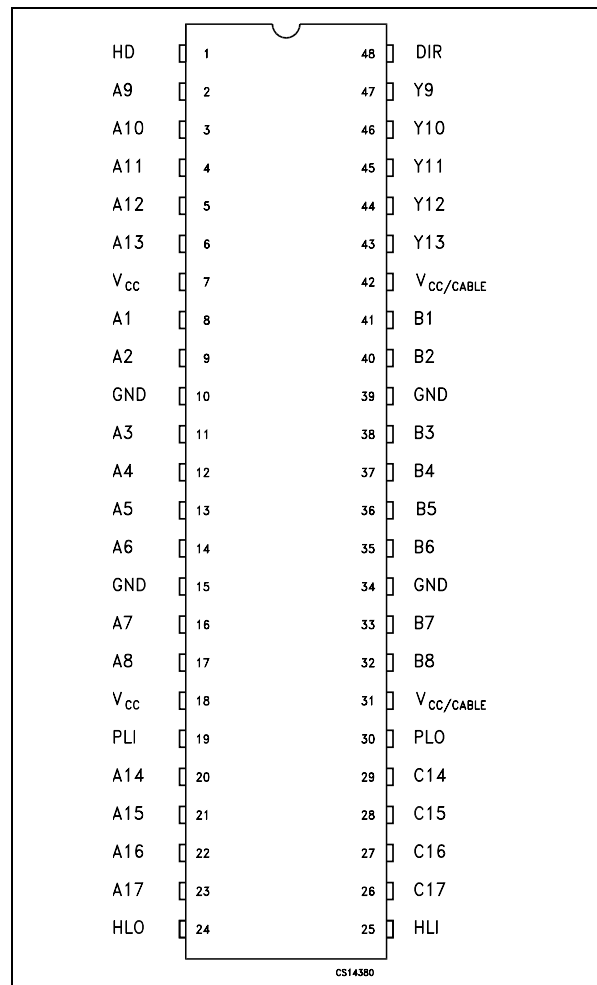

# 74LVCZ161284A

inverting signals of the associated inputs are driven through Y outputs. This special feature prevents printer system errors caused by deasserting the BUSY signal in the cable at

power-on. It is available in the commercial temperature range.

## LOGIC DIAGRAM

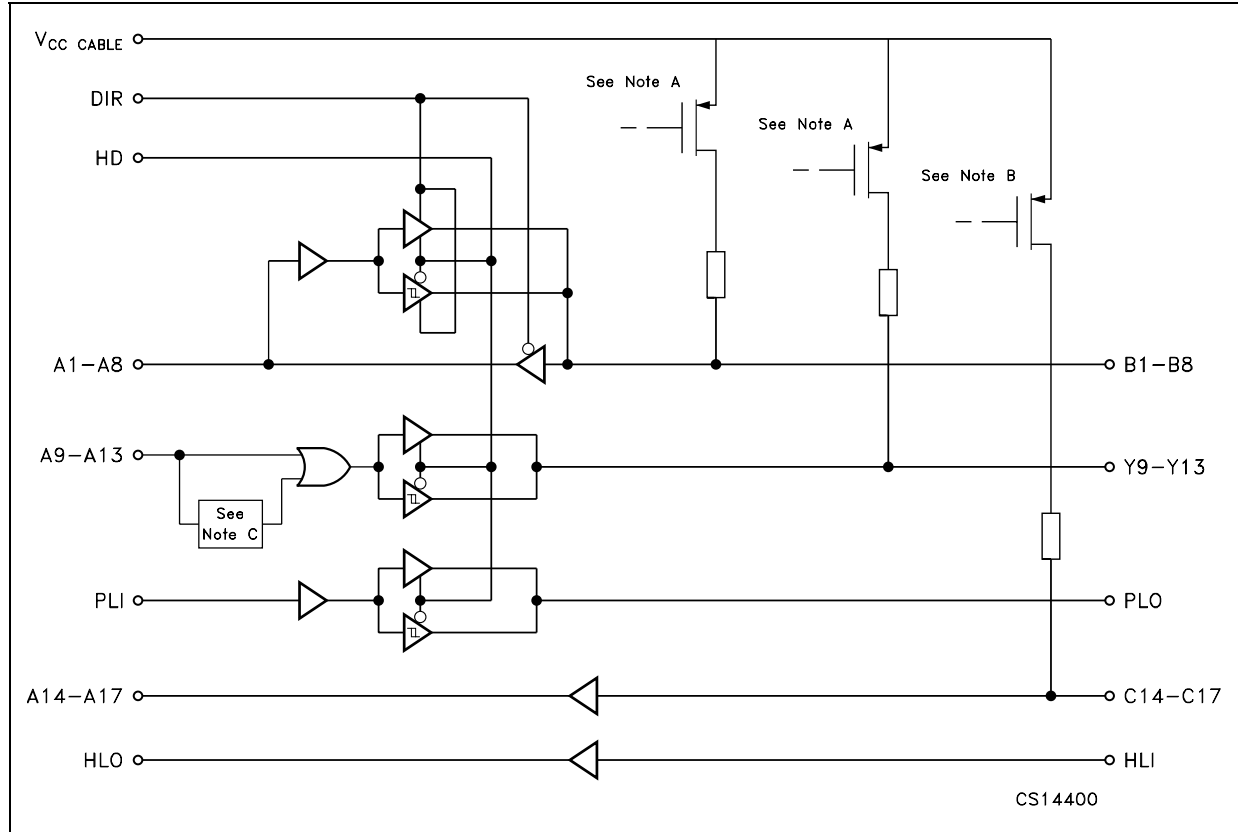

- NOTE A: The PMOS transistors prevent backdriving current from the signal pins to  $V_{CC/CABLE}$  when  $V_{CC/CABLE}$  is open or at GND. The PMOS transistor is turned off when the associated driver is in the low state.
- NOTE B: The PMOS transistor prevents backdriving current from the signal pins to  $V_{CC/CABLE}$  when  $V_{CC/CABLE}$  is open or at GND.
- NOTE C: Active input detection circuit forces Y9-Y13 to the low state after power-on until one of the A9-A13 goes high. See below.

## ACTIVE INPUT DETECTION CIRCUIT

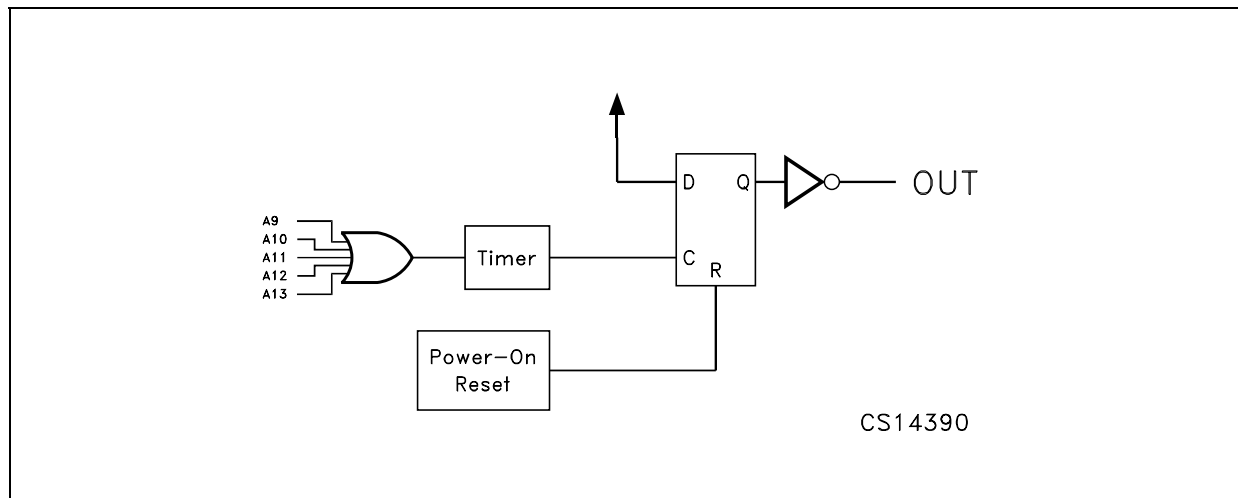

## PIN DESCRIPTION

PIN N°	SYMBOL	NAME AND FUNCTION
1	HD	High Drive Enable Input
2, 3, 4, 5, 6	A9 to A13	Side A Input
8, 9, 11, 12, 13, 14, 16, 17	A1 to A8	Side A Input or Output
19	PLI	Peripheral Logic Input
20, 21, 22, 23	A14 to A17	Side A Output
24	HLO	Host Logic Output
25	HLI	Host Logic Input
29, 28, 27, 26	C14 to C17	Side Cable Output
30	PLO	Peripheral Logic Output
41, 40, 38, 37, 36, 35, 33, 32	B1 to B8	Side Cable Input or Output
47, 46, 45, 44, 43	Y9 to Y13	Side Cable Output
48	DIR	Direction Control Input
10, 15, 34, 39	GND	Ground (0V)
7, 18	V <sub>CC</sub>	Positive Supply Voltage
31, 42	V <sub>CC/CABLE</sub>	Cable Power Supply

## TRUTH TABLE

INPUT		OUTPUT	OUTPUT
DIR	HD		
L	L	B1-B8 Data to A1-A8 A9-A13 Data to Y9-Y13 C14-C17 Data to A14-A17	Y9-Y13 and PLO Open Drain
L	H		Y9-Y13 and PLO Totem Pole
H	L	A1-A8 Data to B1-B8 A9-A13 Data to Y9-Y13 C14-C17 Data to A14-A17	B1-B8 Y9-Y13 and PLO Open Drain
H	H		B1-B8 Y9-Y13 and PLO Totem Pole

## ABSOLUTE MAXIMUM RATINGS

Symbol	Parameter	Value	Unit	
$V_{CC}$	Supply Voltage	-0.5 to +4.6	V	
$V_{CCcable}$	Cable Supply Voltage (must be $\geq V_{CC}$ )	-0.5 to +7.0	V	
$V_{IA}$	DC Input Voltage A1-A13, $PL_{IN}$ , DIR, $HD_{IN}$	-0.5 to $+V_{CC} + 0.5$	V	
$V_{IB}$	DC Input Voltage B1-B8, C14-C17, $HL_{IN}$	-0.5 to +5.5	V	
$V_{IBp}$	DC Input Voltage B1-B8, C14-C17, $HL_{IN}$ (40ns transient)	-2 to +7	V	
$V_{OA}$	DC Output Voltage A1-A8, A14-A17, $HL_{IN}$	-0.5 to $+V_{CC} + 0.5$	V	
$V_{OB}$	DC Output Voltage B1-B8, Y9-Y13, $PL_{IN}$	-0.5 to +5.5	V	
$V_{OBp}$	DC Output Voltage B1-B8, Y9-Y13, $PL_{IN}$ (40ns transient)	-2 to +7	V	
$I_{IK}$	DC Input Diode Current DIR, HD A9-A13, $PL_{IN}$ C14-C17	- 20	mA	
$I_{OK}$	DC Output Diode Current	A1-A8, A14-A17, $HL_{IN}$	$\pm 50$	mA
		B1-B8, Y9-Y13, $PL_{IN}$	- 50	
$I_O$	DC Output Current	A1-A8, $HL_{IN}$	$\pm 25$	mA
		B1-B8, Y9-Y13	$\pm 50$	
		$PL_O = LOW$	84	
		$PL_O = HIGH$	-50	
$I_{CC}$ or $I_{GND}$	DC $V_{CC}$ or Ground Current per Supply Pin	$\pm 200$	mA	
$T_{stg}$	Storage Temperature	-65 to +150	$^{\circ}C$	
$T_L$	Lead Temperature (10 sec)	300	$^{\circ}C$	

Absolute Maximum Rating are those value beyond which damage to the device may occur. Functional operation under these condition is not implied

## RECOMMENDED OPERATING CONDITIONS

Symbol	Parameter	Value	Unit
$V_{CC}$	Supply Voltage	3.0 to 3.6	V
$V_{CCcable}$	Cable Supply Voltage	3.0 to 5.5	V
$V_I$	Input Voltage	0 to $V_{CC}$	V
$V_O$	Open Drain Output Voltage	0 to 5.5	V
$T_{op}$	Operating Temperature	-40 to 85	$^{\circ}C$

## DC SPECIFICATIONS

Symbol	Parameter		Test Condition			Value		Unit
			V <sub>CC</sub> (V)	V <sub>CCcable</sub> (V)		-40 to 85 °C		
						Min.	Max.	
V <sub>IH</sub>	High Level Input Voltage	An, Bn, PL <sub>IN</sub> , DIR, HD	3.0 to 3.6	3.0 to 5.5		2		V
		Cn				2.3		
		HL <sub>IN</sub>				2.6		
V <sub>IL</sub>	Low Level Input Voltage	An, Bn, PL <sub>IN</sub> , DIR, HD	3.0 to 3.6	3.0 to 5.5			0.8	V
		Cn					0.8	
		HL <sub>IN</sub>					1.6	
V <sub>OH</sub>	High Level Output Voltage	An, HL	3.0	3.0	I <sub>O</sub> =-50μA	2.8		V
			3.0	3.0	I <sub>O</sub> =-4mA	2.4		
		Bn, Yn	3.0	3.0	I <sub>O</sub> =-14mA	2.0		
		Bn, Yn	3.0	4.5	I <sub>O</sub> =-14mA	2.23		
		PL	3.15	3.15	I <sub>O</sub> =-500μA	3.1		
V <sub>OL</sub>	Low Level Output Voltage	An, HL	3.0	3.0	I <sub>O</sub> =50μA		0.2	V
			3.0	3.0	I <sub>O</sub> =4mA		0.4	
		Bn, Yn	3.0	3.0	I <sub>O</sub> =14mA		0.8	
		Bn, Yn	3.0	4.5	I <sub>O</sub> =14mA		0.77	
		PL	3.0	3.0	I <sub>O</sub> =84mA		0.95	
		PL	3.0	4.5	I <sub>O</sub> =84mA		0.90	
I <sub>I</sub>	Input Current	Cn	3.6	3.6	V <sub>I</sub> = V <sub>CC</sub>		50	μA
			3.6	3.6	V <sub>I</sub> =GND (Pull-up res)		-3.5	mA
		All input except B or C	3.6	5.0	V <sub>I</sub> = V <sub>CC</sub> or GND		± 1	μA
I <sub>CC</sub>	Quiescent Supply Current		3.6	5.0	V <sub>I</sub> = V <sub>CC</sub> I <sub>O</sub> =0		0.8	mA
					V <sub>I</sub> =GND (12xPull-up)		45	
I <sub>OZ</sub>	High Impedance Output Leakage Current	Bn	3.6	5.0	V <sub>O</sub> = V <sub>CC</sub>		20	μA
			3.6	3.6	V <sub>O</sub> =GND (Pull-up res)		-3.5	mA
		A1-A8	3.6	5.0	V <sub>O</sub> = V <sub>CC</sub> or GND		± 20	μA
		Open Drain Y Output	3.6	3.6	V <sub>O</sub> =GND (Pull-up res)		-3.5	mA
I <sub>OFF</sub>	Power Off Leakage Current	B, Y output (to GND)	0	5.0	V <sub>I</sub> or V <sub>O</sub> = 0 to 7V		100	μA
		B, Y output (to V <sub>CC</sub> )	0	5.0	V <sub>I</sub> or V <sub>O</sub> = 0 to 7V		10	μA
V <sub>hys</sub>	Input Hysteresis	An, Bn, PL <sub>IN</sub> , DIR, HD	3.3	5.0		0.4		V
		Cn	3.3	5.0		0.8		
		HL <sub>IN</sub>	3.3	5.0		0.2		
Z <sub>O</sub>	Output Impedance	B1-B8, Y9-Y13	3.3	5.0	V <sub>B</sub> = V <sub>OH</sub>	30	55	Ω
R <sub>P</sub>	Pull-up Resistance	B1-B8, Y9-Y13, C14-C17	3.3	5.0	V <sub>B</sub> = V <sub>OH</sub>	1150	1650	Ω

## AC ELECTRICAL CHARACTERISTICS

Symbol	Parameter		Test Condition			Value		Unit
			V <sub>CC</sub> (V)	V <sub>CCcable</sub> (V)		-40 to 85 °C		
						Min.	Max.	
t <sub>PLH</sub> t <sub>PHL</sub>	Propagation Delay Time	A1-A8 to B1-B8, A9-A13 to Y9-Y13	3.0 to 3.6	3.0 to 5.5	R <sub>L</sub> =500Ω C <sub>L</sub> =50pF	1	7.5	ns
		B1-B8 to A1-A8, C14-C17 to A14-A17			R <sub>L</sub> =500Ω C <sub>L</sub> =50pF	1	9.0	ns
		PL <sub>IN</sub> to PL <sub>OUT</sub>			R <sub>L</sub> =500Ω C <sub>L</sub> =50pF	1	7.0	ns
		HL <sub>IN</sub> to HL <sub>OUT</sub>			R <sub>L</sub> =500Ω C <sub>L</sub> =50pF	1	11.0	ns
t <sub>PZH</sub> t <sub>PZL</sub>	Enable Delay Time	DIR to A	3.0 to 3.6	3.0 to 5.5	R <sub>L</sub> =500Ω C <sub>L</sub> =50pF	1	12	ns
		HD to Bn, Y9-Y13	R <sub>L</sub> =500Ω C <sub>L</sub> =50pF	1	8.5	ns		
t <sub>PLZ</sub> t <sub>PHZ</sub>	Disable Delay Time	DIR to A	3.0 to 3.6	3.0 to 5.5	R <sub>L</sub> =500Ω C <sub>L</sub> =50pF	1	8.5	ns
		DIR to A	R <sub>L</sub> =500Ω C <sub>L</sub> =50pF	1	8.5	ns		
		HD to Bn, Y9-Y13	R <sub>L</sub> =500Ω C <sub>L</sub> =50pF	1	8.5	ns		
t <sub>r</sub> t <sub>f</sub>	Rise and Fall Time B1-B8, Y9-Y13 Open Drain		3.0 to 3.6	3.0 to 5.5	R <sub>L</sub> =500Ω C <sub>L</sub> =50pF	1	120	ns
t <sub>OSLH</sub> t <sub>OSHL</sub>	Output To Output Skew Time (note1, 2)		3.0 to 3.6	3.0 to 5.5	R <sub>PULL-UP</sub> =500Ω C <sub>L</sub> =50pF	1	2	ns

1) Skew is defined as the absolute value of the difference between the actual propagation delay for any two outputs of the same device switching in the same direction, either HIGH or LOW ( $t_{OSLH} = |t_{PLHm} - t_{PLHn}|$ ,  $t_{OSHL} = |t_{PHLm} - t_{PHLn}|$ )

2) Parameter guaranteed by design

## CAPACITANCE CHARACTERISTICS

Symbol	Parameter	Test Condition		Value			Unit
		V <sub>CC</sub> (V)	V <sub>CC/CABLE</sub> (V)	T <sub>A</sub> = 25 °C			
				Min.	Typ.	Max.	
C <sub>IN</sub>	Control Input Capacitance (HD, DIR, A9-A13, C14-C17, PL <sub>IN</sub> , HL <sub>IN</sub> )	Open	Open		4		pF
C <sub>I/O</sub>	I/O Pin Capacitance	3.3	5.0		6		pF

TEST CIRCUIT

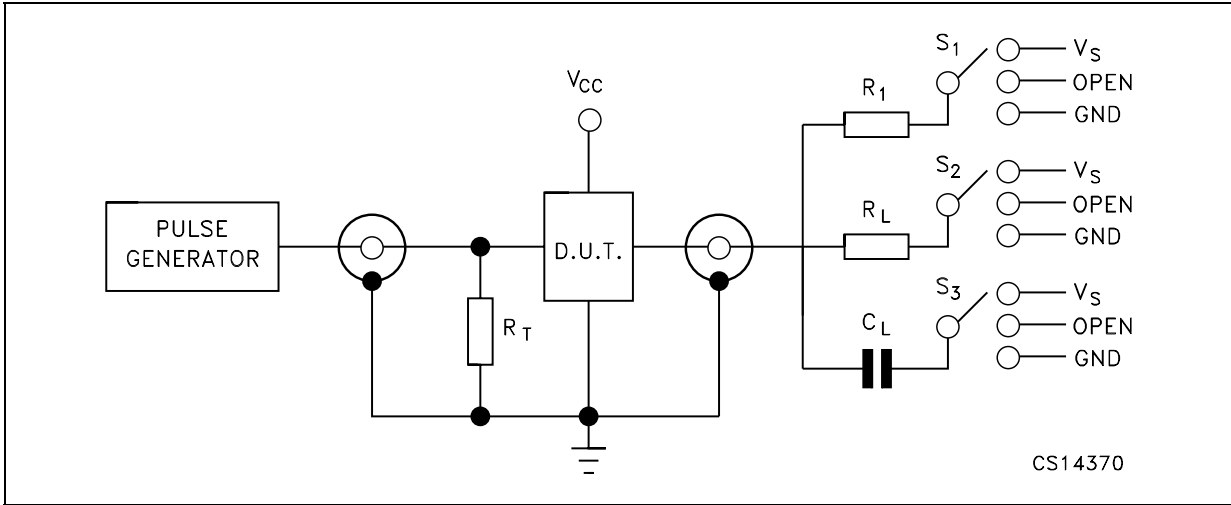

TEST	S1	S2	S3
$t_{PHL}$ (A1-A8 to B1-B8, A9-A13 to Y9-Y13, PLH <sub>IN</sub> to PLH) (see waveform 2)	Open	V <sub>CC</sub>	V <sub>CC</sub>
$t_{PLH}$ (A1-A8 to B1-B8, A9-A13 to Y9-Y13, PLH <sub>IN</sub> to PLH, HD to B1-B8, Y9-Y13, PLH) (see waveform 2)	Open	GND	GND
$t_{PHL}$ , $t_{PLH}$ (B1-B8 to A1-A8, C14-C17 to A14-A17, HLH <sub>IN</sub> to HLH) (see waveform 3)	Open	GND	GND
$t_r$ , $t_f$ (A1-A8 to B1-B8, A9-A13 to Y9-Y13) (see waveform 2)	Open	V <sub>CC</sub>	GND
$t_{PLZ}$ (DIR to A1-A8) (see waveform 5)	6V	GND	GND
$t_{PHZ}$ (DIR to A1-A8) (see waveform 5)	Open	GND	GND
$t_{PZL}$ (DIR to A1-A8) (see waveform 4)	1.4V	GND	GND
$t_{PZH}$ (DIR to A1-A8) (see waveform 4)	4.4V	GND	GND
$t_{PLZ}$ (DIR to B1-B8) (see waveform 5)	6V	GND	GND
$t_{PHZ}$ (DIR to B1-B8) (see waveform 5)	Open	GND	GND

$C_L$  = 50 pF or equivalent (includes jig and probe capacitance)  
 $R_L$  =  $R_1$  = 500Ω or equivalent  
 $R_T$  =  $Z_{OUT}$  of pulse generator (typically 50Ω)

WAVEFORM 1: ERROR-FREE CIRCUIT TIMING CHART (f=1MHz; 50% duty cycle)

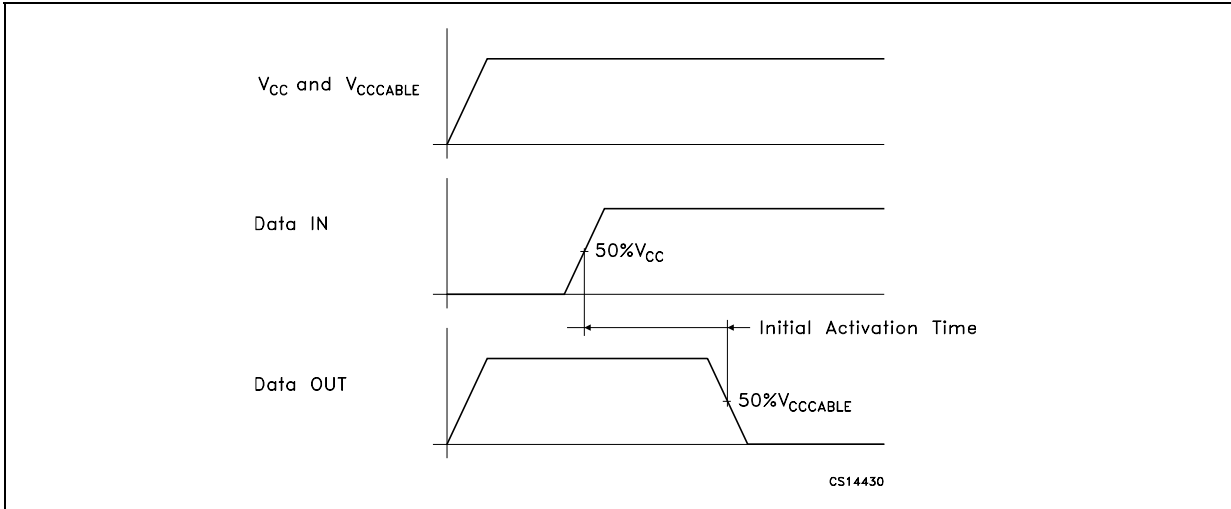

WAVEFORM 2: PROPAGATION DELAY INPUT An TO OUTPUT (f=1MHz; 50% duty cycle)

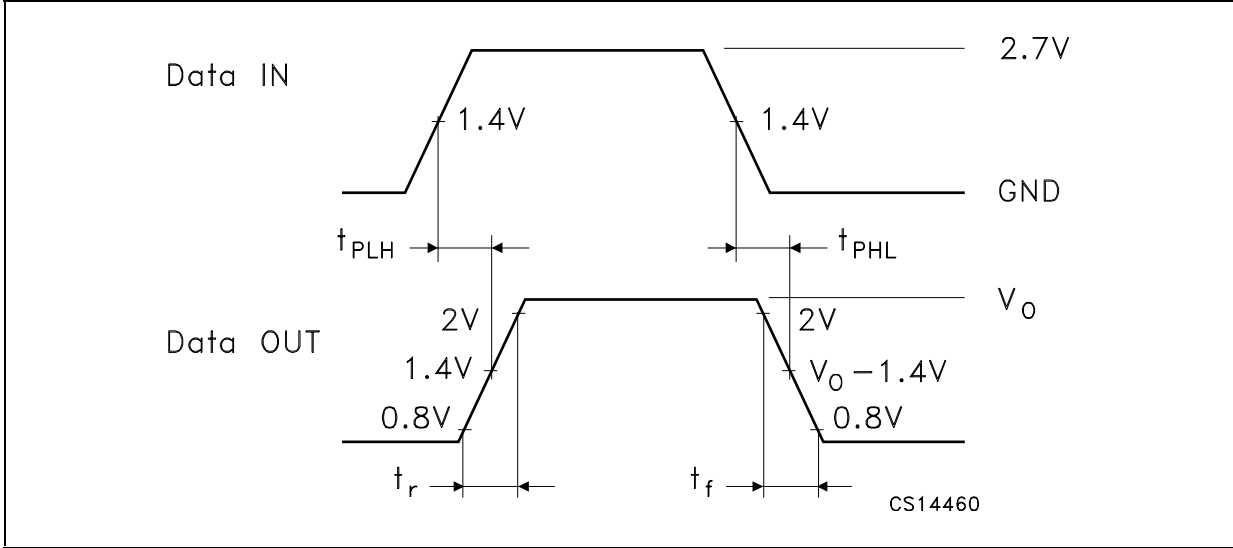

WAVEFORM 3: PROPAGATION DELAY INPUT Bn TO OUTPUT (f=1MHz; 50% duty cycle)

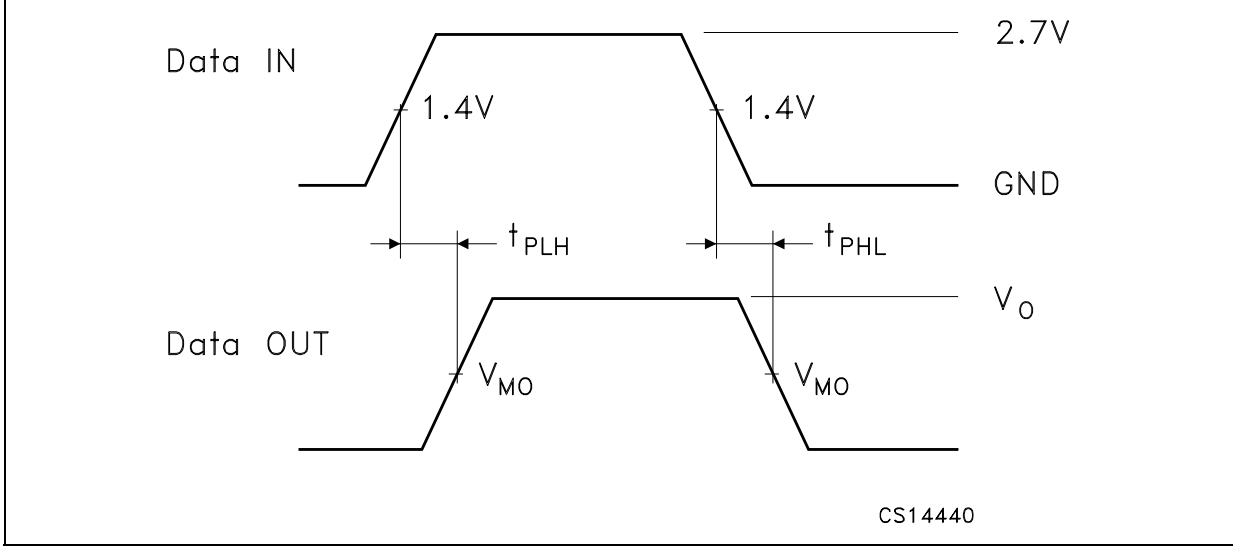

$V_{MO} = 50\%V_{CC}$



WAVEFORM 4: DATA TO OUTPUT ENABLE AND DISABLE TIME (f=1MHz; 50% duty cycle)

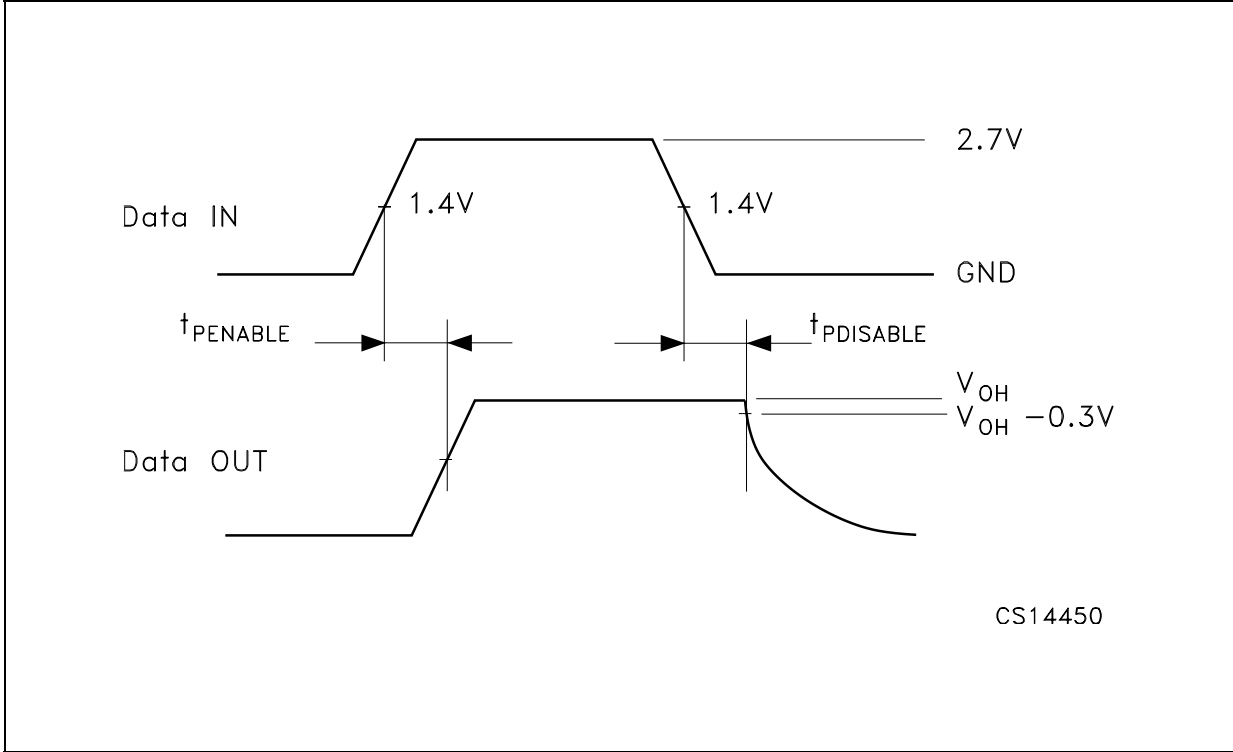

WAVEFORM 5: DIR TO OUTPUT ENABLE AND DISABLE TIME (f=1MHz; 50% duty cycle)

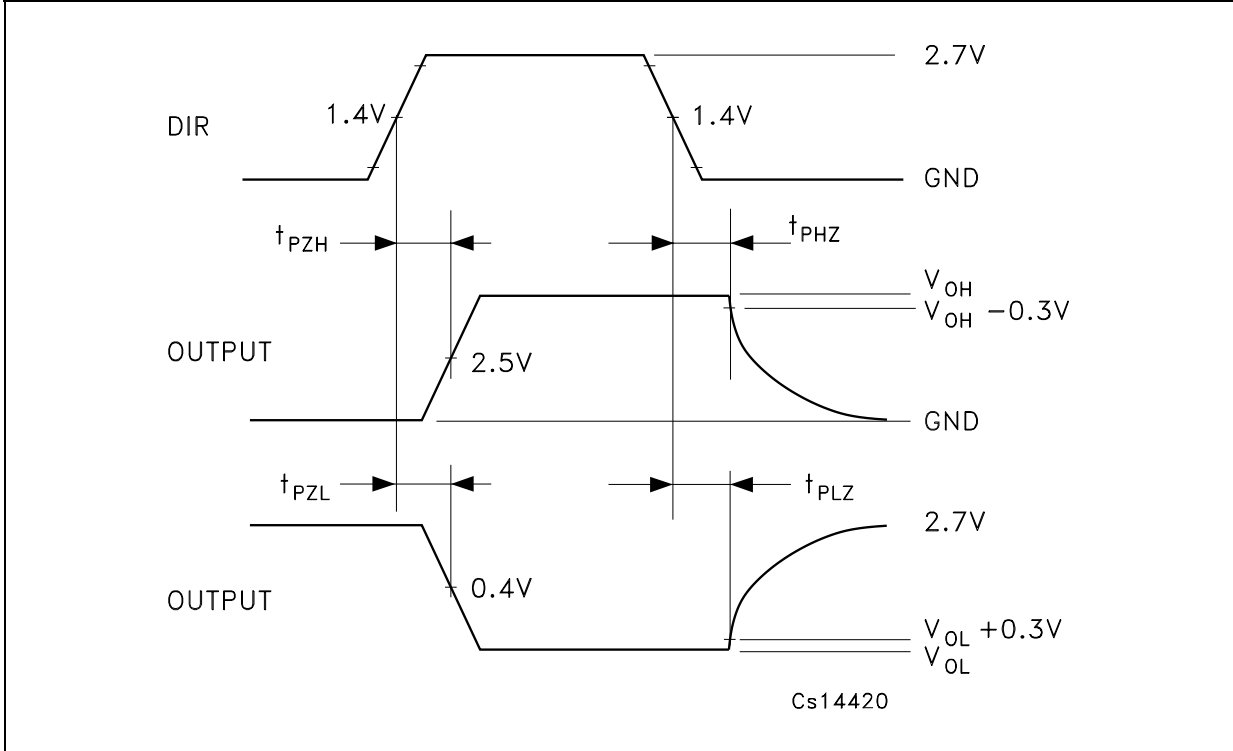

## TSSOP48 MECHANICAL DATA

DIM.	mm.			inch		
	MIN.	TYP.	MAX.	MIN.	TYP.	MAX.
A			1.2			0.047
A1	0.05		0.15	0.002		0.006
A2		0.9			0.035	
b	0.17		0.27	0.0067		0.011
c	0.09		0.20	0.0035		0.0079
D	12.4		12.6	0.488		0.496
E		8.1 BSC			0.318 BSC	
E1	6.0		6.2	0.236		0.244
e		0.5 BSC			0.0197 BSC	
K	0°		8°	0°		8°
L	0.45		0.75	0.018		0.030

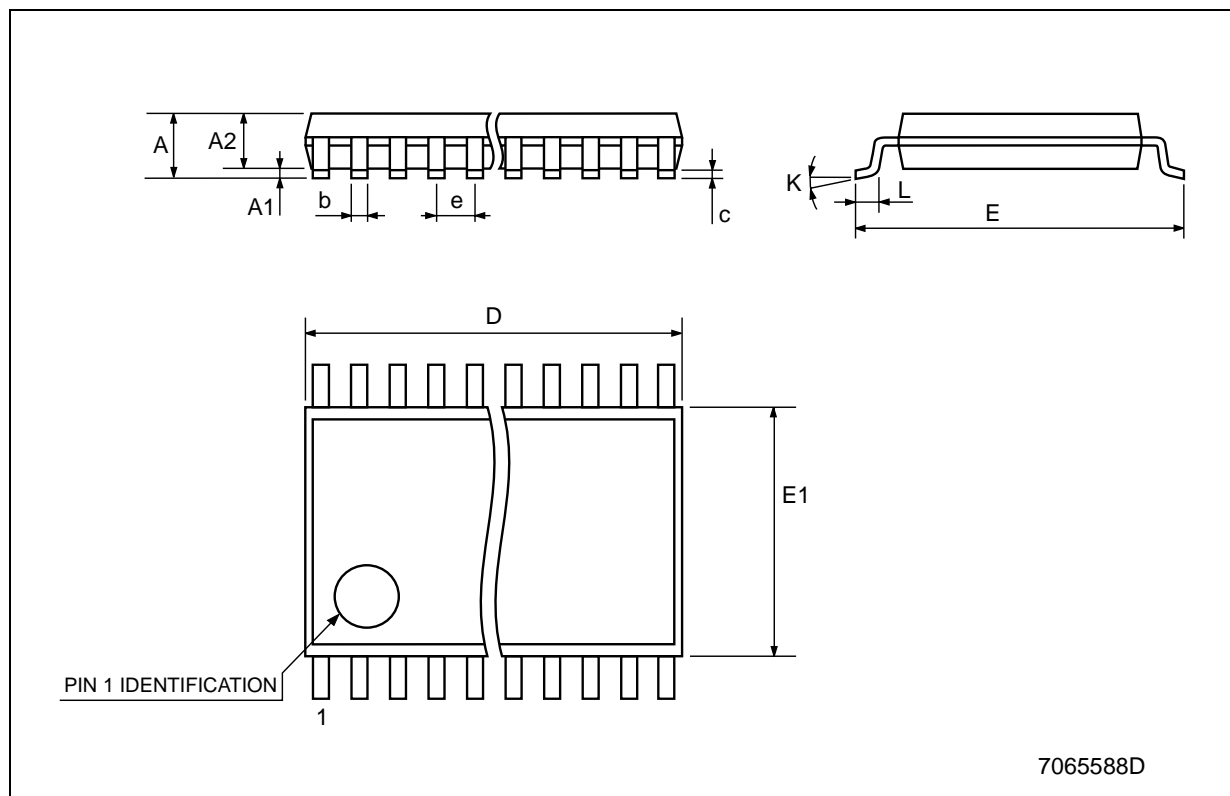

**Tape & Reel TSSOP48 MECHANICAL DATA**

DIM.	mm.			inch		
	MIN.	TYP	MAX.	MIN.	TYP.	MAX.
A			330			12.992
C	12.8		13.2	0.504		0.519
D	20.2			0.795		
N	60			2.362		
T			30.4			1.197
Ao	8.7		8.9	0.343		0.350
Bo	13.1		13.3	0.516		0.524
Ko	1.5		1.7	0.059		0.067
Po	3.9		4.1	0.153		0.161
P	11.9		12.1	0.468		0.476

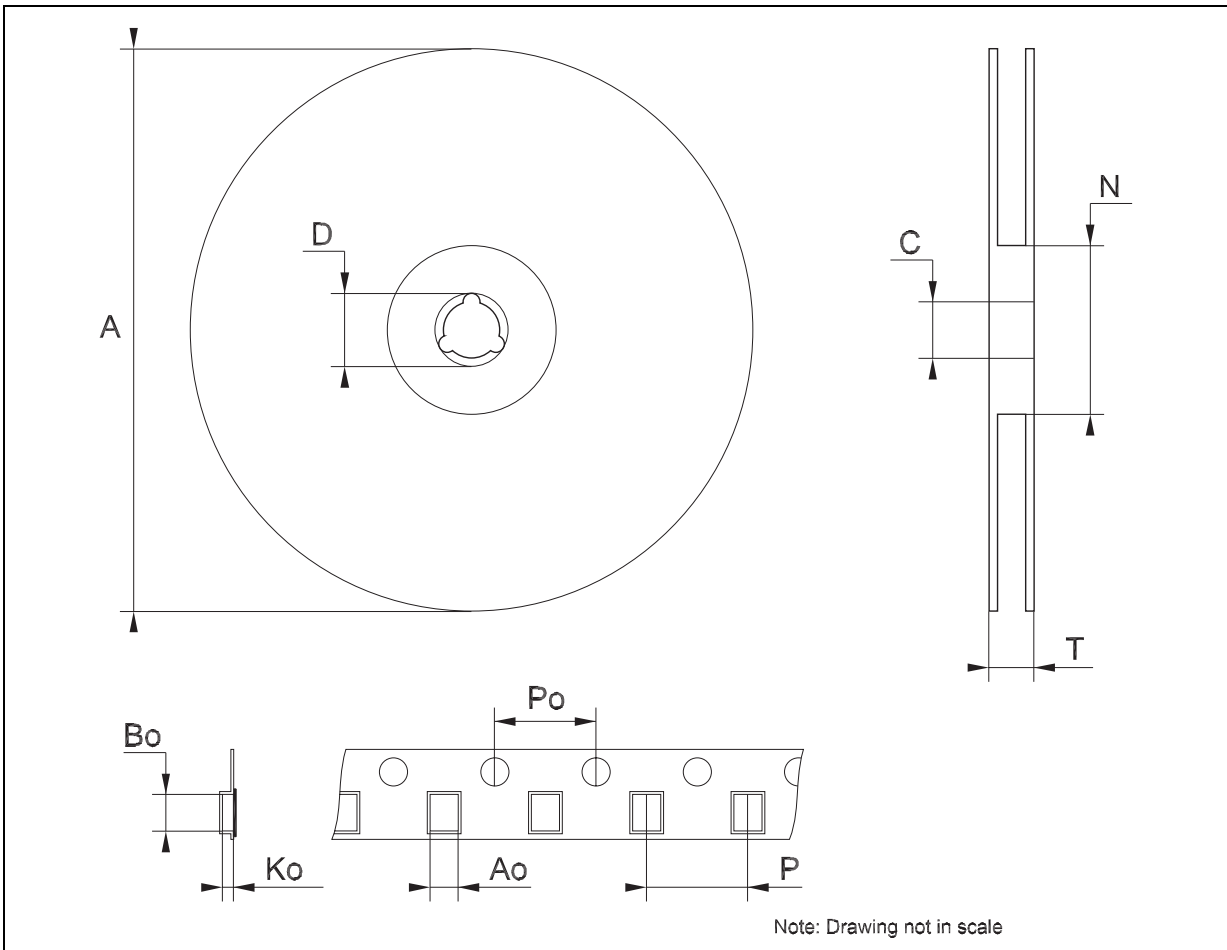

Information furnished is believed to be accurate and reliable. However, STMicroelectronics assumes no responsibility for the consequences of use of such information nor for any infringement of patents or other rights of third parties which may result from its use. No license is granted by implication or otherwise under any patent or patent rights of STMicroelectronics. Specifications mentioned in this publication are subject to change without notice. This publication supersedes and replaces all information previously supplied. STMicroelectronics products are not authorized for use as critical components in life support devices or systems without express written approval of STMicroelectronics.

The ST logo is a registered trademark of STMicroelectronics

All other names are the property of their respective owners

© 2005 STMicroelectronics - All Rights Reserved

STMicroelectronics group of companies

Australia - Belgium - Brazil - Canada - China - Czech Republic - Finland - France - Germany - Hong Kong - India - Israel - Italy - Japan - Malaysia - Malta - Morocco - Singapore - Spain - Sweden - Switzerland - United Kingdom - United States of America

[www.st.com](http://www.st.com)