

## Single PNP-Operational Amplifiers

TAE 1453  
TAF 1453

### Bipolar IC

#### Features

- PNP input
- Supply voltage range between 3 V and 36 V
- Low current consumption, 0.25 mA typ.
- Extremely large control range
- Low output saturation voltage, almost independent of load current
- Output current up to 70 mA (100 mA max.)
- Wide common-mode range
- Wide operating temperature range (TAF 1453)
- Open collector output

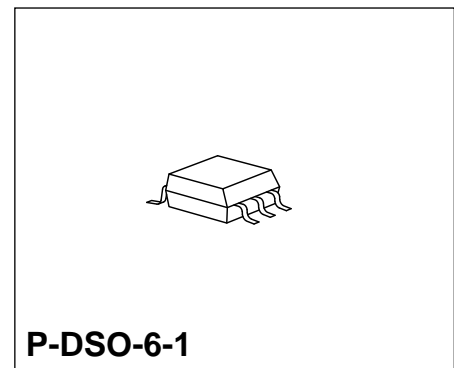

#### Applications

- Amplifier
- Level converter
- Driver
- Zero voltage switch
- Comparator

Type	Ordering Code	Package
TAE 1453 G	Q67000-A2106	P-DSO-6-1 (SMD)
TAF 1453 G	Q67000-A2209	P-DSO-6-1 (SMD)

These operational amplifiers are circuits for universal applications having a PNP-input differential stage and an open collector output. Apart from one resistor, only active components are used. The integrated regulator provides for all parameters a large degree of independence from the supply voltage.

## Pin Configurations (top view)

TAE 1453 G  
TAF 1453 G

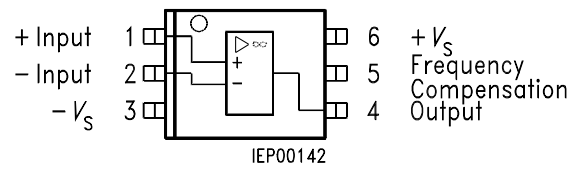

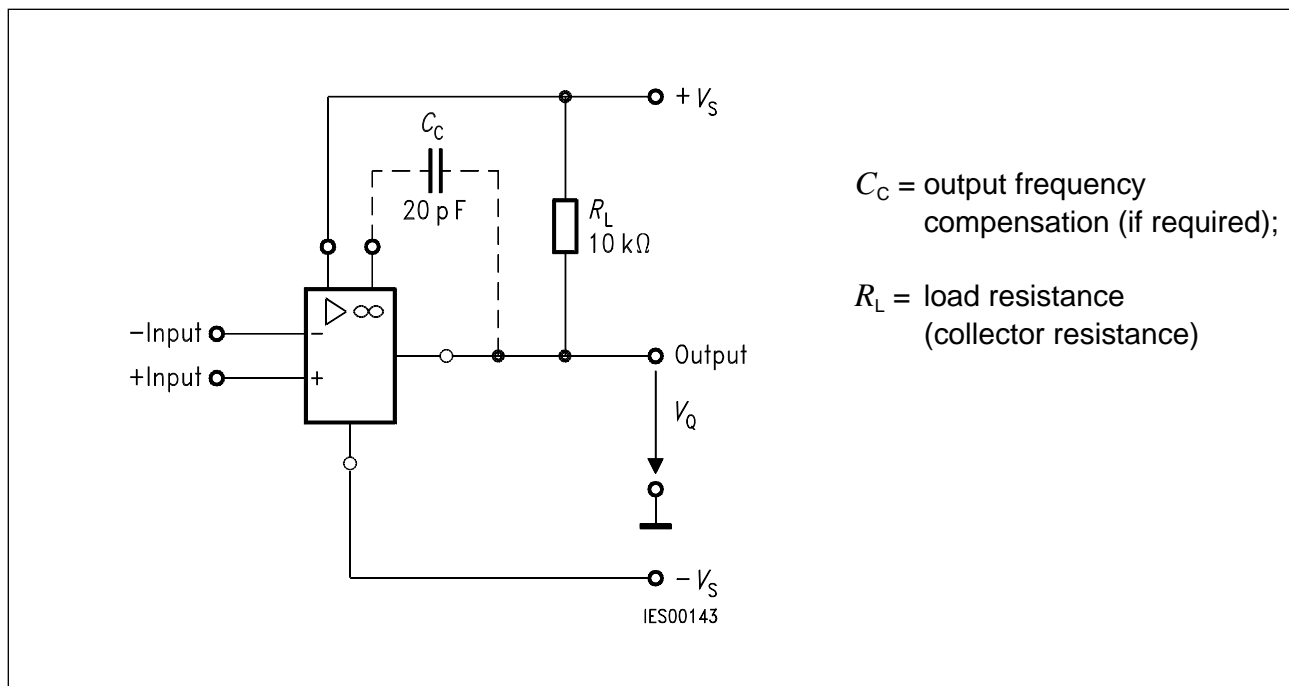

**Connection Diagram**

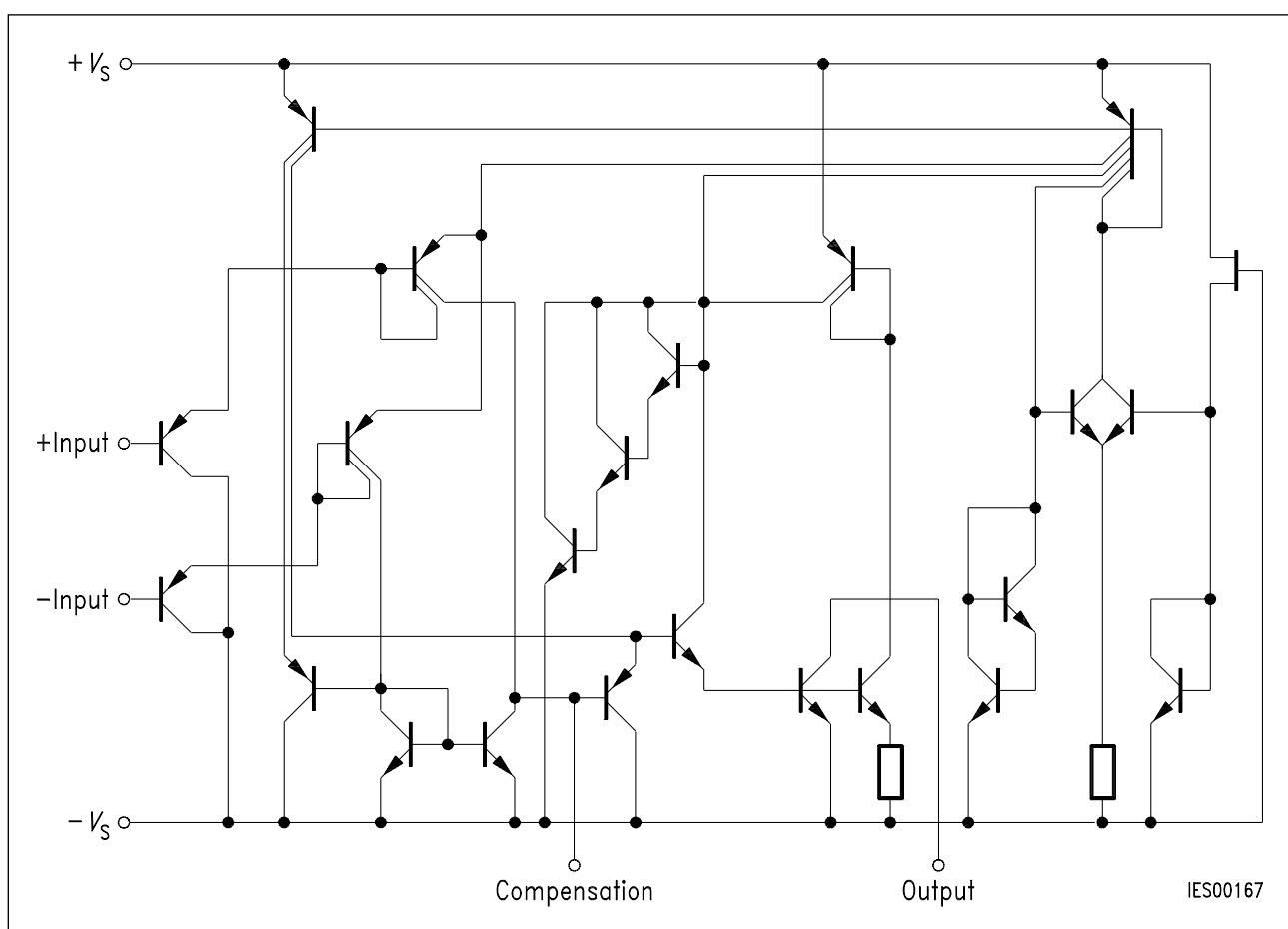

**Circuit Diagram**

## Absolute Maximum Ratings (TAE 1453 G)

Parameter	Symbol	Limit Values	Unit
Supply voltage	$V_S$	$\pm 18$	V
Output current	$I_Q$	100	mA
Differential input voltage	$V_{ID}$	$\pm V_S$	V
Junction temperature	$T_j$	150	$^{\circ}\text{C}$
Storage temperature range	$T_{stg}$	- 55 to 150	$^{\circ}\text{C}$
Thermal resistance system - air TAE 1453 G	$R_{th SA}$	200	K/W

## Operating Range (TAE 1453 G)

Supply voltage	$V_S$	$\pm 2$ to $\pm 18$ ( $\pm 1.5$ V with slightly increased offset voltage)	V
Ambient temperature	$T_A$	- 25 to 85	$^{\circ}\text{C}$

## Characteristics (TAE 1453 G)

$V_S = \pm 5$  V to  $\pm 15$  V;  $R_L = 10$  k $\Omega$ , unless otherwise specified

Parameter	Symbol	Limit Values $T_A = 25$ $^{\circ}\text{C}$			Limit Values $T_A = - 25$ to $85$ $^{\circ}\text{C}$		Unit
		min.	typ.	max.	min.	max.	
Open-loop current consumption	$I_S$		0.25	0.4		0.45	mA
Input offset voltage, $R_G = 50$ $\Omega$	$V_{IO}$	- 5.5		5.5	- 7	7	mV
Input offset current	$I_{IO}$	- 15		15	- 100	100	nA
Input current	$I_I$		40	150		200	nA

## Characteristics (TAE 1453 G) (cont'd)

$V_S = \pm 5\text{ V to } \pm 15\text{ V}$ ;  $R_L = 10\text{ k}\Omega$ , unless otherwise specified

Parameter	Symbol	Limit Values $T_A = 25\text{ }^\circ\text{C}$			Limit Values $T_A = -25$ to $85\text{ }^\circ\text{C}$		Unit
		min.	typ.	max.	min.	max.	
Control range $R_L = 2\text{ k}\Omega$ , $V_S = \pm 15\text{ V}$	$V_{Q\text{ pp}}$	14.9		-14.7	14.9	-14.7	V
$R_L = 620\text{ }\Omega$ , $V_S = \pm 15\text{ V}$	$V_{Q\text{ pp}}$	14.9		-14.5	14.9	-14.4	V
$R_L = 2\text{ k}\Omega$ , $V_S = \pm 15\text{ V}$ , $f = 100\text{ kHz}$	$V_{Q\text{ pp}}$	10		-10			V
Input impedance, $f = 1\text{ kHz}$	$Z_I$		200				k $\Omega$
Open-loop voltage gain	$G_{V0}$	78	85		78		dB
Output reverse current	$I_{QR}$			10		20	$\mu\text{A}$
Common-mode input voltage range	$V_{IC}$	$-V_S$ -0.2		$V_S$ -1.8	$-V_S$	$V_S$ -2.0	V
Common-mode rejection	$k_{CMR}$	75	80		75		dB
Supply voltage rejection $G_V = 100$	$k_{SVR}$		25	100		120	$\mu\text{V/V}$
Temperature coefficient of $I_{IO}$ $R_G = 50\text{ }\Omega$	$\alpha_{IIO}$		0.1				nA/K
Temperature coefficient of $V_{IO}$ $R_G = 50\text{ }\Omega$	$\alpha_{VIO}$		6				$\mu\text{V/K}$
Slew rate for non-inverting operation	$SR$		6		3	11	V/ $\mu\text{s}^1$ )
Slew rate for inverting operation	$SR$		6		3	10	V/ $\mu\text{s}^1$ )

1)  $C_k = 15\text{ pF}$

## Characteristics (TAE 1453 G)

$$V_S = \pm 2.5 \text{ V}, R_L = 10 \text{ k}\Omega$$

Parameter	Symbol	Limit Values $T_A = 25 \text{ }^\circ\text{C}$			Limit Values $T_A = -25$ to $85 \text{ }^\circ\text{C}$		Unit
		min.	typ.	max.	min.	max.	
Input offset voltage, $R_G = 50 \text{ }\Omega$	$V_{IO}$	-6		6	-7.5	7.5	mV
Input offset current	$I_{IO}$	-15		15	-100	100	nA
Input current	$I_I$		40	150		200	nA
Open-loop voltage gain	$G_{V0}$	70			70		dB

## Absolute Maximum Ratings (TAF 1453 G)

Parameter	Symbol	Limit Values	Unit
Supply voltage	$V_S$	$\pm 18$	V
Output current	$I_Q$	100	mA
Differential input voltage	$V_{ID}$	$\pm V_S$	V
Junction temperature	$T_j$	150	$^\circ\text{C}$
Storage temperature range	$T_{stg}$	-55 to 125	$^\circ\text{C}$
Thermal resistance system - air TAF 1453 G	$R_{th SA}$	200	K/W

## Operating Range (TAF 1453 G)

Supply voltage	$V_S$	$\pm 2$ to $\pm 18$ ( $\pm 1.5 \text{ V}$ with slightly increased offset voltage)	V
Ambient temperature	$T_A$	-55 to 125	$^\circ\text{C}$

## Characteristics (TAF 1453 G)

$V_S = \pm 5 \text{ V to } \pm 15 \text{ V}$ ;  $R_L = 10 \text{ k}\Omega$ , unless otherwise specified

Parameter	Symbol	Limit Values $T_A = 25 \text{ }^\circ\text{C}$			Limit Values $T_A = -55$ to $125 \text{ }^\circ\text{C}$		Unit
		min.	typ.	max.	min.	max.	
Open-loop current consumption (Output in H state)	$I_S$		0.25	0.35		0.45	mA
Input offset voltage, $R_G = 50 \text{ }\Omega$	$V_{IO}$	-4		4	-6	6	mV
Input offset current	$I_{IO}$	-10		10	-75	75	nA
Input current	$I_I$		40	100		150	nA
Control range							
$R_L = 2 \text{ k}\Omega$ , $V_S = \pm 15 \text{ V}$	$V_{Q\text{pp}}$	14.9		-14.7	14.9	-14.7	V
$R_L = 620 \text{ }\Omega$ , $V_S = \pm 15 \text{ V}$	$V_{Q\text{pp}}$	14.9		-14.5	14.9	-14.4	V
$R_L = 2 \text{ k}\Omega$ , $V_S = \pm 15 \text{ V}$ , $f = 100 \text{ kHz}$	$V_{Q\text{pp}}$	10		-10			V
Input impedance, $f = 1 \text{ kHz}$	$Z_I$		200				k $\Omega$
Open-loop voltage gain	$G_{V0}$	80	85		75		dB
Output reverse current	$I_{QR}$			1		5	$\mu\text{A}$
Common-mode input voltage range	$V_{IC}$	$-V_S$ -0.2		$V_S$ -1.5	$-V_S$ +0.2	$V_S$ -1.8	V
Common-mode rejection	$k_{CMR}$	80	85		75		dB
Supply voltage rejection $G_V = 100$	$k_{SVR}$		25	100		100	$\mu\text{V/V}$
Temperature coefficient of $I_{IO}$ $R_G = 50 \text{ }\Omega$	$\alpha_{IIO}$		0.1	0.8			nA/K
Temperature coefficient of $V_{IO}$ $R_G = 50 \text{ }\Omega$	$\alpha_{VIO}$		6	25			$\mu\text{V/K}$

## Characteristics (TAF 1453 G)

$V_S = \pm 2.5 \text{ V}$ ,  $R_L = 10 \text{ k}\Omega$

Parameter	Symbol	Limit Values $T_A = 25 \text{ }^\circ\text{C}$			Limit Values $T_A = -55$ to $125 \text{ }^\circ\text{C}$		Unit
		min.	typ.	max.	min.	max.	
Slew rate for non-inverting operation	$SR$		6		2	12	$\text{V}/\mu\text{s}^{1)}$
Slew rate for inverting operation	$SR$		6		2	11	$\text{V}/\mu\text{s}^{1)}$
Input offset voltage, $R_G = 50 \text{ }\Omega$	$V_{IO}$	-4		4	-6	6	mV
Input offset current	$I_{IO}$	-50		50	-75	75	nA
Input current	$I_I$		40	100		150	nA
Open-loop voltage gain	$G_{V0}$	75			70		dB

<sup>1)</sup>  $C_k = 15 \text{ pF}$



## Typical Characteristics of Electrical Parameters

### Load Characteristics Output Saturation Voltage versus Output Current

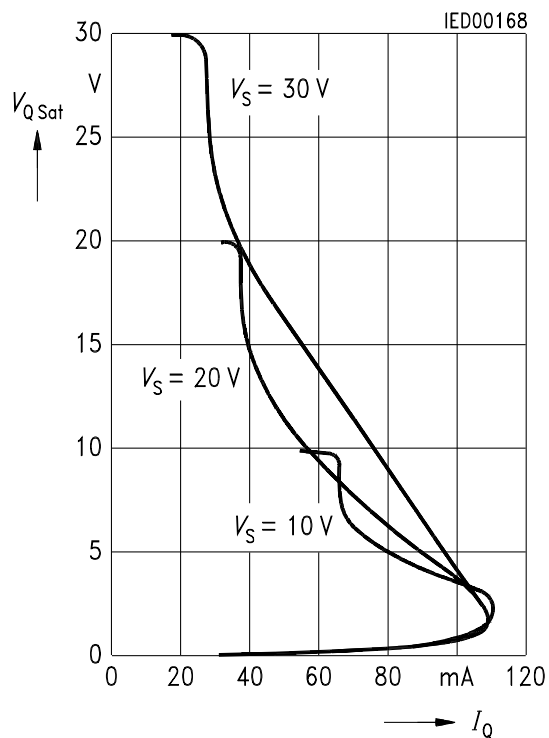

### Output Saturation Voltage versus Output Current

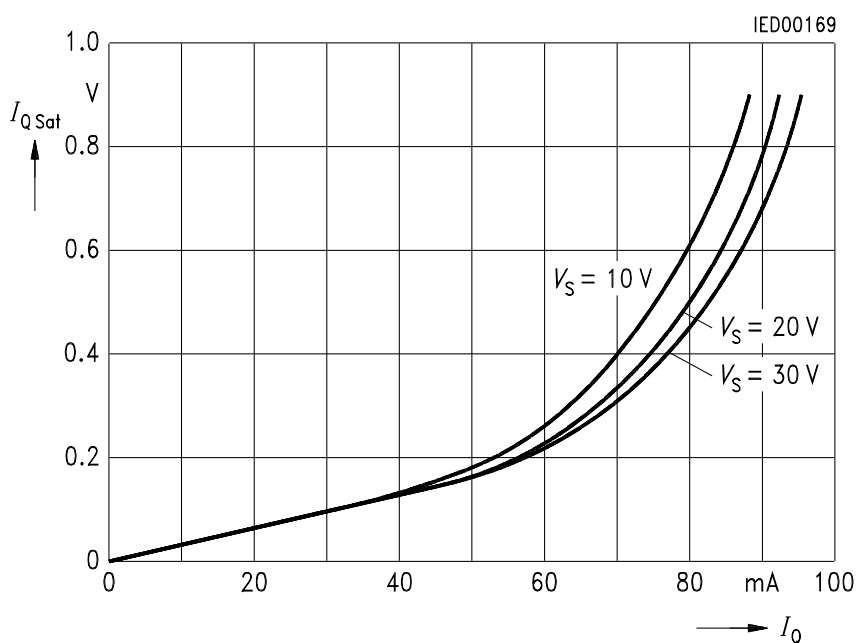

## Supply Current versus Supply Voltage

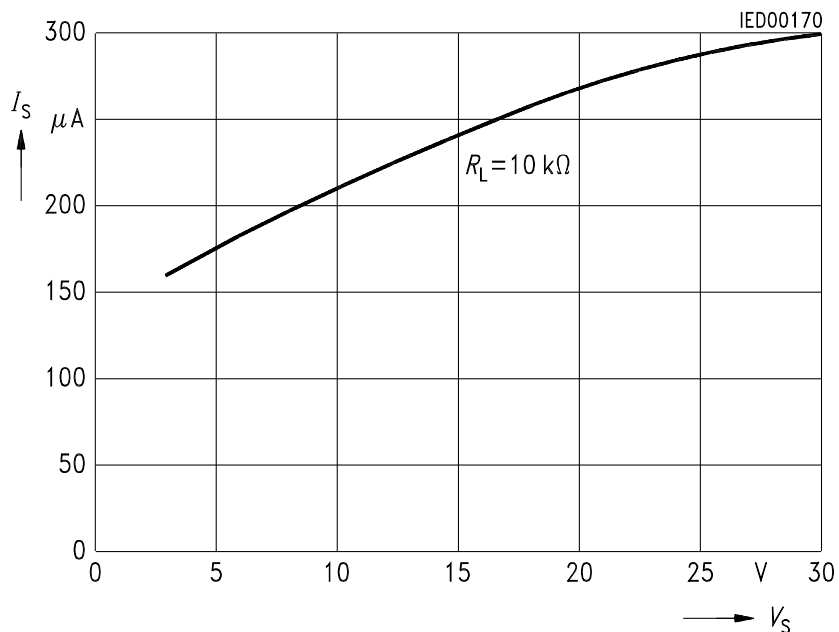

## Input Current and Input Offset Current versus Supply Voltage

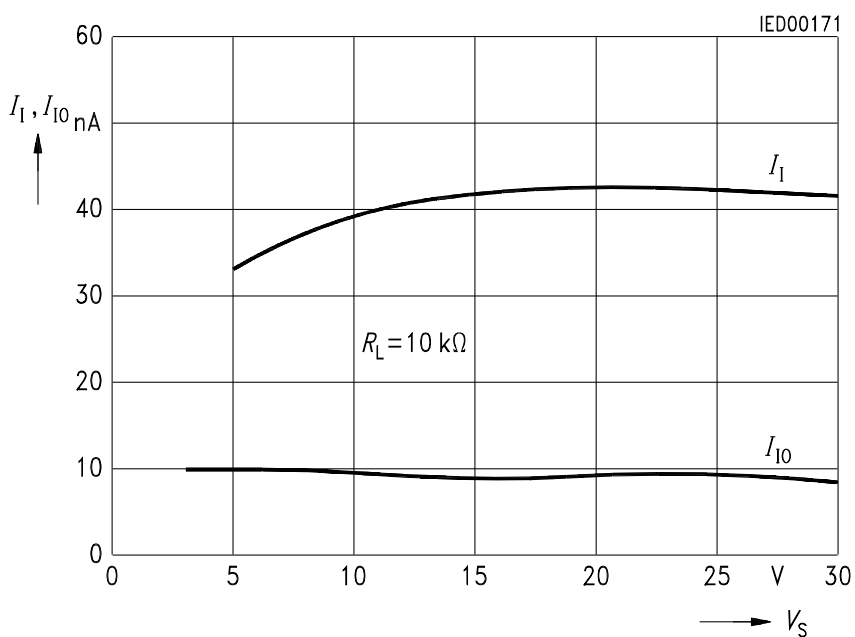

## Input Offset Voltage versus Supply Voltage

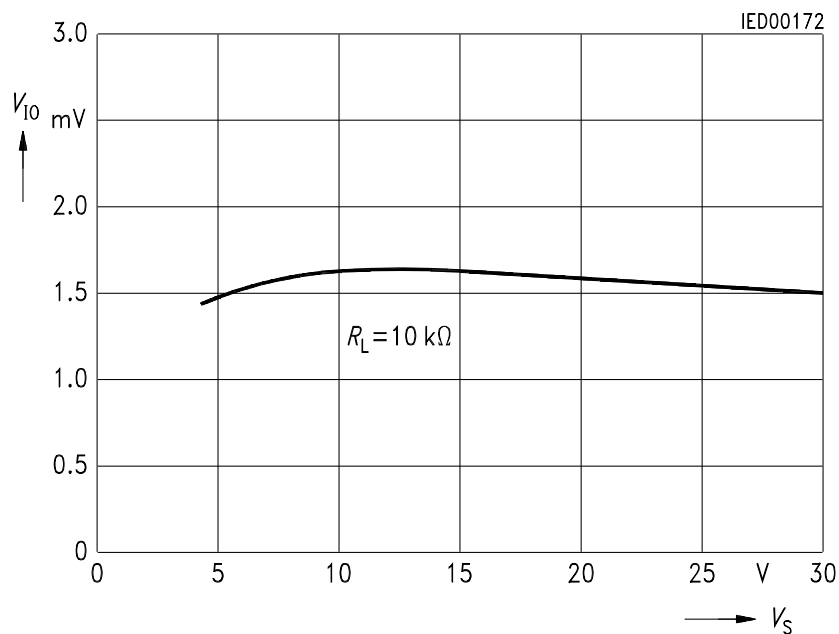

## $V_{10}$ Behavior at Low Operating Voltages Input Offset Voltage versus Supply Voltage

