

**PS/2 MOUSE CONTROLLER****DESCRIPTION**

The SC84502 Mouse Controller is specially designed to control PS/2 mouse device. This single chip can interface three key-switches and four photo-couples direct to 8042. SC84502 can receive command and echo status or data format which are compatible with IBM PS/2 mode mouse. Key debouncing circuit is provided to prevent false entry and improve the accuracy.

In the conventional mouse, a great number of noises are generated when the grid is partially closed or opened. These noise are usually mistaken for movement signals by conventional mouse controller and the cursor of the display screen is thus moved frequently up and down or back and forth. This will consumes a great amount of energy. The SC84502 PS/2 mouse controller provides noise immunity circuits to eliminate these noise In order to reduce energy consumption.

**FEATURES**

- \* Being compatible with PS/2 mouse mode
- \* Built-in noise immunity circuit
- \* Low power dissipation
- \* RC oscillation
- \* Three key-switches and four photo-couples inputs
- \* Both key-press and key-release debounce interval 12ms
- \* Through three key-switches input, SC84502 can exert seven different output
- \* The motion detector of the SC84502 could sense 8m/sec maximum with 200 DPI wheels

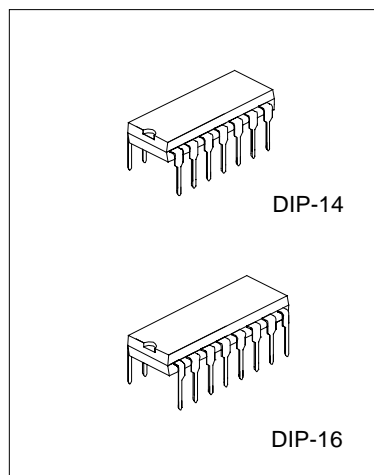
**ORDERING INFORMATION**

SC84502AP	DIP-14 PACKAGE
SC84502BP	DIP-16 PACKAGE

**APPLICATIONS**

- \* Optical mouse or pen-mouse
- \* Mechanical mouse or pen-mouse
- \* Optomechanical mouse or pen-mouse
- \* Mechanical track ball
- \* Optomechanical track ball

**PIN CONFIGURATIONS**

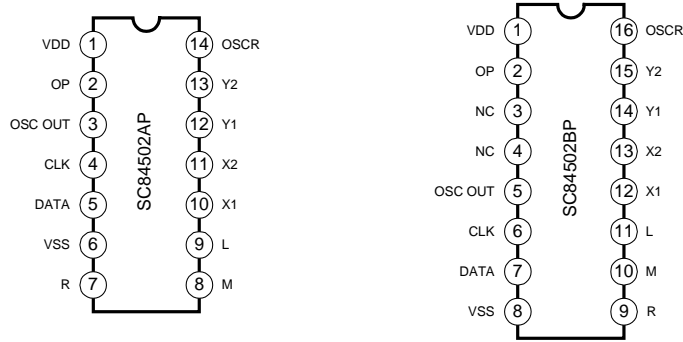

**BLOCK DIAGRAM** ( Refer to SC84502BP )

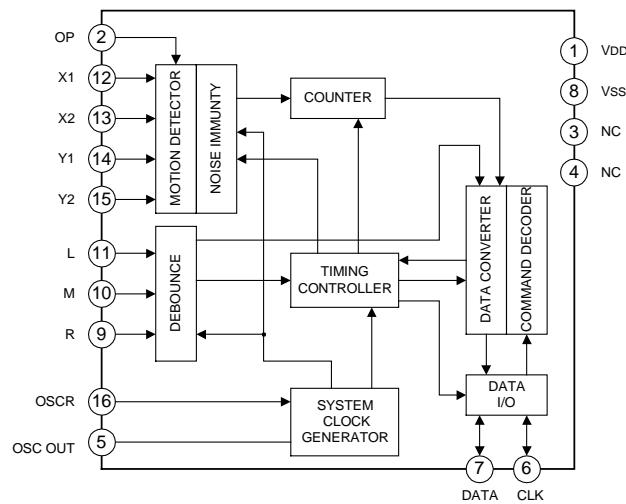

**DC ELECTRICAL CHARACTERISTICS** (Tamb=25~70°C)

Parameter	Symbol	Condition	Min	Typ	Max	Unit
Operating Voltage	VDD	--	4.5	5	5.5	V
Operating Current	Iop	No Load	--	--	1.2	mA
X1,X2,Y1,Y2 Low Input reference current	Ipl	--	70	--	--	μA
X1,X2,Y1,Y2 High Input reference current	Iph	--	--	--	106	μA

(to be continued)

————— **HANGZHOU SILAN MICROELECTRONICS JOINT-STOCK CO.,LTD** —————

Rev: 1.0 2000.12.31

(continued)

Parameter	Symbol	Condition	Min	Typ	Max	Unit
X1,X2,Y1,Y2 input current	V <sub>pl</sub>	Schmitt trigger input, I <sub>pl</sub> =76μA	0.8	--	1.2	V
		Comparator input, I <sub>pl</sub> =80μA	0.8	--	1.2	V
		Comparator input, I <sub>pl</sub> =500μA	1.5	--	2.1	V
CLK, DATA positive-going threshold voltage	V <sub>t+</sub>	--	3.2	--	3.8	V
CLK, DATA negative-going threshold voltage	V <sub>t-</sub>	--	1.2	--	1.9	V
Low Input Voltage, Other Pins	V <sub>ail</sub>	--	--	--	1.5	V
High Input Voltage, Other Pins	V <sub>aih</sub>	--	3.5	--	--	V
L,M,R Input Current	I <sub>mi</sub>	Pull Up Resistor, V <sub>in</sub> =5V	16.6	--	50	μA
PS/2 mouse mode DATA,CLK input Current	I <sub>dc</sub>	V <sub>in</sub> = 0V	0.56	--	1.86	mA
PS/2 mouse mode DATA,CLK low output Voltage	V <sub>prl</sub>	I <sub>prl</sub> = -2 mA	--	--	0.4	V
L,M,R,X1,X2,Y1,Y2 Input Leakage Current	I <sub>il</sub>	V <sub>in</sub> = 0V	0	--	1.0	μA

Note: All voltages in above table are compared with VSS.

All parameters in above table are tested under VDD=5V.

CLK & DATA output gates are open drains that connect to pull up resistors.

**AC ELECTRICAL CHARACTERISTICS** (T<sub>amb</sub> = 0 ~ 70°C)

Parameter	Symbol	Min	Typ	Max	Unit
Oscillating Frequency	F <sub>osc</sub>	34.3-10%	34.3	34.3+10%	kHz
Key Debounce	T <sub>kd</sub>	--	12	--	ms
Rising Edge Crossed Width F <sub>osc</sub> =35 kHz	T <sub>r</sub>	14.3	--	--	μs
Falling Edge Crossed Width F <sub>osc</sub> =35 kHz	T <sub>f</sub>	14.3	--	--	μs
Mouse CLK Active Time	T <sub>mca</sub>	--	42.9	--	μs
Mouse CLK Inactive Time	T <sub>mci</sub>	--	42.9	--	μs
Time that Mouse Sample DATA from CLK rising Edge	T <sub>m<sub>dc</sub></sub>	--	14.3	--	μs
System CLK Active Time	T <sub>sca</sub>	--	42.9	--	μs
System CLK Inactive Time	T <sub>s<sub>ci</sub></sub>	--	42.9	--	μs
Time from DATA Transition to Falling Edge of CLK	T <sub>s<sub>dc</sub></sub>	--	14.3	--	μs
Time from rising Edge of CLK to DATA Transition	T <sub>s<sub>cd</sub></sub>	--	28.6	--	μs
Time to mouse Inhibit after the 11th CLK to ensure mouse does not start another Transmission	T <sub>pi</sub>	0	--	50	μs

Note: The AC timings are measured under using 35kHz system clock signal.

————— **HANGZHOU SILAN MICROELECTRONICS JOINT-STOCK CO.,LTD** —————

Rev: 1.0 2000.12.31

**X1, X2, Y1, Y2 INPUT IMPEDANCE**

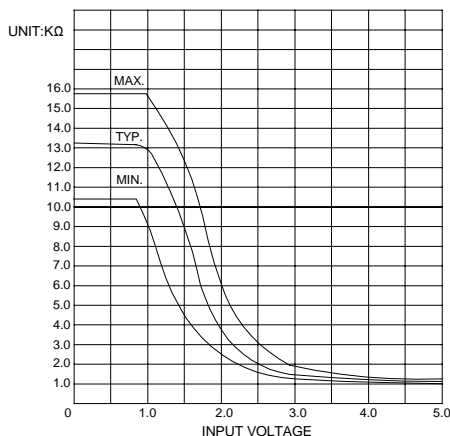

**PIN DESCRIPTION** (refer to SC84502BP)

Pin No.	Pin Name	I/O	Description
1	VDD	--	Positive Power Supply.
2	OP	I	X, Y inputs: Floating: Comparator input. GND: Schmitt trigger input. Short to OSC OUT: Testing Mode.
3	NC	--	No Connection
4	NC	--	No Connection
5	OSCOUT	O	Clock output.
6	CLK	I/O	8042 auxiliary port CLK line.
7	DATA	I/O	8042 auxiliary port DATA line.
8	VSS	--	Negative Power Supply
9	R	I	Three key-switches esert seven different combinations totally. Both key-pressed and key-released signals will be sent accompanied with horizontal and vertical state. The status of the key-switches will be preserved, whenever the value of horizontal or vertical counters will present at DATA. And the debounce interval for both key-press and key release is 12ms.
10	M		
11	L		
12	X1	I	Four photo-couple signal denote UP, DOWN, LEFT and RIGHT state. During the scanning period, as long as the photo-couples change their states, the value of vertical or horizontal, counter will increase or decrease accordingly.
13	X2		
14	Y1		
15	Y2		
16	OSCR	I	50kΩ ± 5% pull low for 35kHz oscillation

## FUNCTION DESCRIPTIONS

### 1. OPERATING MODE

There are four operating modes in PS/2 mouse:

i) Reset Mode:

In this mode a self-test is initiated during power-on or by a Reset command. After reset signal, PS/2 mouse will send:

1) Completion code AA&ID code 00.

2) Set default:

sampling rate: 100 reports/s

non-autospeed

stream mode

2 dot/count

disable

ii) Stream Mode:

The maximum rate of transfer is the programmed sample rate.

Data report is transmitted if

1) switch is pressed

2) movement has been detect

iii) Remote Mode:

Data is transmitted only in response to a Read Data command.

iv) Wrap Mode:

Any byte of data sent by the system, except hex EC(Reset wrap mode) or hex FF(Reset), is returned by SC84502.

### 2. PS/2 MOUSE DATA REPORT

i) In stream mode: A data report is sent at the end of a sample interval.

ii) In remote mode: A data report is sent in response to Read Data command.

iii) Data report format:

Byte	Bit	Description
1	0	Left button status; 1 = pressed
	1	Right button status; 1 = pressed
	2	Middle button status; 1 = pressed
	3	Reserve
	4	X data sign; 1 = negative
	5	Y data sign; 1 = negative
	6	X data overflow; 1 = overflow
2	7	Y data overflow; 1 = overflow
	0-7	X data(D0 ~ D7)
3	0-7	Y data(D0 ~ D7)

### 3.PS/2 MOUSE DATA TRANSMISSION

- i) SC84502 generates the clocking signal when sending data to and receiving data from the system.
- ii) The system requests SC84502 receive system data output by forcing the DATA line to an inactive level and allowing CLK line to go to an active level.
- iii) Data transmission frame:

Bit	Function
1	Start bit(always 0)
2 ~ 9	Data bits(D0 ~D7)
10	Parity bit(odd parity)
11	Stop bit (always 1)

- iv) Data Output (data from SC84502 to system)

If CLK is low (inhibit status), data is no transmission.

If CLK is high and DATA is low(request-to-send), data is updated. Data is received from the system and no transmission are started by SC84502 until CLK and DATA both high. If CLK and DATA are both high, the transmission is ready. DATA is valid prior to the falling edge of CLK and beyond the rising edge of CLK. During transmission, SC84502 check for line contention by checking for an inactive level on CLK at intervals not to exceed 100 $\mu$  sec. Contention occurs when the system lowers CLK to inhibit SC84502 output after SC84502 has started a transmission. If this occurs before the rising edge of the contention does not occur by the tenth clock, the transmission is complete.

Following a transmission, the system inhibits SC84502 by holding CLK low until it can service the input or until the system receives a request to send a response from SC84502.

v) Data Input (from system to SC84502)

System first check if SC84502 is transmitting data. If SC84502 is transmitting, the system can override the output forcing CLK to an inactive level prior to the tenth clock. If SC84502 transmission is beyond the tenth clock, the system receives the data. If SC84502 is not transmitting or if the system choose to override the output, the system force CLK to an inactive level for a period of not less than 100m sec while preparing for output. When the system is ready to output start bit (0), it allows CLK go to active level. If request-to-send is detected, SC84502 clocks 11 bits. Following the tenth clock SC84502 checks for an active level on the DATA line, and if found, force DATA low , and clock once more. If occurs framing error, SC84502 continue to clock until DATA is high, then clocks the line control bit and request a Resend. When the system sends out a command or data transmission that requires a response, the system waits for SC84502 to response before sending its next output.

#### 4. PS/2 MOUSE ERROR HANDLING

- i) A Resend command ( FE ) following receipt of an invalid input or any input with incorrect parity.
- ii) If two invalid input are received in succession, an error code of hex FC send to the system.
- iii) The counter accumulators are cleared after receiving any command except "Resend".
- iv) SC84501 receives a Resend command ( FE ), it transmit its last packet of data.
- v) In the stream mode "Resend" is received by SC84502 following a 3-byte data packet transmission to the system. SC84502 resend the 3-byte data packet prior to clearing the counter.
- vi) A response is sent within 25 ms if
  - a). The system requires a response
  - b). An error is detected in the transmission
- vii). When a command requiring a response is issued by the system ,another command should not be issue until either the response is received or 25ms has passed.

#### 5. PS/2 MOUSE COMMANDS DESCRIPTION

There are 16 valid commands that transmits between the system and SC84502. The "FA" code is always the first response to any valid input received from the system other than a Set Wrap Mode or Resend command.

The following table list the commands:

---

HANGZHOU SILAN MICROELECTRONICS JOINT-STOCK CO.,LTD

Rev: 1.0 2000.12.31

Hex Code	Command	SC84502 echo code
FF	Reset	FA, AA, 00
FE	Resend	XX, (XX, XX)
F6	Set Default	FA
F5	Disable	FA
F4	Enable	FA
F3, XX	Set Sampling Rate	FA, FA
F2	Read Device Type	FA, 00
F0	Set Remote Mode	FA
EE	Set Wrap Mode	FA
EC	Reset Wrap Mode	FA
EB	Read Data	FA, XX, XX, XX
EA	Set Stream Mode	FA
E9	Status Request	FA, XX, XX, XX
E8, XX	Set Resolution	EA, FA
E7	Set Autospeed	FA
E6	Reset Autospeed	FA

The following describes valid commands:

a). Reset ( FF )

SC84502 operation:

- i). Completion the reset.
- ii). Transmitted FA,AA,00 to the system.
- iii). Set default:
  - sampling rate: 100 reports/s
  - non-autospeed
  - stream mode
  - 2 dots/count
  - disable

b). Resend ( FE )

- i). Any time SC84502 receives an invalid command, it returns a Resend command to the system.
- ii). When SC84502 receives a Resend command, it retransmits its last packet of data. If the last packet was a Resend command, it transmits the packet just prior to the Resend command.
- iii). In stream mode, if a Resend command is received by SC84502 immediately following a 3-byte data packet transmission to the system.

————— **HANGZHOU SILAN MICROELECTRONICS JOINT-STOCK CO.,LTD** —————

Rev: 1.0 2000.12.31



## c). Set Default (F6)

The command reinitializes all conditions to the power-on defaults.

## d). Disable (F5)

This command is used in the stream mode to stop transmissions from SC84502.

## e). Enable (F4)

Begins transmissions, if in stream mode.

## f). Set Sampling Rate (F3, XX)

In the stream mode, this command sets the sampling rate to the value indicated by byte hex XX, shown in following:

Second byte XX	Sample Rate
0A	10/sec
14	20/sec
28	40/sec
3C	60/sec
50	80/sec
64	100/sec
C8	200/sec

## g). Read Device Type (F2)

SC84502 always echoes "FA, 00 " following this command.

## h). Set Remote Mode (F0)

Data values are reported only in response to a Read Data command.

## i). Set Wrap Mode (EE)

Wrap mode remains until Reset (FF) or Reset Wrap Mode (EC) is received.

## j). Reset Wrap Mode (EC)

SC84502 returns to the previous mode of operation after receiving this command.

## k). Read Data (EB)

This command is executed in either remote or stream mode. The data is transmitted even if there has been no movement since the last report or the button status is unchanged. Following a Read Data command, the registers are cleared after a data transmission.

## l). Set Stream Mode (EA)

This command sets SC84502 in stream mode.

## m). Status Request (E9)

When this command is issued by the system, SC84502 respond with a 3-byte status report as follows:

Byte	Bit	Description
1	0	1=Right button pressed
	1	1=Middle button pressed
	2	1= Left button pressed
	3	Reserved
	4	0=Normal speed, 1=Autospeed
	5	0=Disabled, 1=Enabled
	6	0=Stream mode, 1=Remote mode
	7	Reserved
2	0-7	Current resolution setting (D0-D7)
3	0-7	Current sampling rate (D0-D7)

## n). Set Resolution ( E8,XX )

SC84502 provides four resolutions selected by the second byte of this command as follows:

Second Byte XX	Resolution
00	8 dot/count
01	4 dot/count
02	2 dot/count
03	1 dot/count

## o). Set Autospeed ( E7 )

At the end of a sample interval in the stream mode, the current X and Y data values are converted new values. The sign bits are not involved in this conversion. The conversion is only in stream mode. The relationship between the input and output count follows:

Input	Output
0	0
1	1
2	1
3	3
4	6
5	9
N (≥6)	2.0*N

## p). Reset Autospeed ( E6 )

This command restore normal speed.

**6. TESTING MODE**

Whenever OPT is connected to OSC OUT, the chip will enter buyer's testing mode. The X direction output signals of comparators will present to L and M pin. Pressing "R" key can toggle the output from X direction to Y direction.

————— *HANGZHOU SILAN MICROELECTRONICS JOINT-STOCK CO.,LTD* —————

Rev: 1.0 2000.12.31

**TIMING DIAGRAM**

(1) Photo-couples pulse width

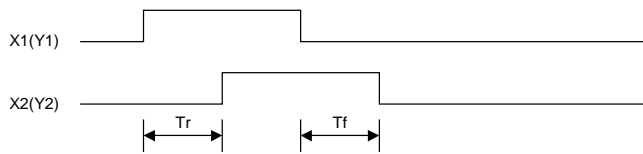

(2) PS/2 Mouse

(A) Receiving Data

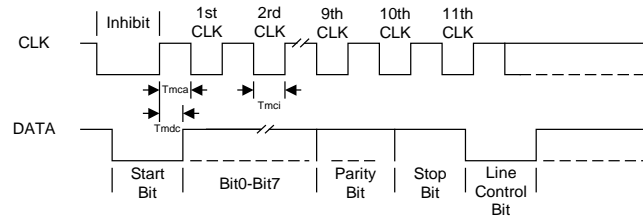

(B) Sending Data

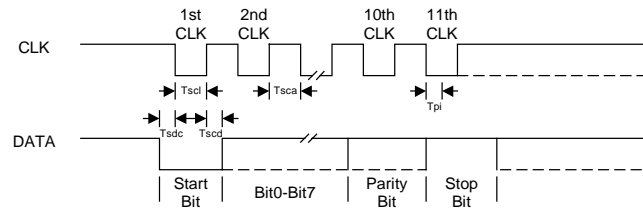

**AC TIMING POINT**

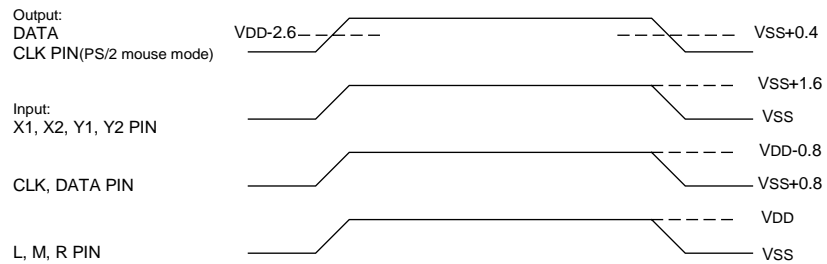

**SC84502 I/O PIN EQUIVALENT CIRCUITS**

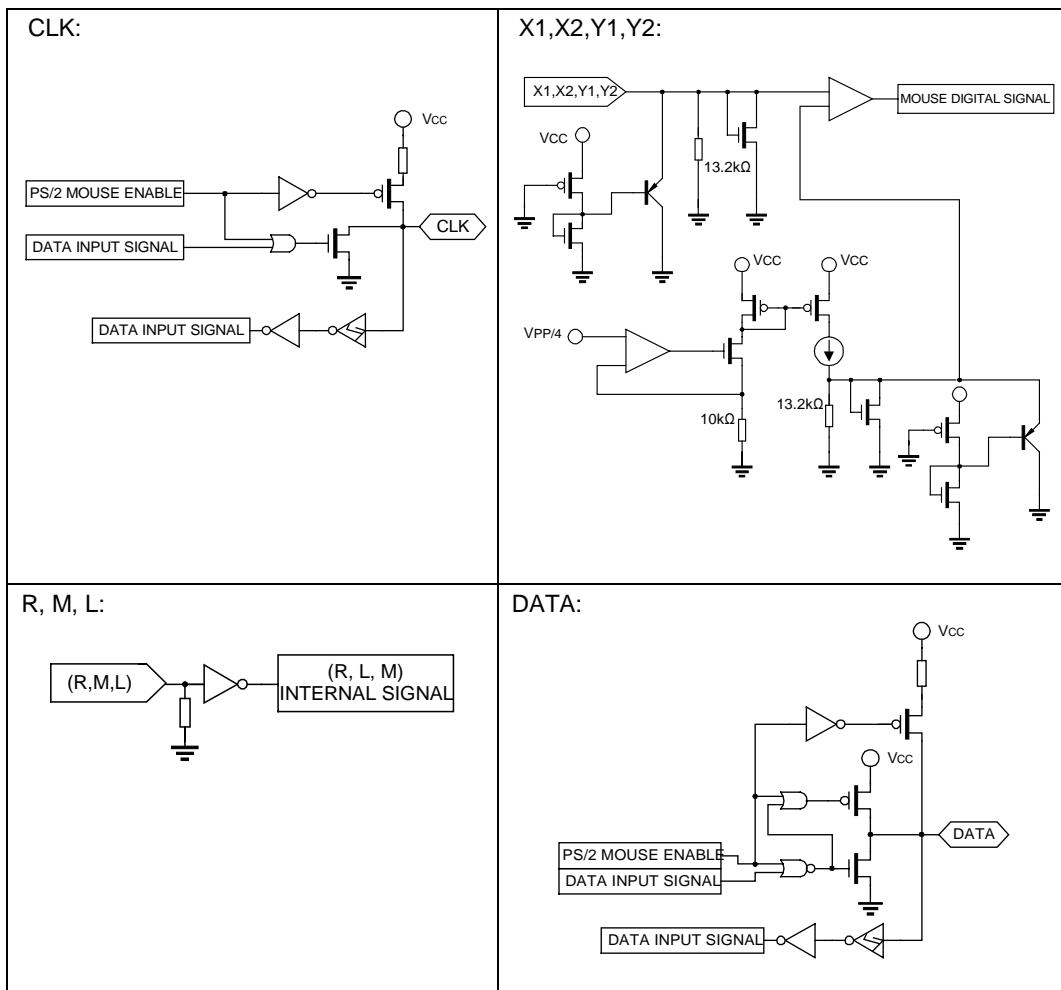

**APPLICATIONS CIRCUITS**

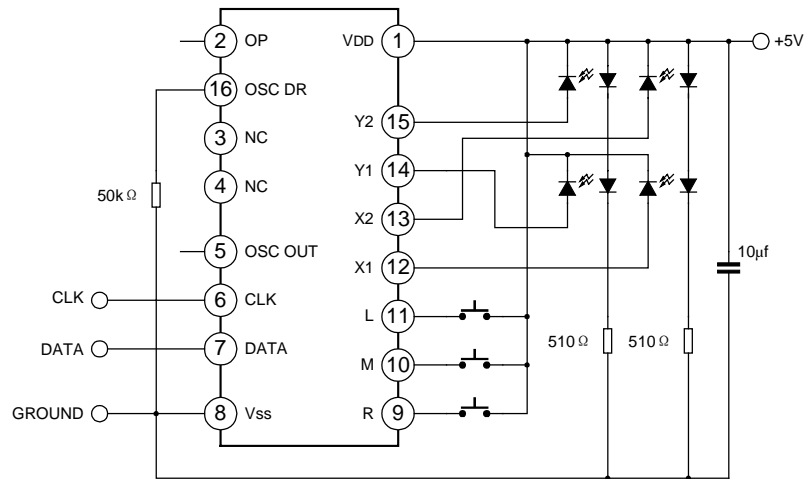

SC84502AP

## PACKAGE OUTLINE

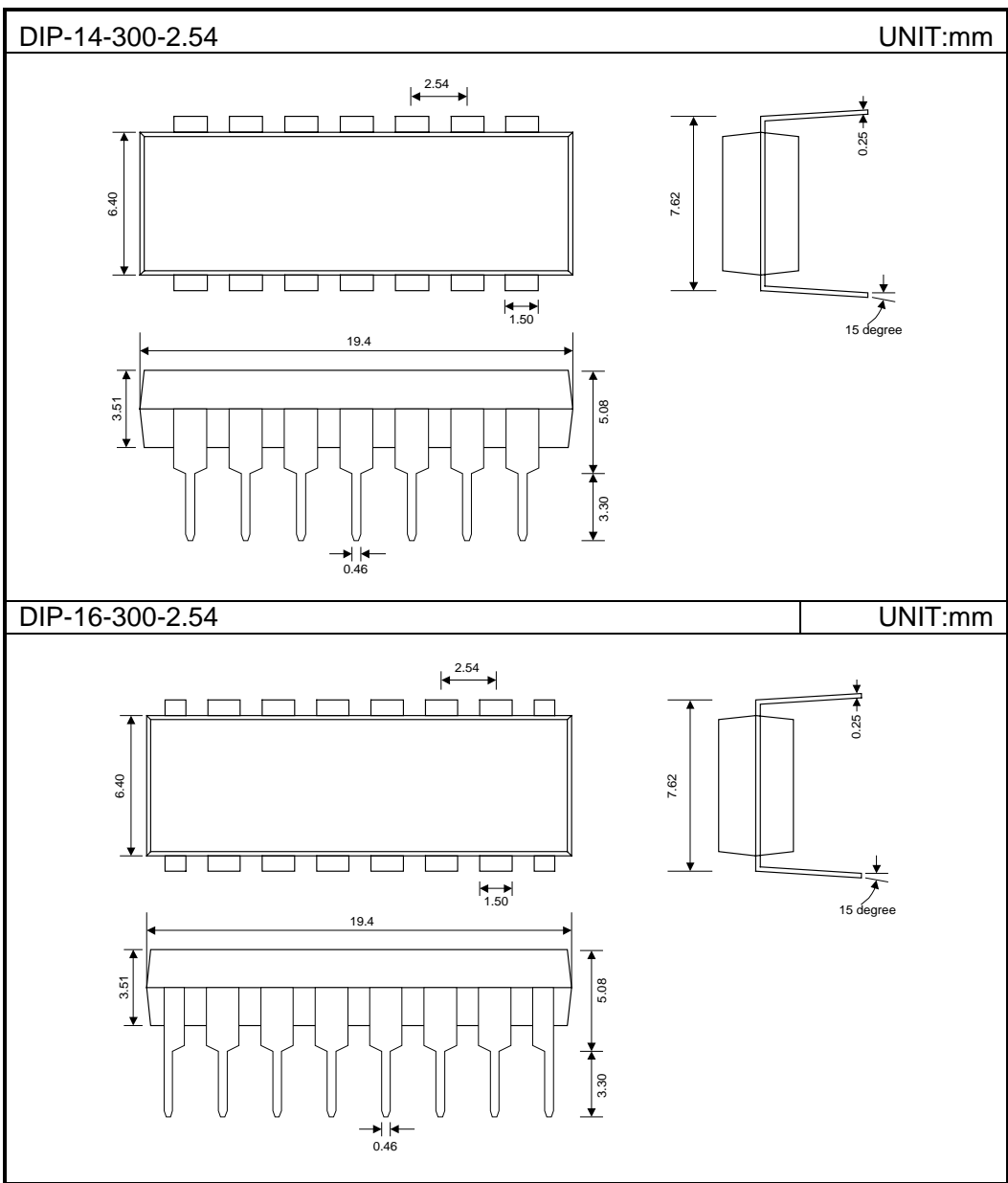

HANGZHOU SILAN MICROELECTRONICS JOINT-STOCK CO.,LTD

Rev: 1.0 2000.12.31