

# SONY CX20188/CXA1098Q

## □□ Dolby B-C Type Noise Reduction System

### Description

CX20188/CXA1098Q are ICs designed for use in Dolby B and C type noise reduction systems. These ICs offer complete stereo Dolby B and C type noise reduction with just one IC and a few external components. These devices provide inductorless spectral skewing circuits and excellent low distortion characteristics, and are suitable for use in high grade cassette decks and high grade automotive equipments.

### Features

- Spectral skewing circuits with inductorless structure
- Very low distortion (0.002% typ. 1 kHz  $\pm$ 10 dB in NR OFF)
- Dual channel processors in one chip
- Programmable input and output levels
- Low supply current (16 mA typ. in NR OFF)

### Structure

Bipolar silicon monolithic IC.

### Absolute Maximum Ratings ( $T_a=25^\circ\text{C}$ )

• Supply voltage	$V_{CC}$	22	V
• Operating temperature	$T_{opr}$	-30 to +85	$^\circ\text{C}$
• Storage temperature	$T_{stg}$	-55 to +150	$^\circ\text{C}$
• Allowable power dissipation			
	CX20188	$P_D$	2200 mW
	CXA1098Q	$P_D$	600 mW

### Package Outline

Unit: mm

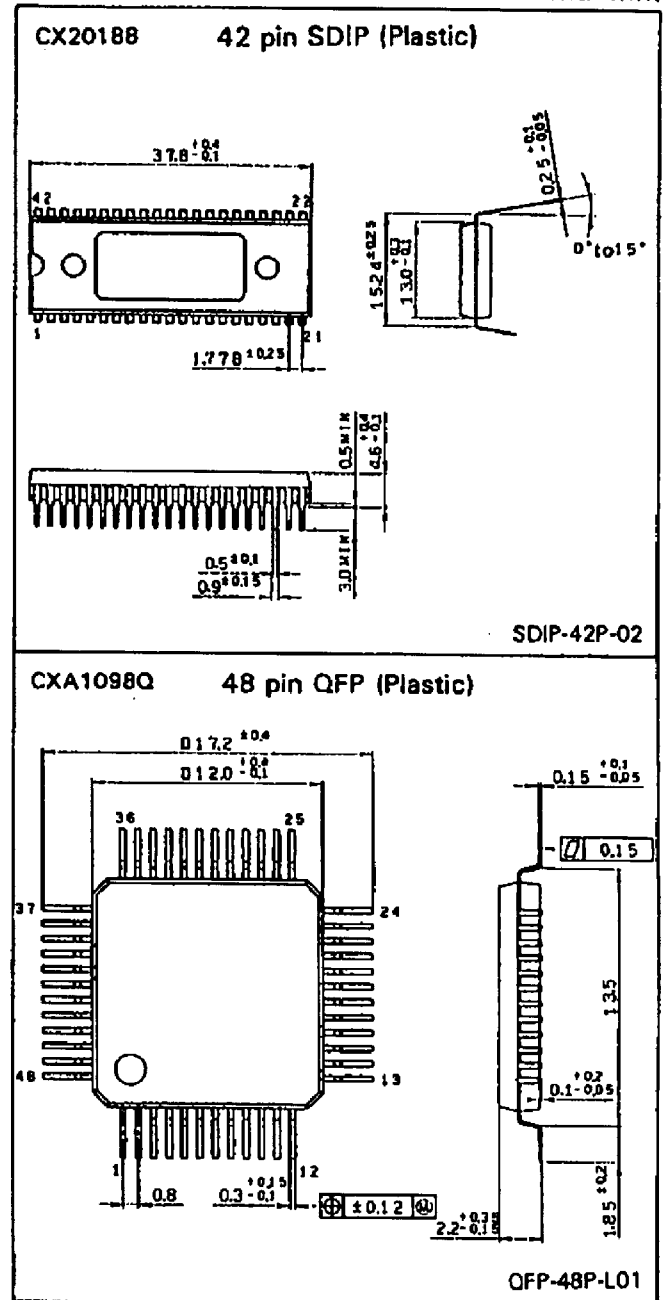

**Note)** These ICs are available only to the licensees of Dolby Laboratories Licensing Corporation from whom licensing and application information may be obtained. "Dolby" and double D symbols are trade marks of Dolby Laboratories Licensing Corporation.

### Block Diagram and Pin Configuration

www.datasheet4u.com

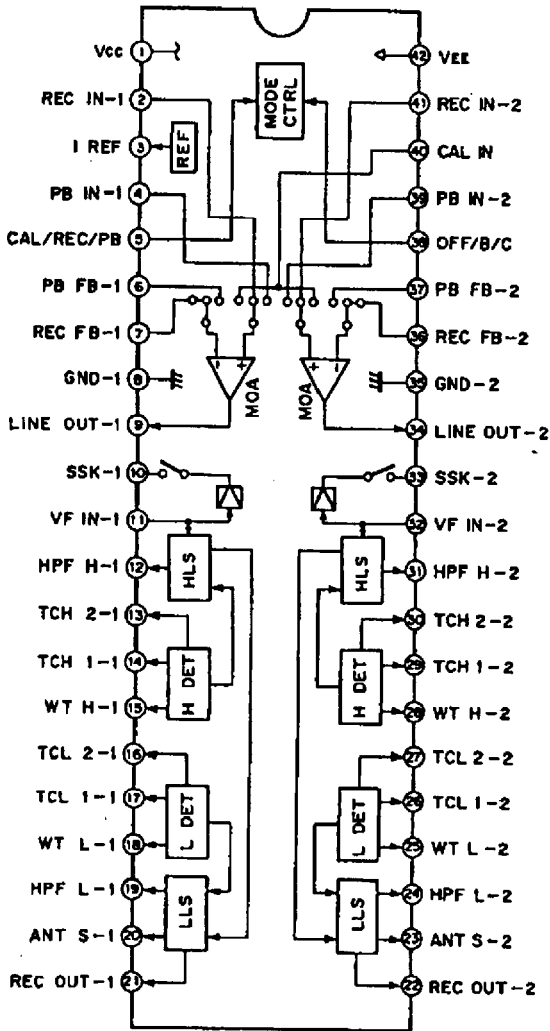

CX20188

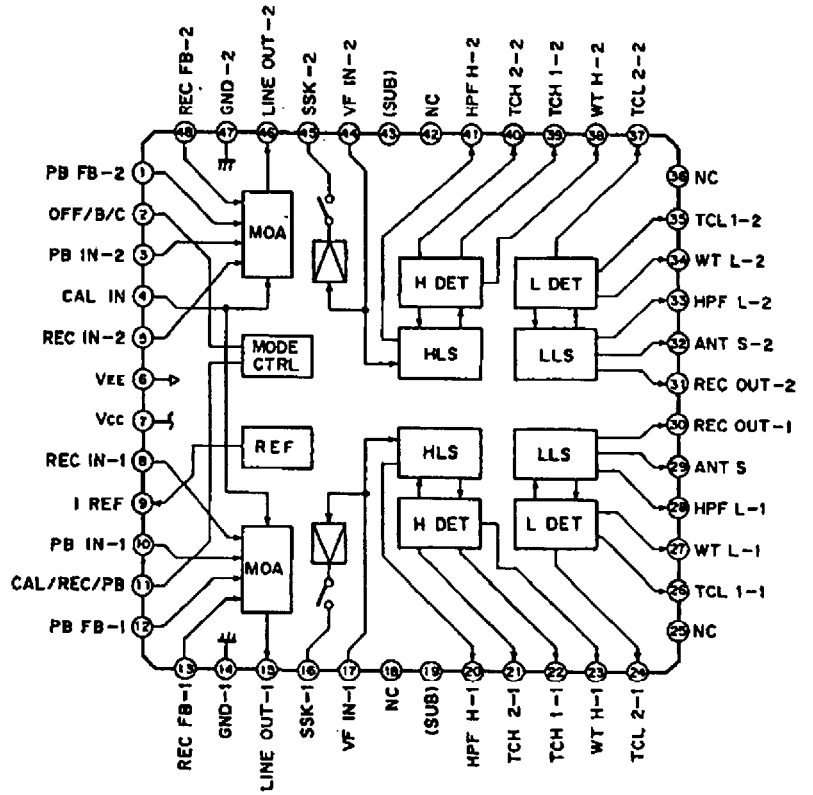

CXA1098Q

## Pin Description

CX20188 No.	CXA1098Q No.	Symbol	Description
1	7	Vcc	Positive power supply
2, 41	5, 8	REC IN	Recording input
3	9	I REF	Reference current source
4, 39	3, 10	RB IN	Playback input
5	11	CAL/REC/PB	Calibration/recording/playback switching
6, 37	1, 12	PB FB	Playback feedback
7, 36	13, 48	REC FB	Recording feedback
8, 35	14, 47	GND	With split supply: GND, with single supply: Vcc/2
9, 34	15, 46	LINE OUT	Line output (decode output)
10, 33	16, 45	SSK	Spectral skewing switch
11, 32	17, 44	VF IN	Encode circuit input
12, 31	20, 41	HPF H	HLS high-pass filter
13, 30	21, 40	TCH 2	HLS detector time constant 2
14, 29	22, 39	TCH 1	HLS detector time constant 1
15, 28	23, 38	WT H	HLS weighting
16, 27	24, 37	TCL 2	LLS detector time constant 2
17, 26	26, 35	TCL 1	LLS detector time constant 1
18, 25	27, 34	WT L	LLS weighting
19, 24	28, 33	HPF L	LLS high-pass filter
20, 23	29, 32	ANT S	Anti-saturation
21, 22	30, 31	REC OUT	Recording output (encode output)
38	2	OFF/B/C	Dolby NR off/B-type/C-type switching
40	4	CAL IN	Calibration input
42	6	V <sub>EE</sub>	With split supply: negative power supply, with single supply: GND

CX20188 Application Circuit

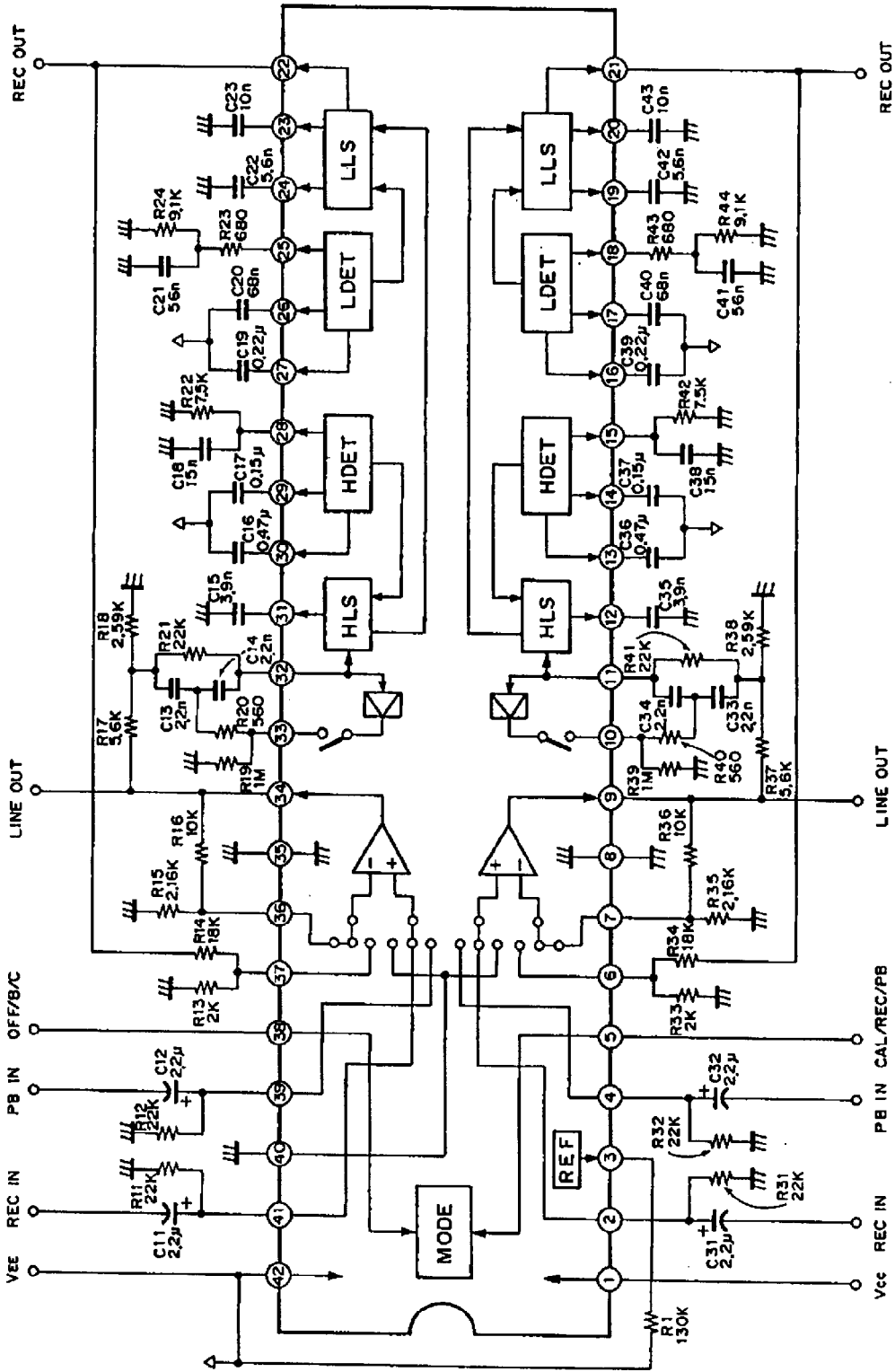

Note) For operation below 12V C20 and C40 should be 0.1 μF.

## Electrical Characteristics

Ta=25°C, Vcc=10V, VEE=-10V unless otherwise specified.  
Dolby Level: -10 dBm (=245 mVrms) at REC OUT

Characteristic	Symbol	Test Condition*1				Min.	Typ.	Max.	Unit
		R/P	NR	f(Hz)	Other Condition				
Operating voltage*2	Vopr	—	—	—	Split Single	±4.0 8.0	— —	±10.5 21.0	V V
Supply current*3	Icc	R	OFF	—	No Signal	12.0	16.0	21.0	mA
Encode characteristic (Boost)									
B-type (1)	B-R-1	R	B	500	-25dB	1.9	2.9	3.9	dB
(2)	B-R-2	R	B	2k	-25dB	6.0	7.0	8.0	dB
(3)	B-R-3	R	B	5k	-25dB	4.4	5.4	6.4	dB
(4)	B-R-4	R	B	10k	-40dB	9.7	10.4	11.4	dB
(5)	B-R-5	R	B	10k	0dB	-0.6	0.4	1.4	dB
C-type (1)	C-R-1	R	C	500	-60dB	15.0	16.2	17.4	dB
(2)	C-R-2	R	C	500	-25dB	8.0	9.2	10.4	dB
(3)	C-R-3	R	C	2k	-60dB	19.7	20.7	21.9	dB
(4)	C-R-4	R	C	2k	-25dB	6.2	7.4	8.6	dB
(5)	C-R-5	R	C	5k	-25dB	4.3	5.5	6.7	dB
(6)	C-R-6	R	C	10k	0dB	-4.7	-3.5	-2.3	dB
Frequency response	F-R	R	OFF	20k	Refer to 1 kHz	-0.5	0.0	0.5	dB
Signal handling*4	Vomax	R	OFF	1k	THD=1% at REC OUT	15.0	18.0	—	dB
Total harmonic distortion									
NR OFF	THD(OFF)	R	OFF	1k	+10dB	—	0.002	0.05	%
B-type	THD(B)	R	B	1k	+10dB	—	0.02	0.05	%
C-type	THD(C)	R	C	1k	+10dB	—	0.05	0.10	%
C-type encode S/N ratio	SN(CCIR)	R	C	—	Rg=5kΩ (CCIR/ARM)	60	64	—	dB
Crosstalk									
REC-PB	CT-1	P	OFF	1k	0dB	—	-100	-70	dB
PB-REC	CT-2	R	OFF	1k	0dB	—	-97	-70	dB
REC ch to ch	CT-3	R	OFF	1k	0dB	—	-86	-65	dB
PB ch to ch	CT-4	P	OFF	1k	0dB	—	-85	-65	dB

Characteristic	Symbol	Test Condition*1				Min.	Typ.	Max.	Unit
		R/P	NR	f(Hz)	Other Condition				
REC OUT Offset Voltage (C-type-OFF)	V <sub>off</sub>	R	C	—	—	-40	0	40	mV
Control Voltage									
"H" level	VC-H	—	—	—	—	3.0	—	V <sub>CC</sub>	V
"M" level	VC-M	—	—	—	—	-0.7	—	0.7	V
"L" level	VC-L	—	—	—	—	V <sub>EE</sub>	—	-3.0	V

- Note) \*1. 0 dB means the level which provides the Dolby level at the recording output in the noise reduction off mode.
- \*2. Modification of the external components value should be required for low voltage condition.
- \*3. Single supply operation.
- \*4. The reference level of the line output is 0 dBm (775 mVrms).

www.datasheet4u.com

Electrical Characteristics Test Circuit

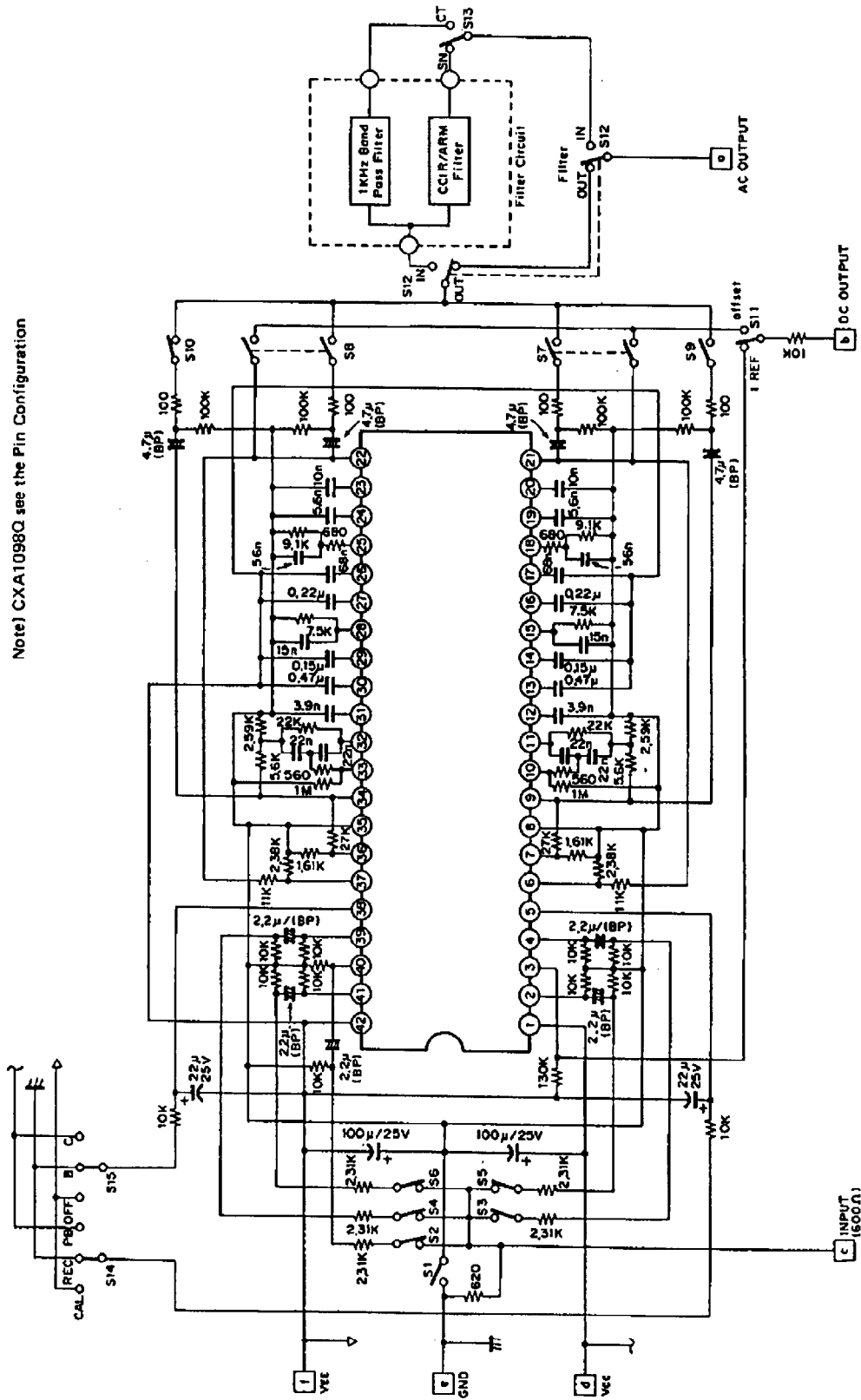

Quiescent current vs. Supply voltage

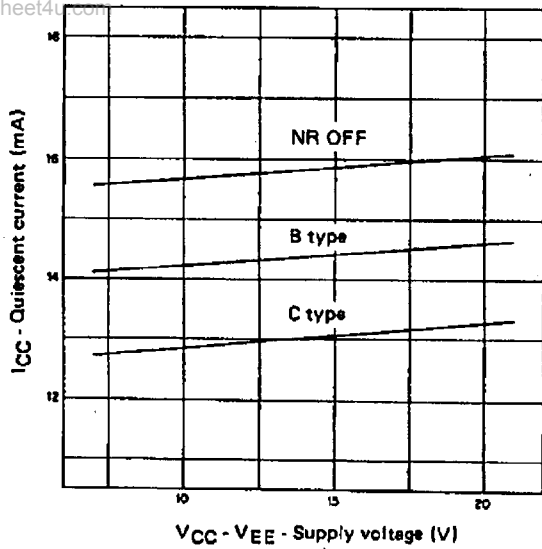

Supply current vs. Input level

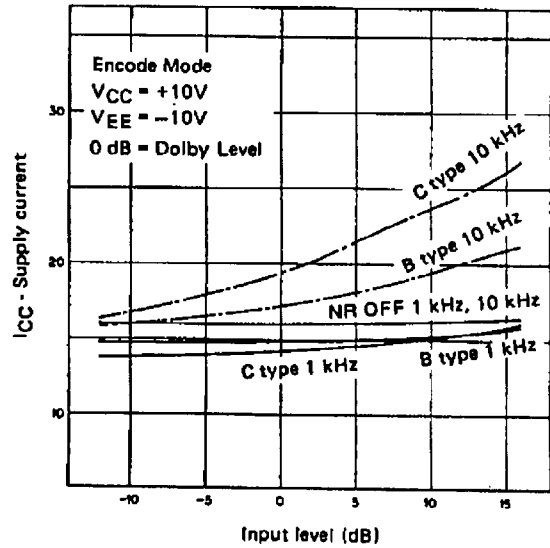

B type encode characteristics

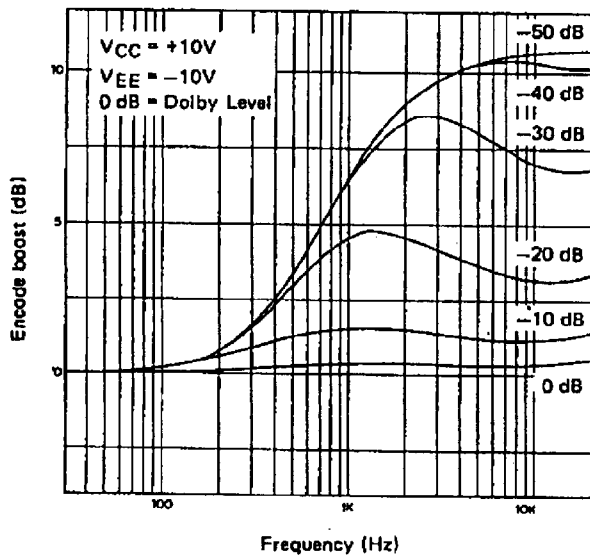

C type encode characteristics

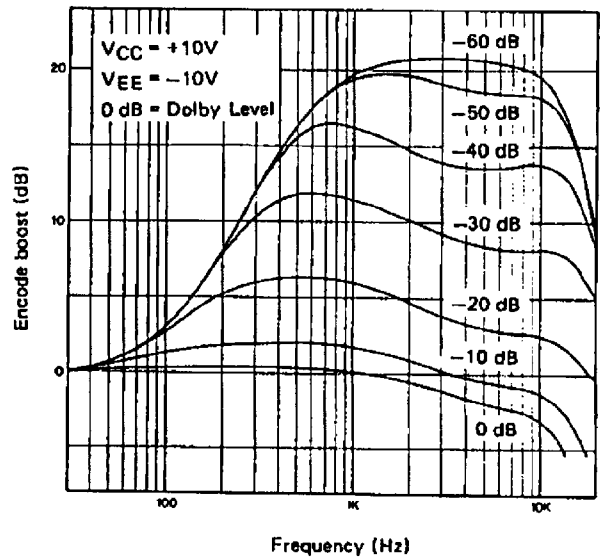



**B type temperature characteristics**

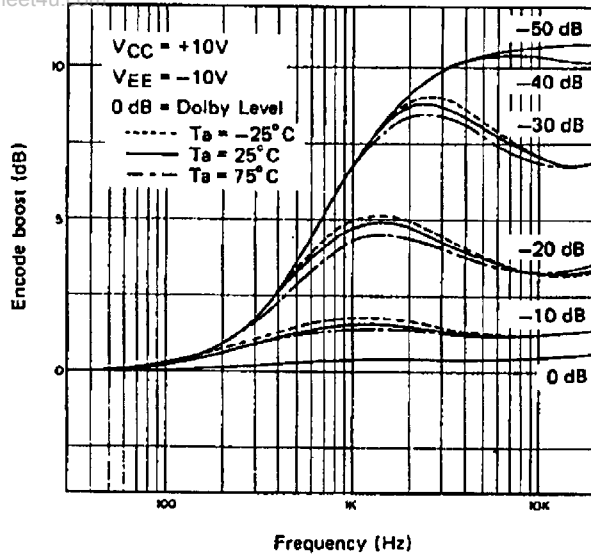

**C type temperature characteristics**

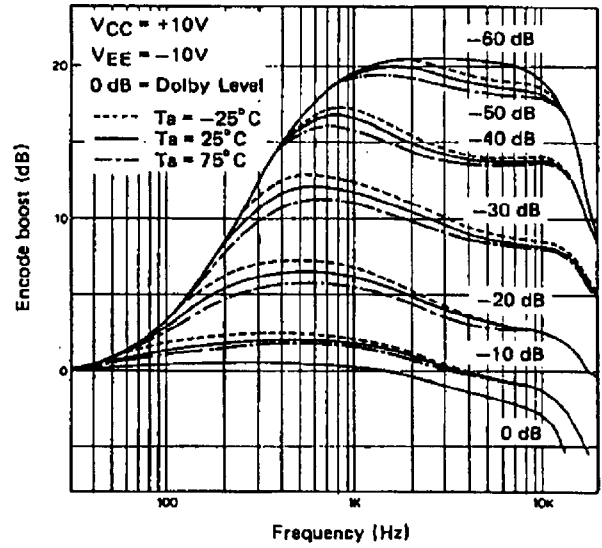

**NR OFF total harmonic distortion**

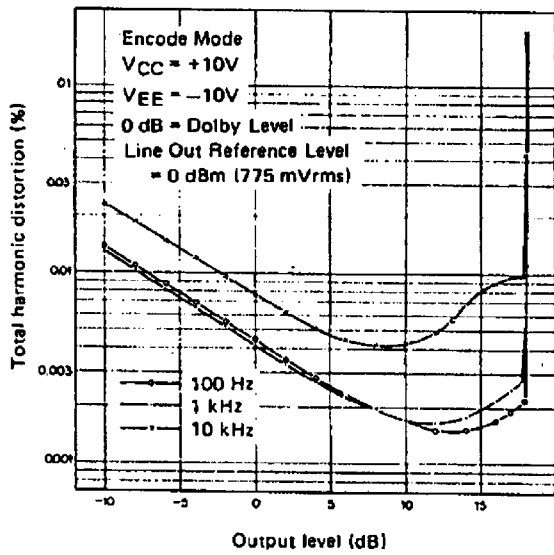

**B type total harmonic distortion**

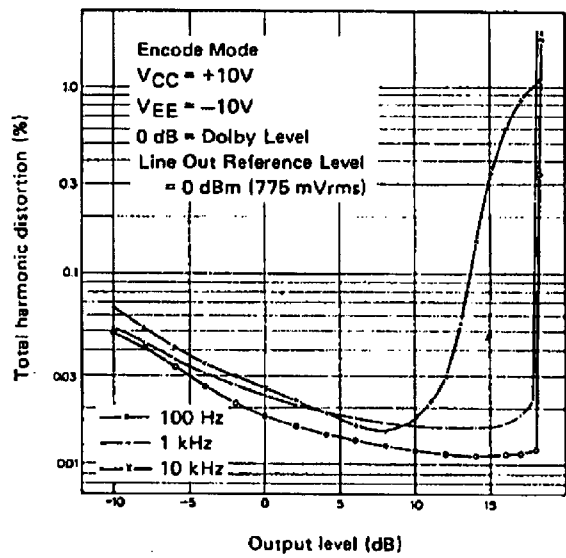

C type total harmonic distortion

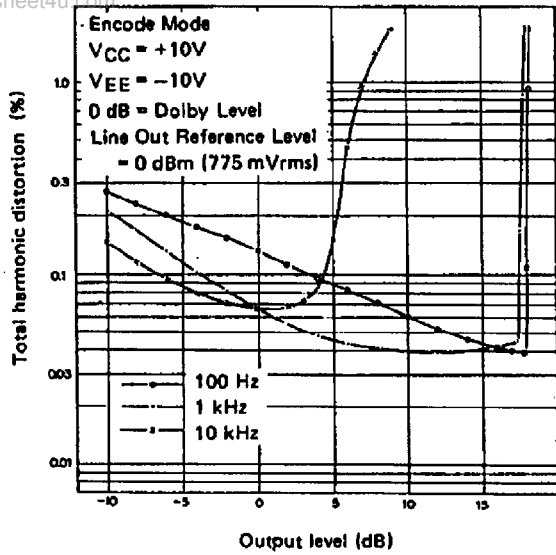

Drive capability

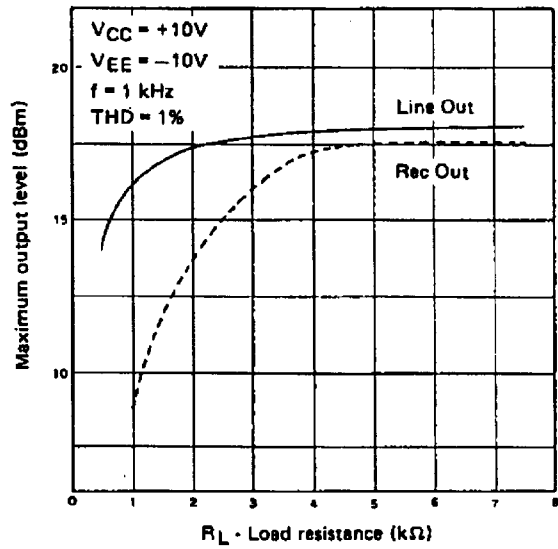

Maximum line output level

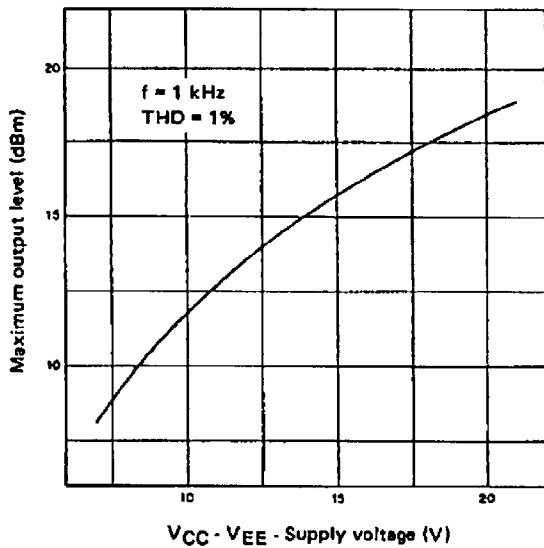

Recording output overload margin

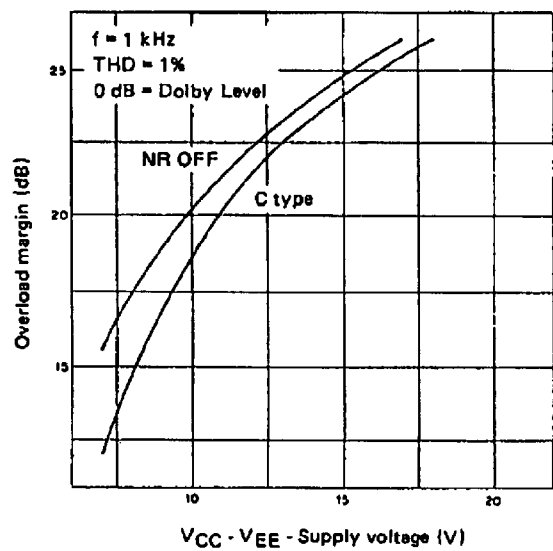

Channel to channel crosstalk

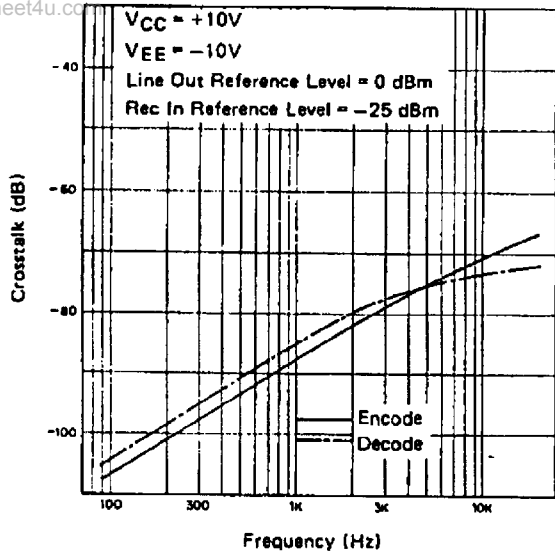

Recording and play back crosstalk

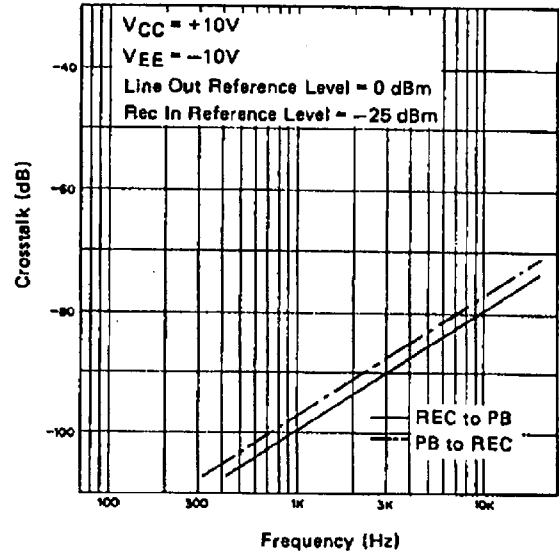

Control threshold voltage (1)

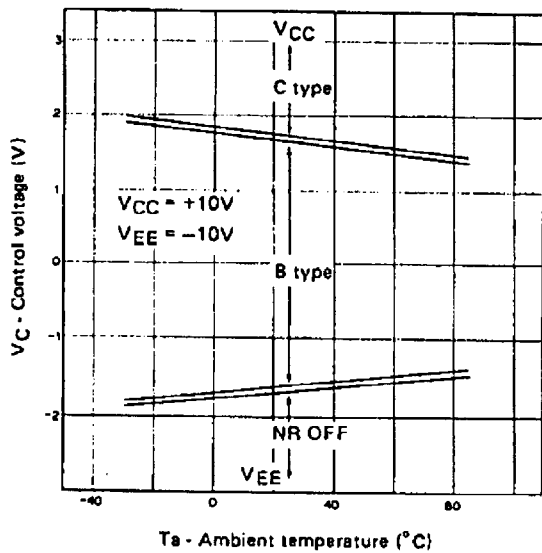

Control threshold voltage (2)

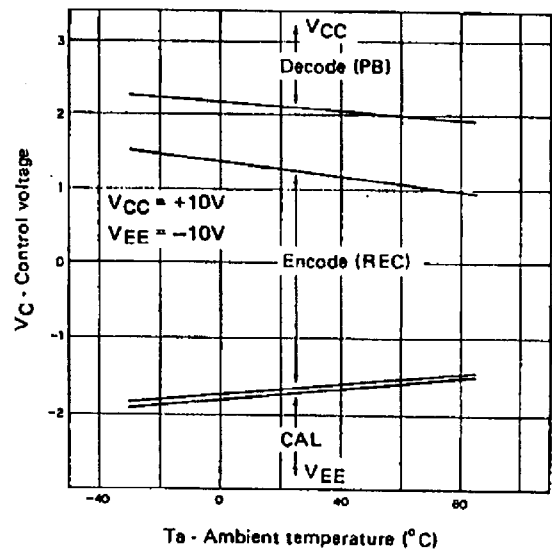

Ripple rejection ratio (1)

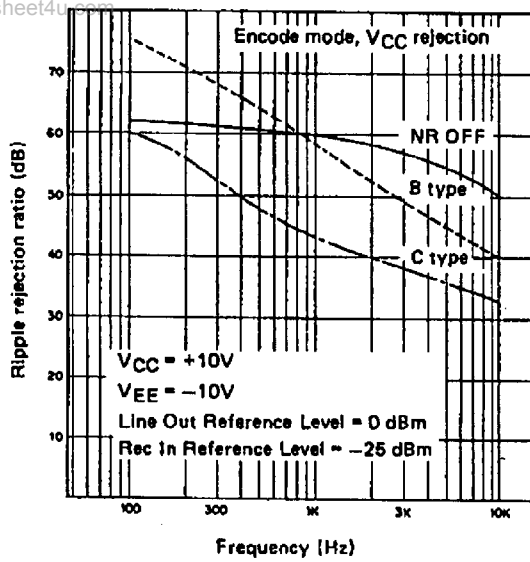

Ripple rejection ratio (2)

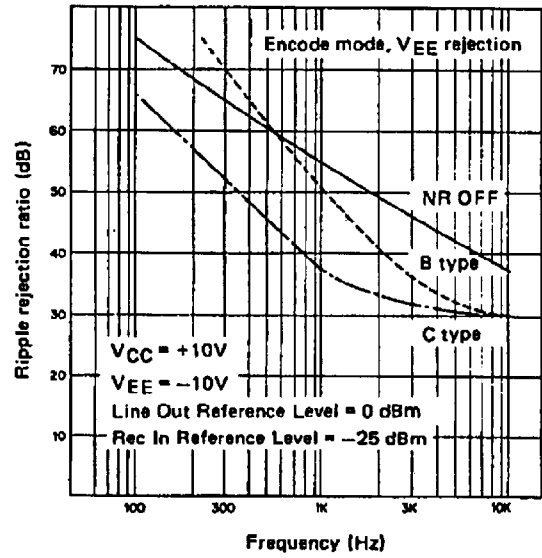

Ripple rejection ratio (3)

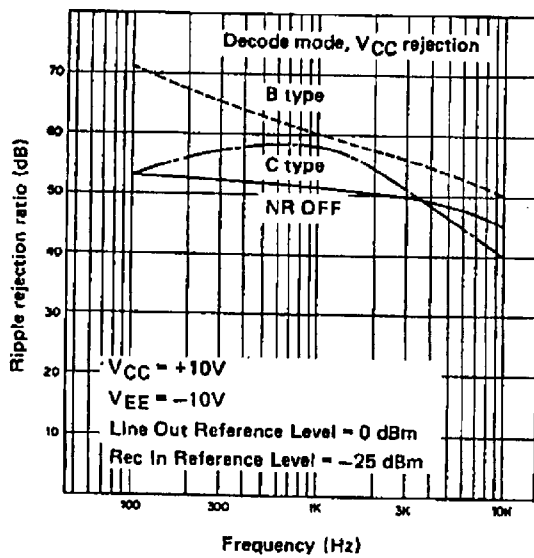

Ripple rejection ratio (4)

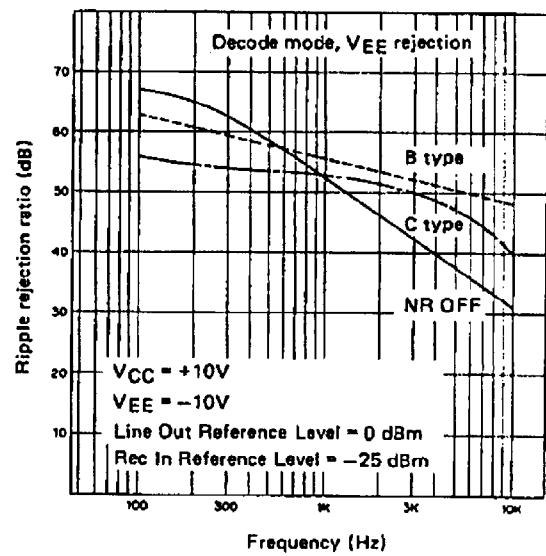

## Notes on Application

## 1) Power Supply

The CX20188/CXA1098Q are designed to operate on either single ended supply or split supply. The operation range of the supply voltage is

(a) Single ended supply operation: 8 to 21 V

(b) Split supply operation :  $\pm 4$  to  $\pm 10.5$  V

For the low supply voltage condition these devices require to change the capacitances of the low level stage detectors as shown in Fig. a-1.

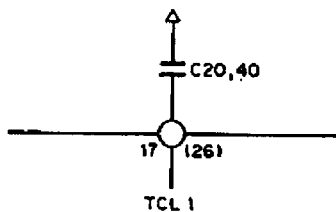

High voltage condition

above +12V or  $\pm 6$ V supply

C20, C40=68 nF

Low voltage condition

below +12V or  $\pm 6$ V

C20, C40=0.1  $\mu$ F

Fig. a-1

For the single ended supply operation these devices generate the signal grounds of half the supply voltage. Independent two signal grounds are provided for each channel. These pins should be connected bypass capacitors independently. External connection between the signal grounds may save the bypass capacitor, however, low frequency channel separation will degrade even though acceptable.

A usefull feature of these devices is the provision for programmable line output structure, which will permit an optimum overload margin for various supply conditions. The overload margin therefore depends on both of the supply voltage and the line output reference level. Table a-1 shows the maximum line output reference levels to satisfy overload margins of 12 dB and 15 dB. 12 dB of the overload margin is the minimum value specified by Dolby Laboratories.

Supply Voltage	Overload Margin	
	12dB	15dB
8V ( $\pm 4$ V)	-3.0dBm (548mVrms)	-6.0dBm (388mVrms)
10V ( $\pm 5$ V)	-0.5dBm (731mVrms)	-3.5dBm (518mVrms)
12V ( $\pm 6$ V)	1.5dBm (921mVrms)	-1.5dBm (652mVrms)
15V ( $\pm 7.5$ V)	3.5dBm (1.16Vrms)	0.5dBm (820mVrms)
20V ( $\pm 10$ V)	6.0dBm (1.55Vrms)	3.0dBm (1.09Vrms)

Table a-1 Maximum line output level

## 2) Operation mode control

The CX20188/CXA1098Q provide fully electronic switching circuits. The functions are controlled by DC voltage of the two control pins of CAL/REC/PB and OFF/B/C. The switching truth table are shown in Table a-2. The switching levels are as follows

## (a) Single ended supply operation

$$V_{cc} \cong V_H \cong V_{cc}/2+3V$$

$$V_{cc}/2+0.7V \cong V_M \cong V_{cc}/2-0.7V$$

$$V_{cc}/2-3V \cong V_L \cong GND$$

$V_{cc}/2$  is not mathematical half of the supply voltage but the potential of the signal ground.

## (b) Split supply operation

$$V_{cc} \cong V_H \cong 3V$$

$$0.7V \cong V_M \cong -0.7V$$

$$-3V \cong V_L \cong V_{EE}$$

CAL/REC/PB	VH	VM	VL
Function	PB (Decode)	REC (Encode)	CAL

OFF/B/C	VH	VM	VL
Function	C type	B type	NR OFF

Table a-2 Switching truth table

The CAL (Calibration) mode is provided for the recording level and frequency response calibration functions of high grade cassette decks. It may also be used as an input muting function also. This mode functions as the encode mode basically, and selects CAL pin for the input pin.

It is desirable to provide CR time constant circuits at CAL/REC/PB and OFF/B/C pins with time constant from 100 msec to 1 sec, which will reduce switching clicks effectively.

3) Reference Levels

Characteristics and specifications of the Dolby noise reduction processor are defined and measured with reference to the Dolby level. This particular level in these devices is -10 dBm (245 mVrms), and is measured at the Test Point (VF IN) or the recording output (REC OUT). The input and output reference levels, which provide the Dolby level at the Test Point or the recording output in the NR off mode, are programmable with the external circuit.

The CX20188/CXA1098Q provide inductorless spectral skewing circuits, which are composed of a bootstrapped bridges-T circuit as shown in Fig. a-2. Resistors of R17 and R18 compose an attenuation circuit to determine the line output (LINE OUT) reference level. In Fig. a-2 the attenuation factor H<sub>ssk</sub> is defined as

$$H_{ssk} = 20 \cdot \text{Log} (1 + R17/R18)$$

The line output reference level becomes

$$\text{Line output reference level} = H_{ssk} - 10 \text{ [dBm]}$$

The parallel combination of R17 and R18 has to maintain a constant value to keep the specified spectral skewing characteristics. This particular resistance is 1.78 kΩ for 2.2 nF capacitance of C13 and C14. Table a-3 shows the useful combinations of R17 and R18 for various applications.

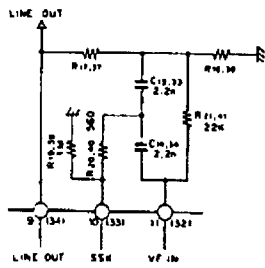

Fig. a-2

R17	R18	Line Output Reference Level	Supply Voltage
5.6kΩ	2.7kΩ	-0.2dBm (753mVrms)	≥11.0V (±5.5V)
4.3kΩ	3kΩ	-2.3dBm (596mVrms)	≥9.0V (±4.5V)
3.3kΩ	3.9kΩ	-4.7dBm (452mVrms)	≥8.0V (±4.0V)

Table a-3 Spectral skewing circuit attenuation

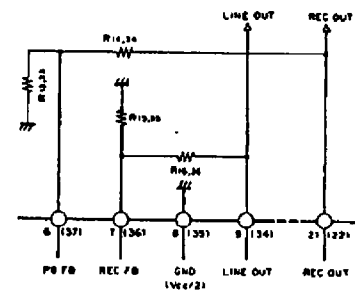

Fig. a-3

The reference level of the recording input (REC IN) and the play back input (PB IN) depend on the feedback factors of an operational amplifier MOA, which is an input switchable operational amplifier. In the recording mode the operational amplifier MOA composes the fixed gain amplifier with the feedback path of R15 and R16, and drives the encode processor. In the play back mode the output of the encode processor (REC OUT) is fed back to the inverting input (PB FB) of the operational amplifier. The transfer function of the operational amplifier therefore becomes the inverted transfer function of the encode processor, and operates as the decoder. The reference levels of the recording input (REC IN) and the play back input (PB IN) are as follows

$$\text{Recording input reference level} = \text{Line output reference level} - H_{REC} \text{ [dBm]}$$

$$\text{Play back input reference level} = -10 - H_{PB} \text{ [dBm]}$$

where, H<sub>REC</sub> and H<sub>PB</sub> are the feedback factors in the encode mode and decode mode respectively.

$$H_{REC} = 20 \cdot \text{Log} (1 + R16/R15)$$

$$H_{PB} = 20 \cdot \text{Log} (1 + R14/R13)$$

Increase of the recording input sensitivity will degrade the overall noise reduction effect, which has to satisfy more than 17 dB of the specified minimum value. A recommendable recording input sensitivity is approximately  $-25$  dBm (44 mVrms). The range of the allowable play back input sensitivity will be limited by the open loop gain and the phase margin in the play back mode. A recommendable range of the play back input sensitivity is from  $-32$  dBm (19 mVrms) to  $-25$  dBm (44 mVrms).

#### 4) Notes on Application

Application circuits of Fig. a-5 and Fig. a-6 show capacitors of C25, C26, C45 and C46 in the LLS and HLS weighting circuits.

We guarantee the encode error specified in the data sheet without these capacitors. However, we recommend to include the capacitors for three head cassette decks in which independent processors are provided for encode and decode processors respectively.

For example, combination of a device with positive error and a device with negative error may generate significant frequency response error, even if the devices are within specified limit. These capacitors will improve the encode error due to offset voltages of the level detectors.

(a) Encode Processor with Split Supply (Fig. a-5) will reduce the encode error.

Supply voltage	: $\pm 8$ Vtyp. ( $\pm 6$ to $\pm 10$ V)
Line output level	: $-0.2$ dBm (753 mVrms)
Recording output level	: $-10$ dBm (245 mVrms)
Recording input level	: $-24.3$ dBm (47 mVrms)

This circuit is suitable for three head cassette decks.

(b) Decode Processor with Split Supply (Fig. a-6)

Supply voltage	: $\pm 8$ Vtyp. ( $\pm 6$ to $\pm 10$ V)
Line output level	: $-0.2$ dBm (753 mVrms)
Play back input level	: $-30$ dBm (25 mVrms)

This circuit is suitable for three head cassette decks.

(c) Switchable Processor with Split Supply (Fig. a-7)

Supply voltage	: $\pm 8$ Vtyp. ( $\pm 6$ to $\pm 10$ V)
Line output level	: $-0.2$ dBm (753 mVrms)
Recording output level	: $-10$ dBm (245 mVrms)
Recording input level	: $-24.3$ dBm (47 mVrms)
Play back input level	: $-30$ dBm (25 mVrms)

This circuit is suitable for high grade two head cassette decks.

(d) Switchable Processor with Single Ended Supply (Fig. a-8)

Supply voltage	: $+14$ V typ. (9 to 20V)*
Line output level	: $-2.3$ dBm (596 mVrms)
Recording output level	: $-10$ dBm (245 mVrms)
Recording input level	: $-24.6$ dBm (46 mVrms)
Play back input level	: $-30$ dBm (25 mVrms)

This circuit is most appropriate for general applications.

\* **Note)** Change C20 and C40 to  $0.1 \mu\text{F}$  when  $V_{CC}$  is below  $+12$ V.



## (e) Decode Processor with AUX input (Fig. a-9)

Supply voltage	: +9V typ. (8 to 20V)*
Line output level	: -4.7 dBm (452 mVrms)
Recording output level	: -10 dBm (245 mVrms)
AUX input level	: -30.2 dBm (23 mVrms)
Play back input level	: -30 dBm (25 mVrms)

www.datasheet4u.com

This unique application providing AUX input is suitable for car stereo players and car stereo cassette decks. AUX input will be useful for a tuner input. CAL/REC/PB switching operates as the switching of AUX/Tape. The operation in the AUX input mode is independent of the switch position of OFF/B/C. When AUX input is unnecessary, C2, C11, C31, R3, R11, R31, R15, R16, R35 and R36 can be omitted. Refer to Fig. a-6.

\* **Note**) Change C20 and C40 to 68 nF when Vcc is upon +12V.

## (f) Application for Dubbing Cassette Decks

The CX20188/CXA1098Q simplify the structure of dubbing decks. Conventional dubbing decks utilize the Dolby processors commonly for two systems. Problems occur on the dubbing mode of a Dolby NR encoded tape. Listeners will be forced to monitor non-decoded sound. This device offers a simple solution, which is to utilize the recording output signal in the play back mode as shown in Fig. a-4. In the dubbing mode the processor operates as a decode (play back) mode. The monitor (line output) signal from the deck A will be decoded if necessary, however, the deck B will record directly without decoding. This special application is possible because this device generates a non-decoded signal at the recording output in the decode mode even though it operates on the B type or C type NR.

## Application for Dubbing Deck

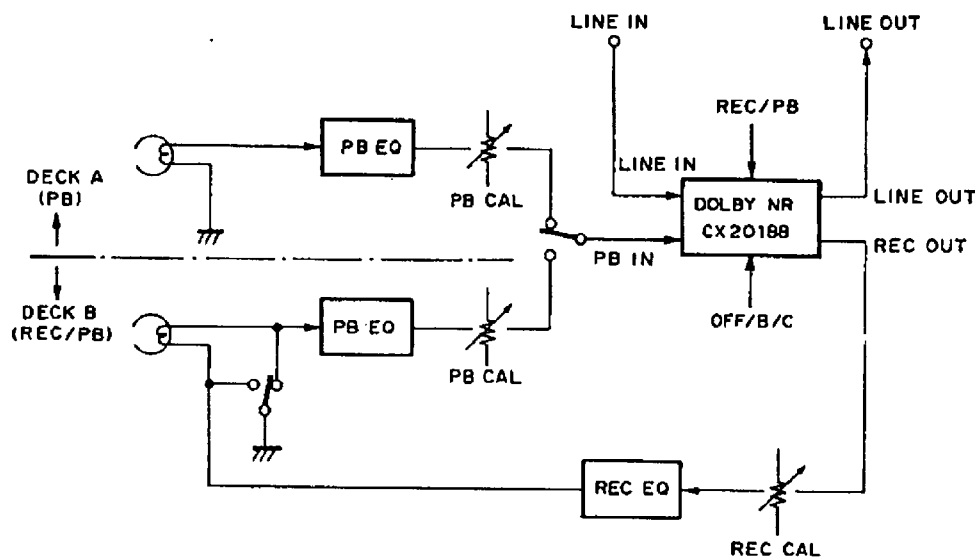
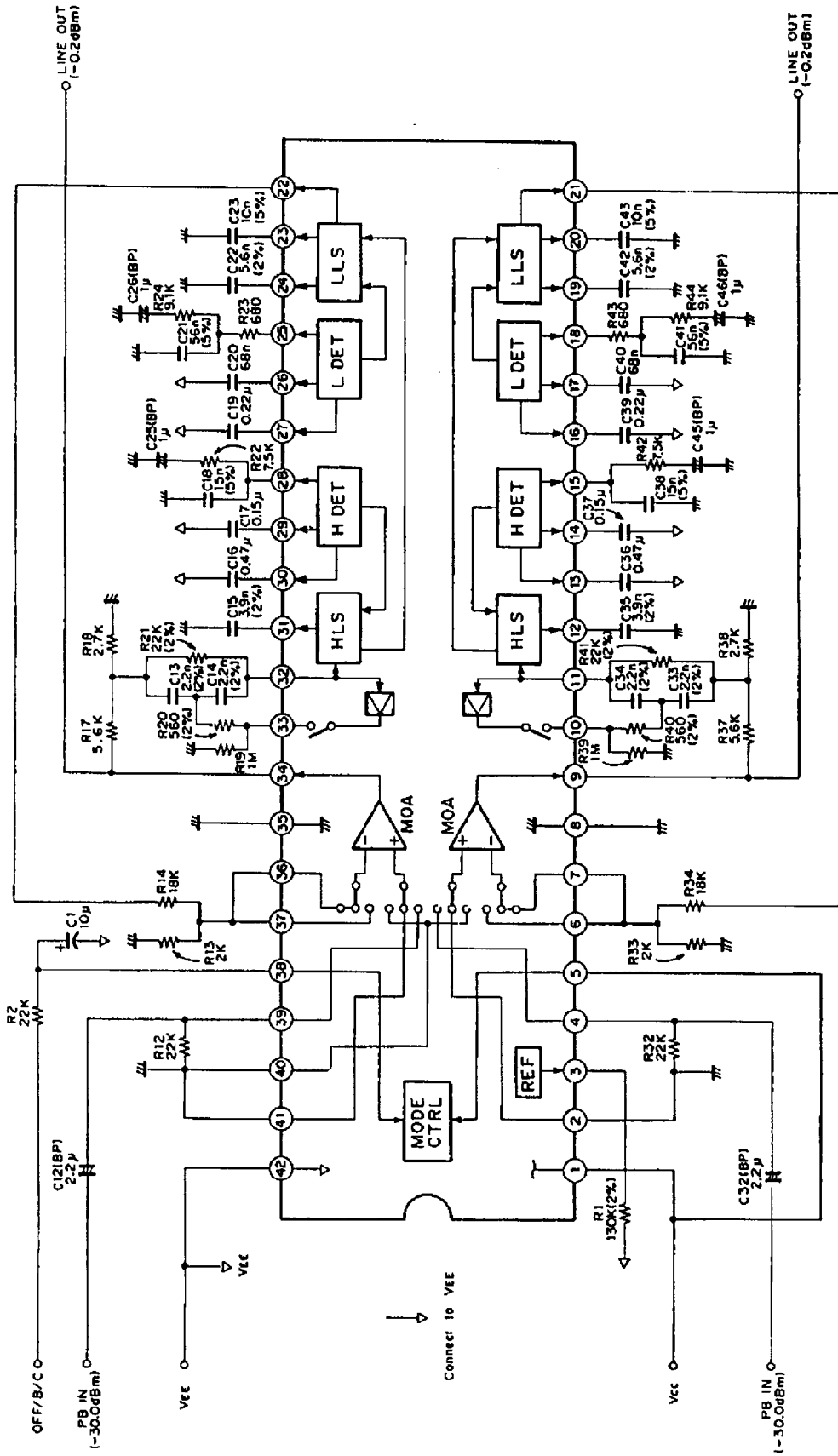

Fig. a-4



Decode Processor with Split Supply for 3 Head Cassette Deck



- Note)
1. Resistor tolerances are  $\pm 5\%$  unless otherwise specified
  2. Capacitor tolerances are  $\pm 10\%$  unless otherwise specified except for coupling capacitors
  3. CXA1098Q refer to the pin configuration

Fig. a-6

Switchable Processor with Split Supply

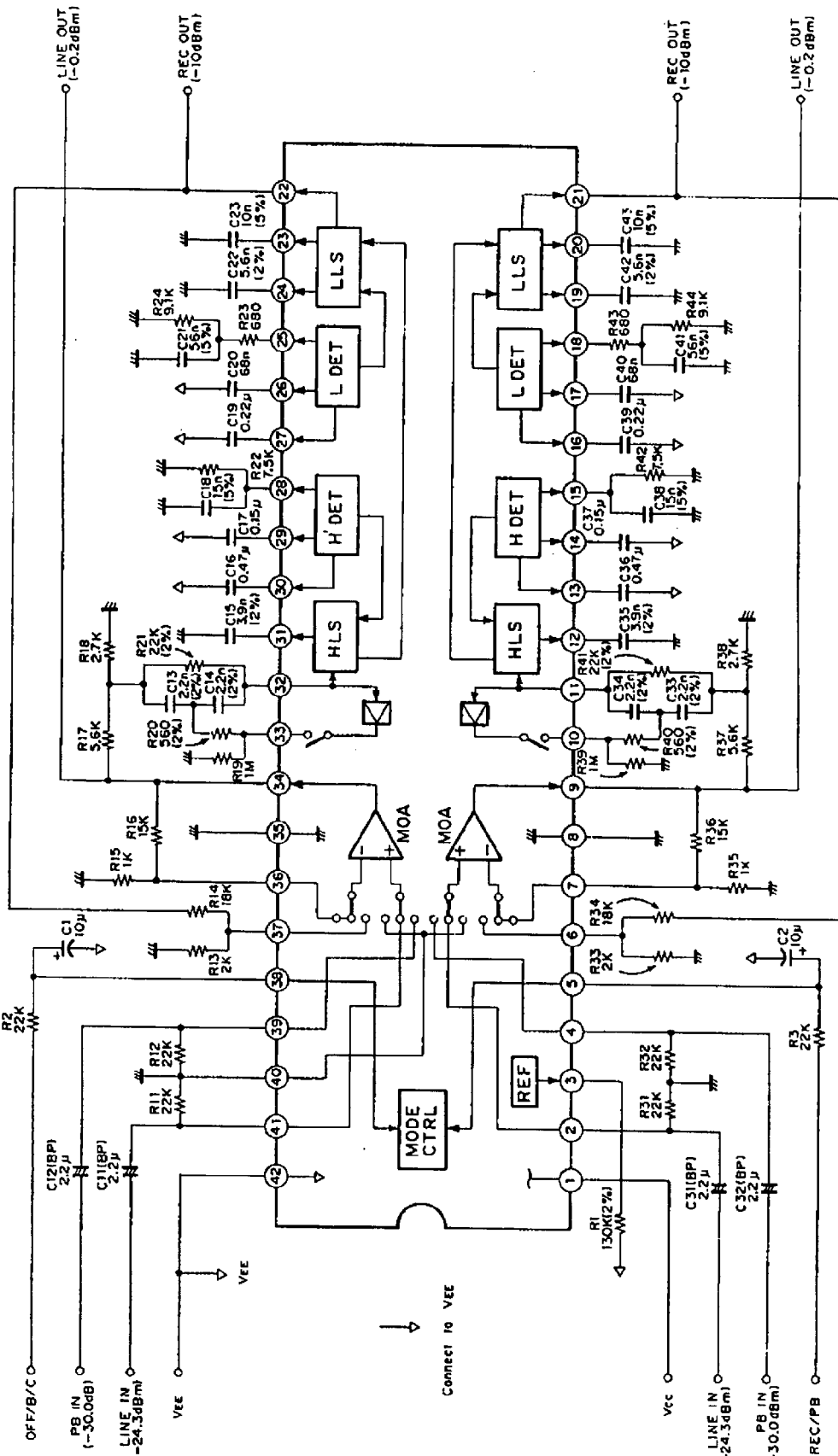

- Note)
1. Resistor tolerances are  $\pm 5\%$  unless otherwise specified
  2. Capacitor tolerances are  $\pm 10\%$  unless otherwise specified except for coupling capacitors
  3. CXA1098Q refer to the pin configuration

Fig. a-7

Switchable Processor with Single Supply

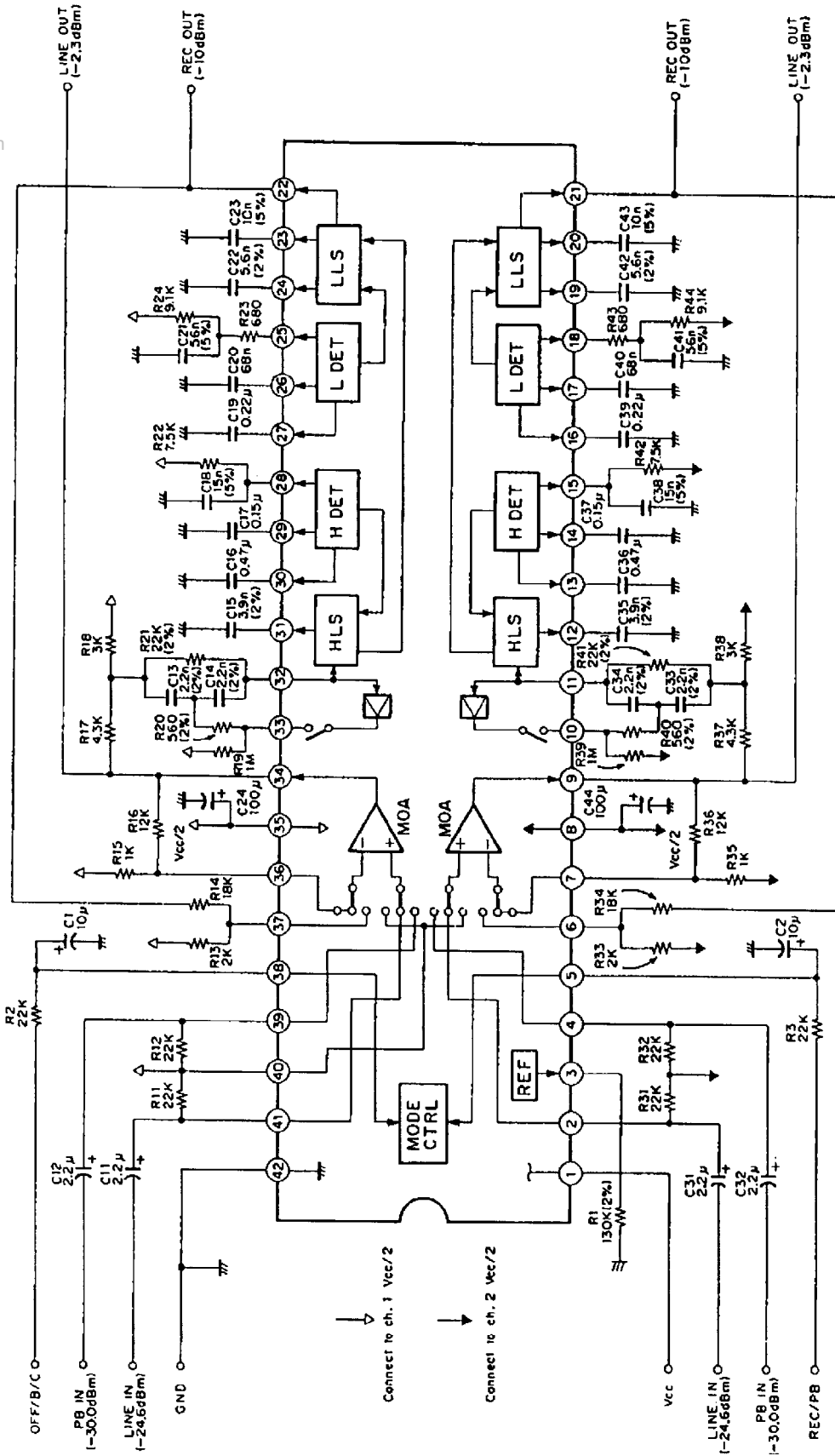

- Note)
1. Resistor tolerances are  $\pm 5\%$  unless otherwise specified
  2. Capacitor tolerances are  $\pm 10\%$  unless otherwise specified except for coupling capacitors
  3. CXA1098Q refer to the pin configuration

Fig. a-8

Decode Processor with AUX Input for Car Stereo Players

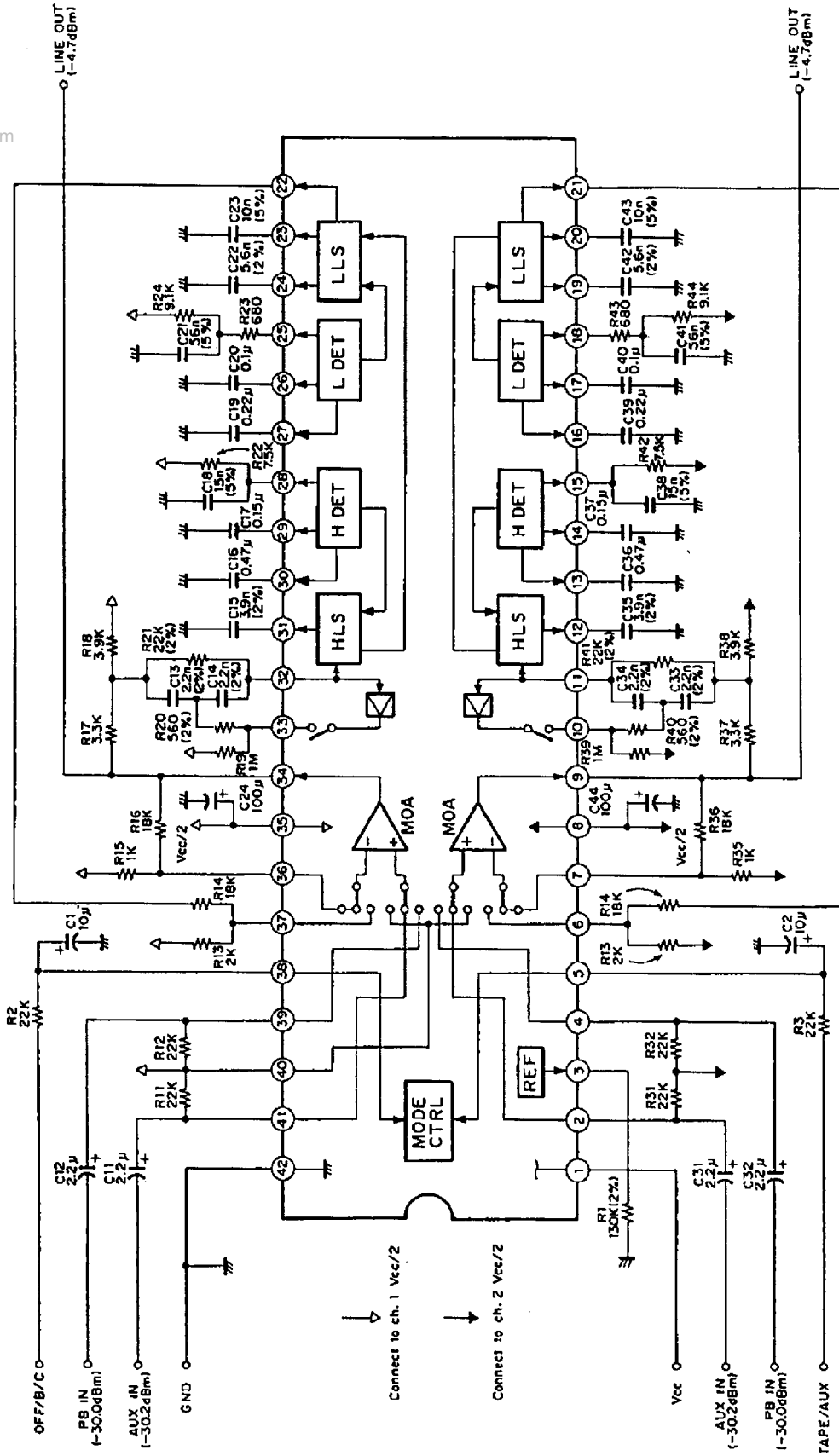

- Note)
1. Resistor tolerances are  $\pm 5\%$  unless otherwise specified
  2. Capacitor tolerances are  $\pm 10\%$  unless otherwise specified except for coupling capacitors
  3. CXA1098Q refer to the pin configuration

Fig. a-9