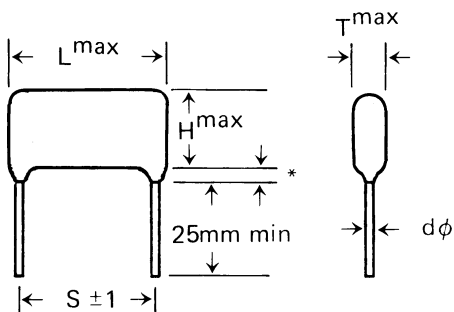

METALLIZED POLYPROPYLENE CAPACITOR

TYPE 2114

NON-INDUCTIVE, EXTENDED FOIL, EPOXY DIP COATED

*2mm max. for $L > 20\text{ mm}$ *1.5mm max. for $L \leq 20\text{ mm}$

APPLICATION

Wave-form shaping, delay & timing circuits for communications industries. Filtering and noise suppression in all commercial and industrial equipment.

FEATURES

- High reliability.
- Low losses and low ESR.
- Specials available upon request.

GENERAL SPECIFICATION

- OPERATING TEMPERATURE:**
-40°C to 85°C
- VOLTAGE RANGE:**
250, 400 and 630 VDC.
- CAPACITANCE RANGE:**
0.01 to 2.2 Mfd.
- DIELECTRIC STRENGTH:**
150% of rated voltage for 5 sec.
- CAPACITANCE TOLERANCE:**
±5%, ±10% and ±20%
- INSULATION RESISTANCE:**
C < .33 Mfd. R • 30,000 Meg. Ohm at 25°C
C • .33 Mfd. R • 10,000 Meg. Ohm x Mfd.
- DISSIPATION FACTOR:**
0.2% max. at 1 KHz 25°C (Typical 0.1%)
0.2% max. at 10 KHz for .01 Mfd. < C - 0.1 Mfd.
0.3% max. at 10 KHz for 0.1 Mfd. < C - 1.0 Mfd.

Part Number Example: See Page F.2

MAXIMUM PULSE RISE TIME (DV/DT) V/μSEC

VDC \ S	10.0	15.0	22.5	27.5
250	11	7	4	3
400	20	10	5.5	5
630	30	15	8	7

L	13.0	18.0	26.0	31.0
S	10.0	15.0	22.5	27.5
dφ	0.6	0.8	0.8	0.8

VDC \ Mfd	250 VDC				400 VDC				630 VDC			
	L	T	H	S	L	T	H	S	L	T	H	S
0.01	13.0	5.0	9.0	10.0	13.0	5.0	9.0	10.0	13.0	5.5	9.5	10.0
0.015	13.0	5.0	9.0	10.0	13.0	5.0	9.5	10.0	13.0	6.5	10.5	10.0
0.022	13.0	5.0	9.0	10.0	13.0	5.5	10.5	10.0	13.0	7.0	11.5	10.0
0.033	13.0	5.5	9.0	10.0	13.0	6.5	11.0	10.0	18.0	7.0	11.5	15.0
0.047	13.0	5.5	9.5	10.0	13.0	7.5	12.5	10.0	18.0	8.5	13.5	15.0
0.068	13.0	6.0	10.5	10.0	18.0	6.5	12.5	15.0	18.0	9.5	15.5	15.0
0.1	13.0	7.0	11.0	10.0	18.0	7.5	13.5	15.0	26.0	8.5	15.5	22.5
0.15	18.0	7.0	12.0	15.0	26.0	7.5	14.5	22.5	26.0	9.5	17.5	22.5
0.22	18.0	7.5	12.5	15.0	26.0	8.5	15.5	22.5	31.0	10.0	17.0	27.5
0.33	18.0	8.5	14.0	15.0	26.0	10.0	17.5	22.5	31.0	13.0	21.5	27.5
0.47	26.0	8.5	15.0	22.5	31.0	10.0	18.0	27.5	31.0	15.5	24.5	27.5
0.68	26.0	9.5	17.0	22.5	31.0	12.5	21.5	27.5				
1.0	26.0	12.0	20.5	22.5	31.0	15.0	24.0	27.5				
1.5	31.0	13.0	20.5	27.5								
2.2	31.0	15.0	24.0	27.5								

PART NUMBERING SYSTEM

Ex. 914-250/104 K 10

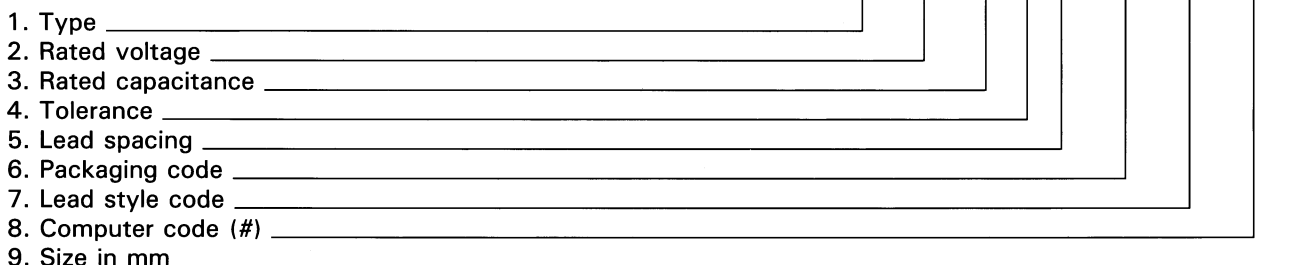

* If applicable

More ex.
 IF FORMED TO 5mm L/S 914-250/104K10B1/5
 IF CUT & FORMED TO 5mm L/S 914-250/104K10B5/5
 IF CUT & FORMED TO 5mm L/S & 3mm L/L .. 914-250/104K10B1/5#1
 (#1=one deviation from std ex.: L/L)

DESCRIPTION

- Describes the construction and the dielectric type.
- Rated voltage, (three digits) Ex. 050=050v, 250=250v, 1K0=1000v. 1K5=1500v
- Rated capacitance, (three digits). Ex. 102 = 1000pf = .001 μ f
 The first two digits represent significant figures and the last digit is number of zeros to follow,
 472 = 4700pf = .0047 μ f
 103 = 10000pf = .01 μ f
 104 = 100000 = .1 μ f
- Tolerance (one digit).

C	D	F	G	H	I	J	K	M	N	P	V	Z
± 0.25 pf	± 0.5 pf	$\pm 1.0\%$	$\pm 2.0\%$	$\pm 2.5\%$	$\pm 3.0\%$	$\pm 5.0\%$	$\pm 10\%$	$\pm 20\%$	$\pm 30\%$	+ ∞ -0	+20 -10	+80 -20

- Lead Spacing (in mm) showing significant digits without decimals.
- Packaging code: (TR = Tape and Reel.) (TA = Tape and Ammo.) (- = Bulk.)
- Lead Style code. Note: previous character must be a letter, hence, for bulk packaging use the letter B.
- Computer code.
- Size shown in mm.

Long leads				Cut leads			
straight long leads/non-forming	inside forming without cut	outside forming without cut	kink with out cut	non-forming with cut	inside forming with cut	outside forming with cut	kink with cut
0	1	2	3	4	5	6	7

Straight lead length portion = 25mm MIN.

Straight lead length portion = 5mm \pm 1

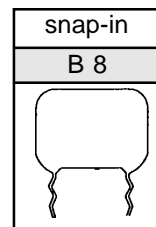
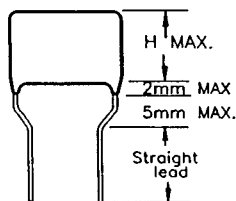

Due to the continued improvement of capacitor manufacturing technology other sizes and values, not described in this catalog, may now be available, please contact Factory or Area Representative for latest data.