

TPS816(F)

Lead Free Product

Photo-electric Switches

Office Equipment such as Photocopiers, Printers and Fax Machines

Unit: mm

The TPS816(F) is an Si photo-IC for digital output. It incorporates a photodiode, amp, waveform shaper, LED driver and sync detector in a single chip.

Use of sync optical modulation makes the IC ideal for applications in external light.

- Housed in compact side-view epoxy resin package
- High resistance to external light due to sync optical modulation: $E_X = 3000 \text{ lx (min)}$
- High-sensitivity: $EHL = 1 \mu\text{W}/\text{mm}^2 \text{ (max)}$
- Wide operating temperature range: $T_{opr} = -30^\circ\text{C to } 85^\circ\text{C}$
- High LED output current and low-level output current:

$$I_{LED} = 70 \text{ mA (Ta = T}_{opr})$$

$$I_{OL} = 16 \text{ mA (Ta = T}_{opr})$$

- Digital output (pull-up resistor included) : Low-level output for light input
- TPS816(F) package resin impermeable to visible light

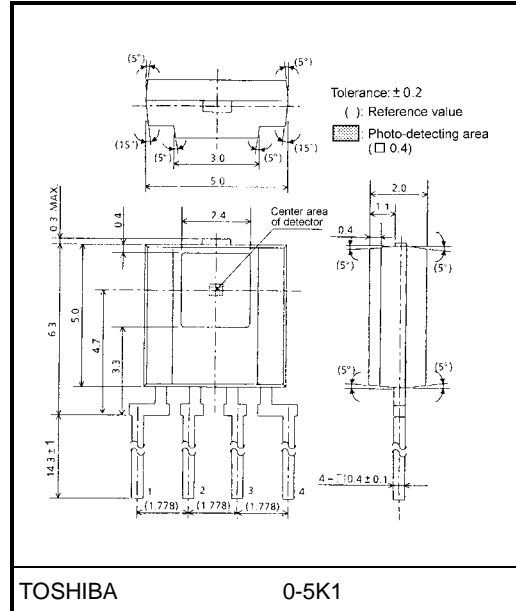

Weight: 0.3g (typ.)

Block Diagram

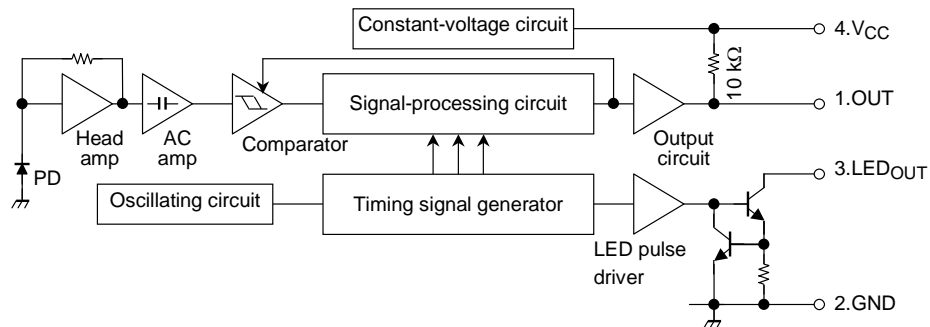

Maximum Ratings (Ta = 25°C)

Characteristics	Symbol	Rating	Unit
Supply voltage	V _{CC}	7	V
Output voltage	V _{OUT}	≤ V _{CC}	V
Output current (Ta = Topr)	I _{OUT}	16	mA
LED output voltage	V _{LED}	≤ V _{CC}	V
LED pulse forward current (Ta = Topr)	I _{LED}	70	mA
Operating temperature	T _{opr}	-30~85	°C
Storage temperature	T _{stg}	-40~100	°C
Soldering temperature (5s) (Note 1)	T _{sol}	260	°C

Note 1: Solder under the lead stopper.

Electrical and Optical Characteristics (V_{CC} = 5 V, Ta = 25°C)

Characteristics		Symbol	Test Condition	Min	Typ.	Max	Unit
Supply voltage		V _{CC}	—	4.5	5	5.5	V
Supply current		I _{CC}	V _{OUT} , V _{LED} left open	—	4	7	mA
Output	High-level output voltage	V _{OH}	E = 0	4.9	5	—	V
	Low-level output voltage	V _{OL}	I _{OL} = 16 mA, E = 2 μW/nm ² (Note 2)	—	0.15	0.4	V
LED output	Low-level output voltage	V _{LED}	I _{LED} = 70 mA (peak)	1.05	1.35	1.65	V
	Pulse cycle	T _C	(Note 3)	64	130	220	μs
	Pulse width	T _W	(Note 3)	4	8	13.7	μs
	Duty ratio	T _W /T _C	—	—	6	10	%
Peak sensitivity wavelength		λ _p	—	—	900	—	nm
Propagation characteristics	H → L threshold radiant incidence	E _{HL}	No visible light (Note 2)	—	0.6	1.0	μW/mm ²
	L → H threshold radiant incidence	E _{LH}		—	0.4	0.8	
	Hysteresis	E _{LH} /E _{HL}	—	0.45	0.65	0.8	—
	Propagation delay time (L → H)	t _{pLH}	(Note 4)	—	400	670	μs
	Propagation delay time (H → L)	t _{pHL}		—	400	670	
Permissible luminosity		E _X	E = 2 μW/nm ² (Note 2, 5)	3000	—	—	lx

Note 2: The signal light source is an infrared LED with λ_p = 940 nm.

Note 3: The LED output waveform measurement circuit and waveform are as follows:

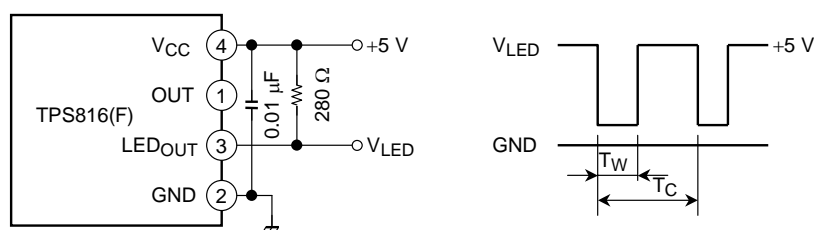

Note 4: The switching time measurement circuit and waveform are as follows:

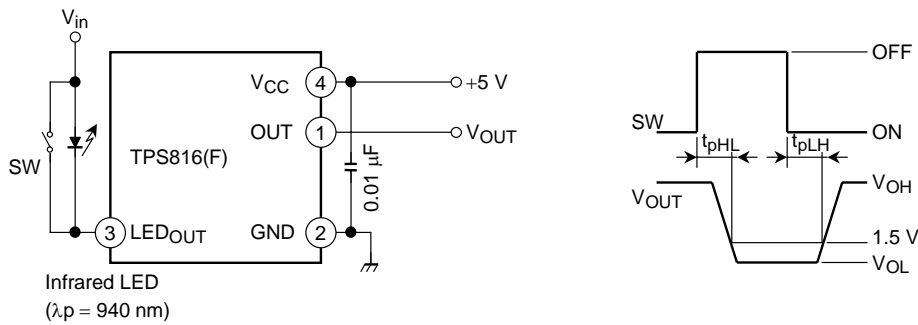

Note 5: Measurement of permissible external luminance

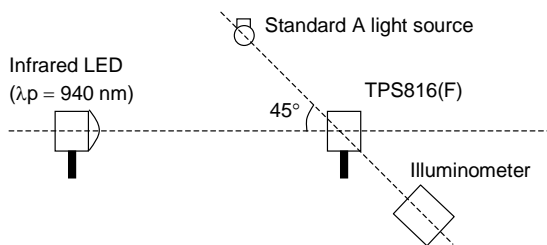

Measure the luminance limit at which the device operates normally.

The light used is a CIE Standard A light source (a standard tungsten bulb with a color temperature of 2856°K).

Handling Precautions

- When using the device with an LED, use an infrared LED. Note that light with a wavelength of 800 nm or less cannot be detected.
- Do not use the device in an environment where the external light is 3000 lx or more, as this may prevent the device from working properly.
- At power-on the internal circuit takes about 100 μs to stabilize. During this period the output signal is unstable and may change. Design the circuit so that no signal is output during this period.
- The photo-IC has a highly sensitive amp built in. To stabilize the power line, insert a bypass capacitor of up to 0.01 μF between VCC and GND, close to the device.
- If the LED is directly connected to the LEDOUT pin, excessive current will flow in the LED, severely degrading the optical output. Be sure to insert a limiting resistor to prevent excessive current flow in the LED.
- When forming the leads, bend each lead under the lead stopper. Soldering must be performed after the leads have been formed.
- Soldering must be performed under the stopper.

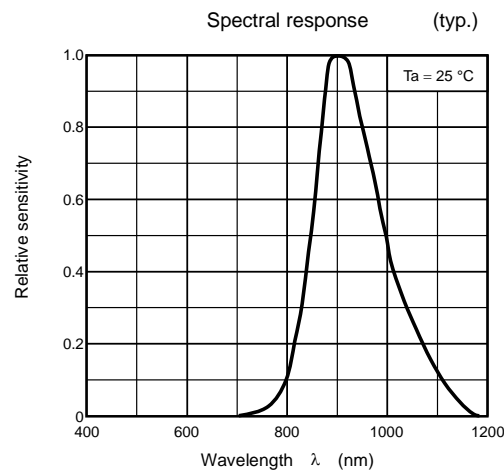
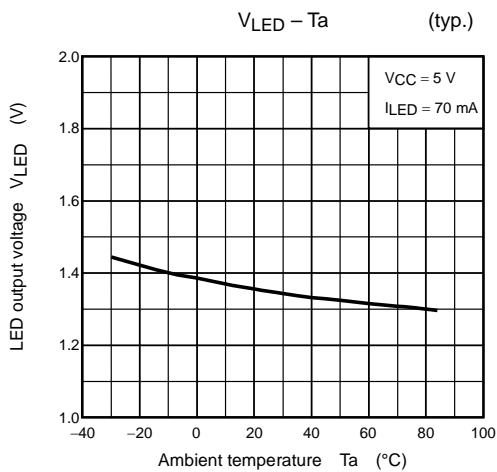
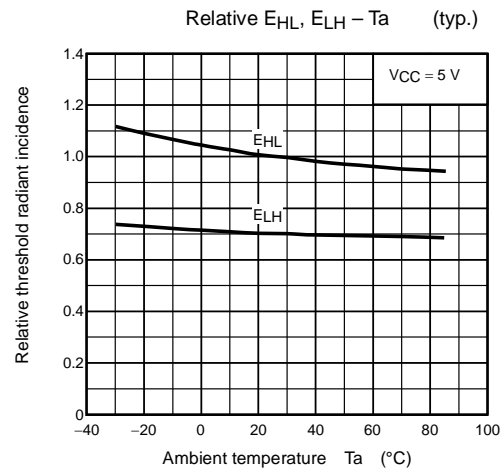
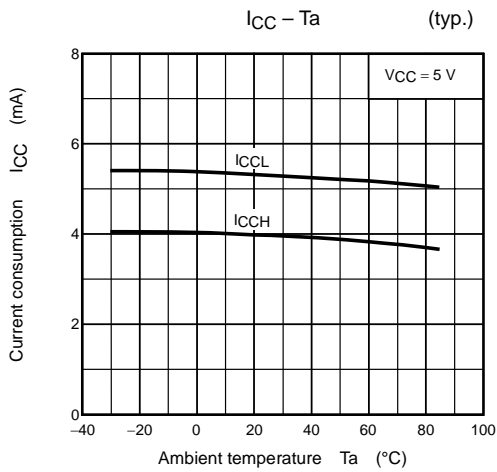
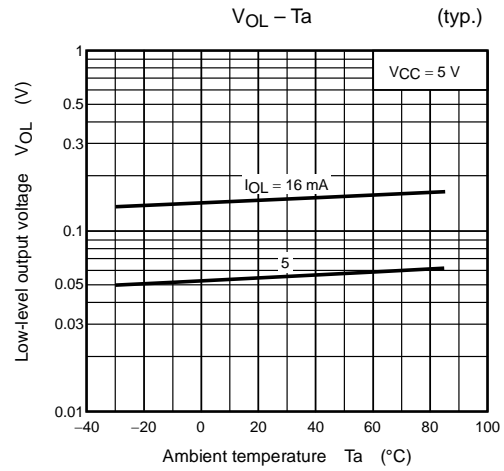
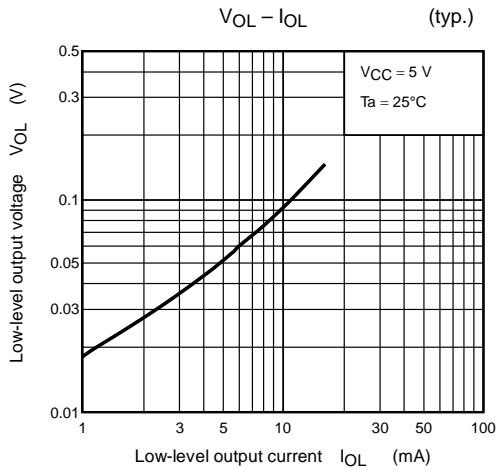

Radiation pattern - vertical direction (typ.)

Ta = 25°C

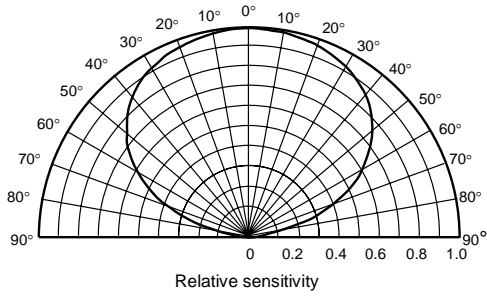

Radiation pattern - horizontal direction (typ.)

Ta = 25°C

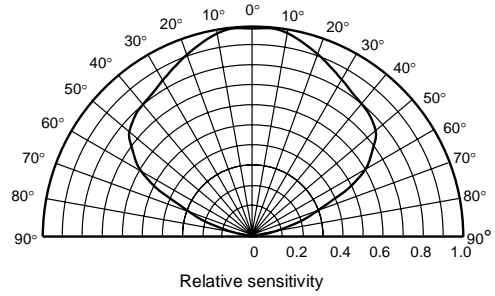

$I_E - d$ (typ.)

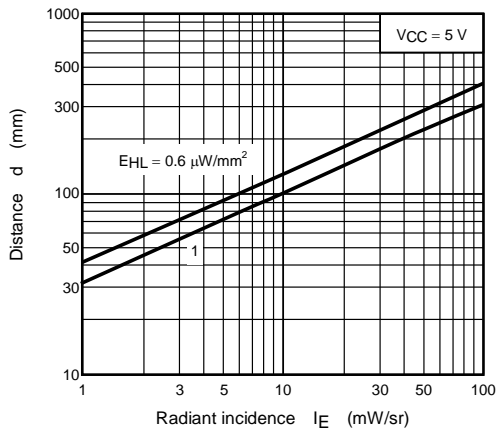

RESTRICTIONS ON PRODUCT USE

030619EBA

- The information contained herein is subject to change without notice.
- The information contained herein is presented only as a guide for the applications of our products. No responsibility is assumed by TOSHIBA for any infringements of patents or other rights of the third parties which may result from its use. No license is granted by implication or otherwise under any patent or patent rights of TOSHIBA or others.
- TOSHIBA is continually working to improve the quality and reliability of its products. Nevertheless, semiconductor devices in general can malfunction or fail due to their inherent electrical sensitivity and vulnerability to physical stress. It is the responsibility of the buyer, when utilizing TOSHIBA products, to comply with the standards of safety in making a safe design for the entire system, and to avoid situations in which a malfunction or failure of such TOSHIBA products could cause loss of human life, bodily injury or damage to property.
In developing your designs, please ensure that TOSHIBA products are used within specified operating ranges as set forth in the most recent TOSHIBA products specifications. Also, please keep in mind the precautions and conditions set forth in the "Handling Guide for Semiconductor Devices," or "TOSHIBA Semiconductor Reliability Handbook" etc..
- The TOSHIBA products listed in this document are intended for usage in general electronics applications (computer, personal equipment, office equipment, measuring equipment, industrial robotics, domestic appliances, etc.). These TOSHIBA products are neither intended nor warranted for usage in equipment that requires extraordinarily high quality and/or reliability or a malfunction or failure of which may cause loss of human life or bodily injury ("Unintended Usage"). Unintended Usage include atomic energy control instruments, airplane or spaceship instruments, transportation instruments, traffic signal instruments, combustion control instruments, medical instruments, all types of safety devices, etc.. Unintended Usage of TOSHIBA products listed in this document shall be made at the customer's own risk.
- The products described in this document are subject to the foreign exchange and foreign trade laws.
- TOSHIBA products should not be embedded to the downstream products which are prohibited to be produced and sold, under any law and regulations.