

Schottky Diodes

Features

- These diodes feature very low turn-on voltage and fast switching.
- These devices are protected by a PN junction guard ring against excessive voltage, such as electrostatic discharges.
- Space saving LiLiPut package

Mechanical Data

Case: LLP75-3B Plastic Package

Molding Compound Flammability Rating:

UL 94 V-0

Terminals: High temperature soldering guaranteed:
260 °C/10 sec. at terminals

Weight: 5 mg

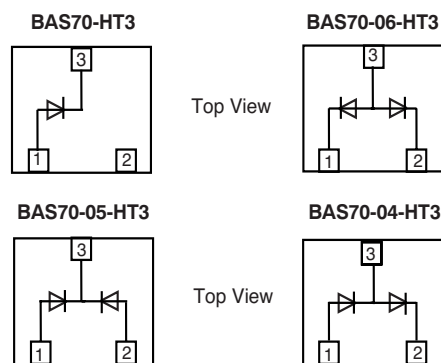
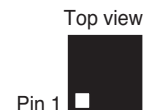
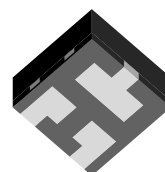

17007

Parts Table

Part	Ordering code	Marking	Remarks
BAS70-HT3	BAS70-HT3-GS08	73	Tape and Reel
BAS70-04-HT3	BAS70-04-HT3-GS08	74	Tape and Reel
BAS70-05-HT3	BAS70-05-HT3-GS08	75	Tape and Reel
BAS70-06-HT3	BAS70-06-HT3-GS08	76	Tape and Reel

Absolute Maximum Ratings

$T_{amb} = 25\text{ °C}$, unless otherwise specified

Parameter	Test condition	Symbol	Value	Unit
Repetitive peak reverse voltage		V_{RRM}	70	V
Forward continuous current	$T_{amb} = 25\text{ °C}$	I_F	200	mA
Surge forward current	$t_p < 1\text{ s}$, $T_{amb} = 25\text{ °C}$	I_{FSM}	600	mA
Power dissipation	$T_{amb} = 25\text{ °C}$	P_{tot}	200	mW

Thermal Characteristics

$T_{amb} = 25\text{ °C}$, unless otherwise specified

Parameter	Test condition	Symbol	Value	Unit
Thermal resistance junction to ambient air		$R_{\theta JA}$	430	°C
Junction temperature		T_j	125	°C
Storage temperature range		T_S	- 55 to +125	°C

BAS70-HT3 to BAS70-06-HT3



Vishay Semiconductors

Electrical Characteristics

T_{amb} = 25 °C, unless otherwise specified

Parameter	Test condition	Symbol	Min	Typ.	Max	Unit
Reverse breakdown voltage	I _R = 10 μA (pulsed)	V _{(BR)R}	70			V
Leakage current	V _R = 50 V, t _p < 300 μs	I _R		20	100	nA
Forward voltage	t _p < 300 μs, I _F = 1.0 mA	V _F			410	mV
	t _p < 300 μs, I _F = 15 mA	V _F			1000	mV
Capacitance	V _R = 0 V, f = 1 MHz	C _{tot}		1.5	2	pF
Reverse recovery time	I _F = 10 mA, I _R = 10 mA, I _{rr} = 1 mA, R _L = 100 Ω	t _{rr}			5	ns

Package Dimensions in mm

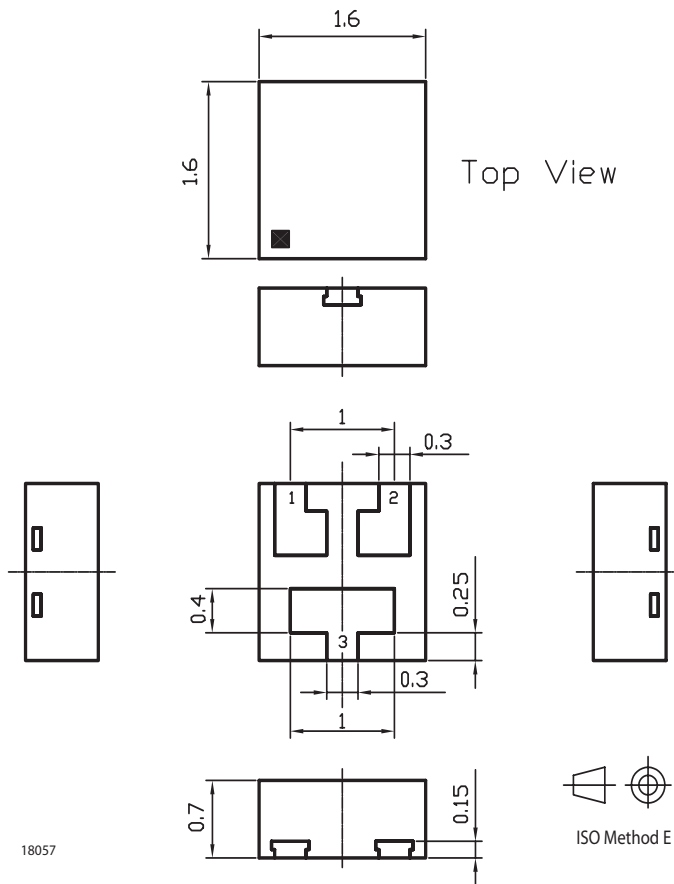



Ozone Depleting Substances Policy Statement

It is the policy of **Vishay Semiconductor GmbH** to

1. Meet all present and future national and international statutory requirements.
2. Regularly and continuously improve the performance of our products, processes, distribution and operating systems with respect to their impact on the health and safety of our employees and the public, as well as their impact on the environment.

It is particular concern to control or eliminate releases of those substances into the atmosphere which are known as ozone depleting substances (ODSs).

The Montreal Protocol (1987) and its London Amendments (1990) intend to severely restrict the use of ODSs and forbid their use within the next ten years. Various national and international initiatives are pressing for an earlier ban on these substances.

Vishay Semiconductor GmbH has been able to use its policy of continuous improvements to eliminate the use of ODSs listed in the following documents.

1. Annex A, B and list of transitional substances of the Montreal Protocol and the London Amendments respectively
2. Class I and II ozone depleting substances in the Clean Air Act Amendments of 1990 by the Environmental Protection Agency (EPA) in the USA
3. Council Decision 88/540/EEC and 91/690/EEC Annex A, B and C (transitional substances) respectively.

Vishay Semiconductor GmbH can certify that our semiconductors are not manufactured with ozone depleting substances and do not contain such substances.

**We reserve the right to make changes to improve technical design
and may do so without further notice.**

Parameters can vary in different applications. All operating parameters must be validated for each customer application by the customer. Should the buyer use Vishay Semiconductors products for any unintended or unauthorized application, the buyer shall indemnify Vishay Semiconductors against all claims, costs, damages, and expenses, arising out of, directly or indirectly, any claim of personal damage, injury or death associated with such unintended or unauthorized use.

Vishay Semiconductor GmbH, P.O.B. 3535, D-74025 Heilbronn, Germany
Telephone: 49 (0)7131 67 2831, Fax number: 49 (0)7131 67 2423