

# WINGET

## OPERATION, MAINTENANCE & SPARE PARTS

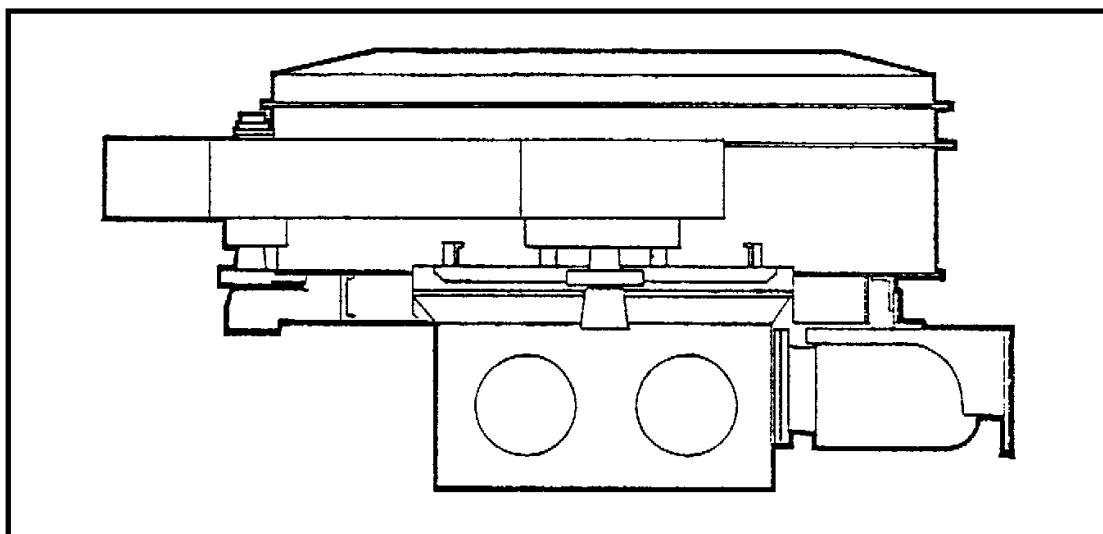

## 1000P2 TURBOMIXER

PRINTED SEPTEMBER 1977 REPRINTED  
APRIL 2003 UPTO M/C No 999

WINGET LIMITED  
PO BOX 41  
EDGEFOLD INDUSTRIAL ESTATE  
PLODDER LANE  
BOLTON  
LANCS  
BL4 OLS

TEL: ++ 44 (0) 1204 854650  
FAX: ++ 44 (0) 1204 854663  
service@winget.co.uk  
parts@winget.co.uk  
www.winget.co.uk

# **WINGET**

# **TURBOMIXER**

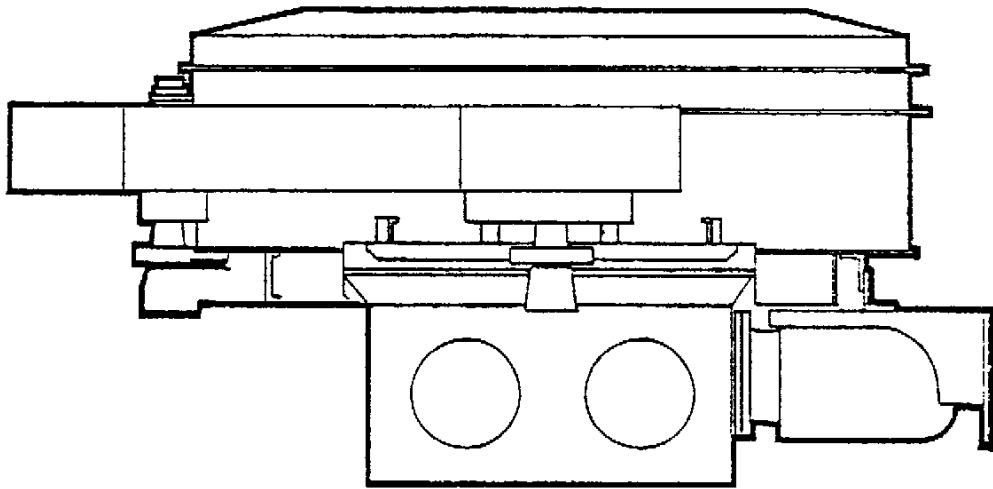

## **1000P2**

This manual is a reprint of the Winget publication No S108 last printed during September 1977, applicable upto M/C S/No 999 and contains some amended part numbers.

Winget Limited operate a policy of continuous product development. Therefore, some illustrations or text within this publication may differ from your machine. The contents of this manual although correct at the time of publication, may be subject to alteration by the manufacturers without notice and Winget Limited can accept no responsibility for any errors or omissions contained within the following pages. Nor can we accept any liability whatsoever arising from the use of this manual howsoever caused.

**II****INTRODUCTION****CONTENTS**

<b>Section</b>	<b>Page</b>	<b>Section</b>	<b>Page</b>
<b>INTRODUCTION</b>		<b>TECHNICAL INFORMATION</b>	
Introduction	III	Specification	5.1
Warranty	IV	Dimensions	5.2
<b>SAFE WORKING</b>		<b>PARTS</b>	6.1
Safe Working	1.1	Spares Groups	6.2
Permit to work systems	1.2		
<b>INSTALLATION</b>			
General	2.1		
Air Operated Discharge Doors	2.1		
Pre-running checks	2.1		
<b>OPERATION</b>			
Mixing	3.1		
Discharging	3.1		
Discharge Door	3.2		
Turbo Mixer Covers			
Trapped Key Interlock System	3.3		
Cleaning the Mixer	3.4		
<b>OVERHAUL &amp; MAINTENANCE INSTRUCTIONS</b>			
Lubrication	4.1		
Gear Box Topping Up	4.1		
Oil Change	4.1		
Air Operated Discharge Door	4.1		
Adjustment of Mixer & Scraper			
Blades	4.2		
Pre-loading of Mixer Arm Springs	4.2		
Fitting New Blades	4.3		
Replacement of Wearing Plates	4.3		
Rotor Gearbox & Motor			
Replacement	4.4		
Discharge Door Cylinder			
Maintenance	4.5		
Service Schedule	4.6		

# INTRODUCTION

# III

## THE HANDBOOK

**WARNING** *The operator must read all the Handbook and fully understand its contents before attempting to operate the machine.*

THE HANDBOOK MUST BE AVAILABLE TO THE OPERATOR AT ALL TIMES.

The Handbook must be kept clean and in good condition. Additional copies of the Handbook can be obtained from Winget Limited.

The contents of this Operator's Handbook are designed as a guide to the machine's controls, operation, working capacities and maintenance. It is **not** a training manual.

Only trained operators should use this machine. Contact the C.I.T.B. or equivalent body for advice on training.

The operating instructions and maintenance recommendations contained in this book will enable you to become familiar with your mixer to obtain the best results in the shortest possible time.

The life and trouble free running of your machine will depend largely on the care it receives. It is your responsibility to ensure that the maintenance instructions outlined in this book are carried out.

When replacements are required, it is essential that only genuine Winget parts are used and that any repair or servicing work is carried out by competent fitters.

In this Handbook are **WARNING** notes. They are preceded by this symbol:



### WARNING



*These notes are used to indicate the procedure being described in the Handbook must be followed to avoid serious injury or death to yourself or to others; or damage to the machine.  
The warnings are also used to protect the machine from unsafe servicing practices.*

Pay particular attention to the warnings given in the Handbook.

If you have any doubts about any aspect of the machine's capability or servicing procedures, you must consult the manufacturer.

## WARRANTY

As every reasonable care is taken that goods of this Company's manufacture shall be free from defect in material and workmanship, the Company will supply free to any destination in the British Isles named in the tender or F.O.B. British Ports in the case of goods situated abroad, any part or parts which, under normal service, appears to the Company's satisfaction to have been at the time of delivery defect in such parts, provided it is notified thereof within twelve months or 2,000 working hours from the date of delivery (whichever shall be the earlier) or, where the Company is responsible for erection, within twelve months from the date on which the customer is notified that any plant or machinery is ready for starting up provided that:-

- a) Written notice is given to the Company within seven days of the discovery of the defect.
- b) Unless otherwise agreed, the alleged defective part or parts are returned to the Company's Works carriage paid and its inspection establishes the claim. Replaced parts shall become the property of the Company.
- c) No part which is not of the Company's manufacture has been fitted, otherwise than by it or on its behalf, or with its written approval.
- d) No unauthorised alteration or modification has been made to the machine or component the subject of the claim.

In no cases shall the Company be responsible for the cost of fitting replacement parts.

Machines parts or components sold by the Company but not of its manufacture are subject only to such warranty (whether expressed or implied by law) as is given by the makers thereof and are not covered by this Guarantee. The Company will as far as is practicable make available to the purchaser the benefit of any warranty given to the Company by the makers of such machines or components.

This Guarantee and/or warranty is personal to the Company's customer and may not be assigned.

Any other warranty or condition expressed or implied by law and whether statutory or otherwise is hereby excluded as is also any claim based on any verbal or other representation or conditions made in relation to any goods the subject of any offer or tender submitted by the Company unless confirmed in writing by a Director of the Company.

Save as aforesaid the Company shall not be responsible for any loss or injury or damage however caused or arising.

# SAFE WORKING

**1.1**

Safety is the responsibility of the persons working with this machine. Think "safety" at all times. *Read and remember the contents of this Handbook.*

## MACHINE MODIFICATION

### WARNING



Any modifications to the machine will affect its working parameters and safety factors. Refer to the Manufacturers before fitting any non-standard equipment or parts.

The manufacturers accept no responsibility for any modifications made after the machine has left the factory, unless previously agreed by the Manufacturers in writing. The Manufacturers will accept no liability for damage to property, personnel or the machine if failure is brought about due to such modifications, or fitment of spurious parts.

### IMPORTANT

Your TURBOMIXER is a high speed Mixer.

The mix should never be allowed to remain in the Pan for a period in excess of twice the mixing time required for any particular mix, otherwise, heavy overloading of the gearbox will result.

Average mixing times are given on Page 3.1 of this book.

Recourse to a wet Hopper should be arranged if the take-off from the plant is erratic.

### WARNING



Under no circumstances should the Mixer be stopped and re-started during the mixing cycle.

Purchasers are advised to familiarise themselves with the requirements of Paras. 38 to 42 of the "Advisory Code on Safety in Batching Plants" when fitting mixers to plants.

NOTE: When a mixer is supplied as a part of a Batching Plant, the safety arrangements will probably differ from those indicated in this Manual. Check that you understand the safety arrangements of the Manual provided with the Batching Plant before carrying out any maintenance.

**1.2****SAFE WORKING****PERMIT TO WORK SYSTEMS - PARAGRAPH 53 (BS/5304)****53.1      Circumstances of Use**

Interlocking guards (see clause II) and safety devices provided at small units of machinery for the protection of the Operator also protects the maintenance man when he requires access to the danger area. At larger machinery and process plant however, this protection may not be available to Maintenance Personnel who, having entered a danger area, may be out of sight and therefore exposed to danger if the plant is switched on.

In these circumstances it is necessary for management to identify the hazards which are exposed and to develop a safe system of work whereby these hazards are eliminated or as a last resort, recognised by the employee(s) so that personal precautions against possible injury can be taken. Oral instructions, requests or promises are liable to be misheard, misinterpreted or forgotten and are therefore, not a satisfactory basis for action of which men's lives may depend. The unsatisfactory working of such procedures has been proved time and again.

**53.2      A written System**

Effective control should be achieved by means of a written system, though even this relies on the human element, for no documentary system can by itself prevent accidents. The system, which is known as a permit to work system, requires formal action on the part of those doing the work, those responsible for it and those authorised to sign such permits.

**53.3      Contents**

- a) Such a permit should clearly set for management, employees and other persons, for example, outside contractors
- b) The work to be done.
- c) Who will supervise the work.
- d) Who is to carry out each section of the work.
- e) The safety precautions which have been taken.
- f) The precautions which still need to be taken by the employee before commencing work, for example, affixing physical locking devices and danger boards.
- g) A time limit (if necessary) within which a check needs to be carried out to see if the working environment is still safe.
- h) The procedure that should be followed before the permit to work is cancelled.

# 1.3 SAFE WORKING

The person responsible for undertaking the work should sign a statement signifying that he understands the task and the precautions to be taken.

## 53.4 Advantages

A safe procedure is therefore specified forming a clear record of all the foreseeable hazards which have been considered in advance, together with the appropriate precautions taken in their correct sequence. Adequate supervision to see that the system operates properly is required.

Work in potentially hazardous circumstances can be done in safety by the use of this method and the confidence of employees can be gained. The design of a permit to work will depend on the nature and degree of risk, the complexity of the task and the industry to which it relates.

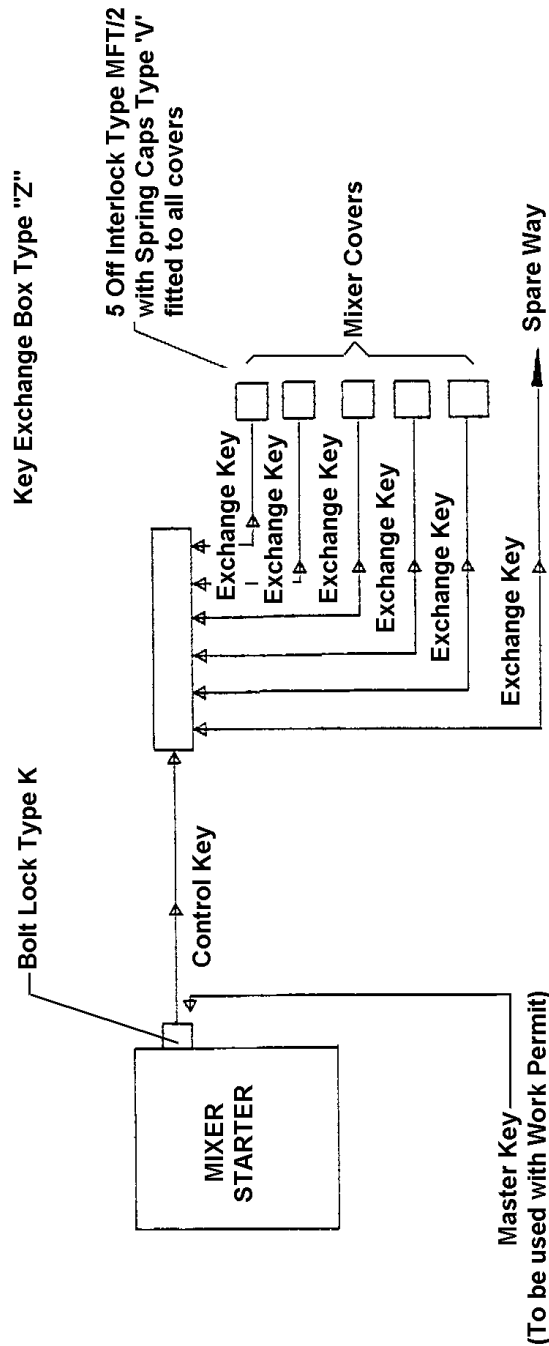



**2.1****INSTALLATION****INSTALLATION**

## General

The Mixer must be installed in its working position ensuring that it is mounted horizontally, and that there is no distortion of the base frame. Provision should be made below the Mixer to allow a free circulation of cooling air in and around the electric drive motor.



Access to the discharge door(s) from the underside of the Mixer is recommended for inspection and maintenance of the mixing blades, subject to the recommendation of Paras. 38 to 42 of the Advisory Code on Safety in Batching Plants.

Air Operated Discharge Door(s)

The standard discharge door is operated by an air cylinder. The working pressure required is in the range of 5.52 to 6.9 Bar (80 to 100 p.s.i.) but should not exceed 10.3 Bar (150 p.s.i.). The air supply is first passed through a filter to remove any dirt or moisture present, and then through an atomizing type airline lubricator.

If doors are hand, hydraulic or electrically operated, separate information is provided.

PRE-RUNNING CHECKS

Check the level of oil in Gearbox, top up as necessary. See pages 4.1 and 4.4 for instructions.

Check 1.6mm (1/16") clearance between blades and pan, adjust as necessary. See Page 4.2.

If the Mixer is being used for the first time after the electrical circuit has been connected or re-connected, ensure correct rotation of mixing blades.

If the water system has been drained, re-connect supply and pass a quantity of water through flowmeter to ensure accurate operation.

Check that safety arrangements are fitted, that you understand the method of operation and that they are in working order.

**3.1****OPERATION**OPERATIONMixing

It is important that the mixing blades are rotating at their full working speed before any material is fed into the pan.

It is recommended that to reduce the mixing time cycle to a minimum where possible, the cement, water and aggregate be added to the pan simultaneously.

Mixing time will vary depending on the type of mix, but should NEVER be less than thirty seconds, the average time being thirty to forty-five seconds.



NOTE: The mix should never be allowed to remain in the pan after mixing time has expired.

The action of the mixing blades and aggregate generates a small amount of heat, which will cause the water content to drop and consequently stiffen the mix. This stiffening would eventually reach a point when it would cause the over-load trip mechanism of the starter switch to operate and stall the Mixer.

In the event of the Mixer stalling, the discharge door(s) should be opened, water added to the mix and as much concrete as possible shovelled out before any attempt is made to restart the electric motor.

With the trapped key interlock system supplied with the mixer used, as instructed, it is impossible for the mixer to be started while the above operation is in progress. This will also apply when the mixer is supplied as an integral part of a batching plant fitted with a trapped key interlock system.



WHERE THE PURCHASER HAS AGREED TO PROVIDE SAFETY ARRANGEMENTS, IT IS ESSENTIAL THAT THEY DO NOT ALLOW THE MIXER TO BE STARTED WHILE THE CLEARING OPERATION IS IN PROGRESS.

Discharging

An air operated semi-circular shaped discharge door(s) in the bottom of the mixing pan, allows the concrete to be quickly discharged by the action of the rotating mixing blades.

## 3.2

## OPERATION



It is recommended that on a Mixer fitted with two or more discharge Doors, that if only one is consistently used for any period, to prevent the unused door(s) from sticking, that it/they be opened after approximately every ten batches, to remove any grout that will have accumulated in the crevice between the door and the pan.

### Cleaning the Mixer

See Page 3.4

**3.3****OPERATION****TURBO MIXER COVERS**

Grouping No \_\_\_\_\_

Trapped Key Interlock System

The standard Mixer is supplied complete with covers and starter, protected by a trapped key interlock system, see page 1.3. Mixers may also be supplied:-

- a) Less Starter
- b) With Starter but less trapped key interlock on Starter
- c) Less Covers
- d) With Covers but less trapped key interlocks
- e) Combination of items a - d

Winget Limited will not accept responsibility for the safe working of a Mixer supplied as items a - e. Mixers are in fact supplied as items a - e but only on a written undertaking by the purchaser to take specified steps sufficient to ensure that the machine is safe and without risks to health when properly used.

Mixer sizes 333P2 to 750P2 - These are protected by interlocks as indicated on flow diagram 506740500. This comprises a bolt lock type K, with control key fitted to the starter, a key exchange box with four keys, three locks type MFT2 fitted to the three openings in the mixer covers, and a master key recognised by the 'T' shaped handle.

In the normal working condition, the control key is in the operated position in the starter, and the isolator turned to the 'ON' position. The mixer covers are in the closed position with the locks secured and four keys are in the exchange box. In this condition all keys are trapped and cannot be removed from the bolt lock 'K'. If the key is inserted in the key exchange box and turned, the four keys are freed, and may be removed, but the control key is trapped in the box, making it impossible to start the mixer while the four keys are not in position in the exchange box.

Three of the keys are used for operating the locks type MFT2 fitted to the Mixer openings. When operated to release the locks, the keys are trapped in the locks. A locating arrangement is fitted to the removable top cover to ensure that the lock cannot be operated with cover detached.

The fourth key is not required for opening the mixer covers, but is supplied so that a further chain of interlocks may be initiated if so required.

Each set of keys is specific to the mixer for which it is supplied. Any queries or spares requirement should be accompanied by the Grouping Number indicated under the title of this section of the Manual.



The master key **MUST** be kept in the possession of a person in authority. It is provided to enable the mixer to be run with the covers open, to check adjustments. **IT IS TO BE ISSUED BY THE PERSON IN AUTHORITY, ONLY WITH A 'PERMIT TO WORK SYSTEM'**. The requirements of a 'Permit to Work System' are indicated under the "Safe Working" section. See page 1.2

**3.4****OPERATION**

When the mixer is supplied with a plant, a different interlock system may be fitted and it is **IMPERATIVE** to be familiar with the arrangements fitted, which will be described in the plant manual.

Mixer Sizes 1000P2 to 2000P2 - These are protected by an interlock system as indicated on the Flow Diagram (506740600). The system works in exactly the same way as that for the smaller mixers, with the exception that there are five openings in the mixer covers, instead of three, and the key exchange box is fitted with six trapped keys.

CLEANING THE MIXER

Remember, a clean mixer is more efficient, reducing considerably the wear on the pan and mixing elements.

At the end of each day's work, or if the mixer is idle for a period of more than one hour, the mixer should be thoroughly washed to prevent concrete setting in the pan or on the mixing elements.

Initial cleaning can be carried out by introducing a quantity of gravel and water and running the mixer for three to four minutes. This will not clean the mixer completely.

Utilizing the trapped key interlock system, open the covers and hose down with a high pressure hose. Close the covers and, using the trapped key arrangements, restart the mixer, run for a few minutes and discharge. A gradual build-up of set concrete may occur after extended use, and a man may have to enter the mixer pan to chip off the build-up.

Using the trapped key system, as described, backed up by a 'Permit to Work' arrangement, the man will be safe, but **ENSURE THAT THE MASTER KEY IS WITH THE PERSON IN AUTHORITY**. If the mixer is supplied as part of a plant, a different interlock system may be fitted - **ENSURE THAT THIS IS UNDERSTOOD BEFORE ALLOWING A MAN TO ENTER THE MIXER**.



These instructions apply only to safety arrangements supplied by Winget. Where customers have contracted to supply their own safety arrangements, **THE PERSON IN AUTHORITY MUST CHECK THE SAFETY ARRANGEMENTS ACTUALLY FITTED BEFORE ANY WORK IS CARRIED OUT ON THE MIXER**.

Coating the interior of the mixer with mould oil will reduce concrete build-up.

ADJUSTING BLADES AND MAINTENANCE

This must be carried out using the trapped key system together with a 'Permit to Work' system. In checking blade clearances it is necessary to rotate the rotor slowly. Due to the drive arrangements this can be achieved only by a momentary operation of the starter. Since the covers will be open, and the master key is required to override the trapped key system **THIS IS A DANGEROUS OPERATION**. IT IS THE CUSTOMER'S RESPONSIBILITY TO ENSURE THAT THE DANGERS ARE HIGHLIGHTED IN THE 'PERMIT TO WORK' DOCUMENT.



## 4.1 OVERHAUL & MAINTENANCE INSTRUCTIONS



WARNING: BEFORE ANY MAINTENANCE WORK IS CARRIED OUT, ENSURE THAT THE TRAPPED KEY INTERLOCK IS FULLY UNDERSTOOD, AND WHETHER IT APPLIES TO THE MIXER ONLY, OR THE COMPLETE PLANT IF MIXER IS SUPPLIED IN A PLANT. ENSURE THAT A 'PERMIT TO WORK' SYSTEM IS PROVIDED AND UNDERSTOOD.

IF THE MIXER HAS BEEN SUPPLIED AS ITEMS A TO E (PAGE 3.3) IT IS THE CUSTOMER'S RESPONSIBILITY TO ENSURE THAT SUITABLE SAFETY ARRANGEMENTS ARE PROVIDED.

### LUBRICATION

#### GEARBOX - Topping Up

The oil level should be checked at weekly intervals with the oil COLD using the sight glass fitted in the oil reservoir mounted on the side of the pan. If necessary, top up with recommended oils to the level of the centre of the sight glass.

#### Oil Change

Oil in the Gearbox should be changed after every 1000 hours running. This is best carried out at the end of a day's working with the machine stationary when the oil is warm, but allowing enough time for the oil to settle.

1. Remove drain plug from the bottom of the gear case and collect the oil in a suitable container. Capacity 23 litres 40 pints. Dispose of waste oil in accordance with local regulations.
2. Refill with recommended oils to the level of the sight glass.

Recommended oils are as follows:-

TOTAL - EP80W/90 or equivalent for temperatures up to 32° C - 90° F Ambient

TOTAL - EP85/140 or equivalent for temperatures over 32° C - 90° F Ambient

#### Air Operated Discharge Door

Two grease nipples provided requiring lubrication at weekly intervals. Oil level in air line lubricator should be checked daily.

Recommended oils are as follows:-

TOTAL	Azzola ZS22
SHELL	Tellus 21
ESSO	Norpol 35
CALTEX	Caltex Spinde Oil A
MOBIL	Mobil Velocite No. 6

NOTE: See Page 4.6 for Lubrication and Servicing Schedule

## 4.2 OVERHAUL & MAINTENANCE INSTRUCTIONS

### ADJUSTMENT OF MIXING AND SCRAPER BLADES

The blades should be inspected daily for wear and adjusted if necessary to give approximately 1.6mm (1/6") clearance between the blades and the tightest spot on the circumference of the pan and the pan bottom.

This should be carried out by slackening the blade bolts and repositioning the blades on the slotted holes provided. Access to the mixing blade bolts is best achieved by positioning the blade over the door opening.

After any adjustments have been made, it is recommended that the rotor be rotated slowly to ensure all-round clearance of the blades to allow for any possible distortion of the pan.

NOTE: It is not possible to rotate the rotor by hand and it will be necessary to momentarily operate the mixer starter to give partial rotation of the rotor.

Alternatively remove the motor fan cowl and turn the fan by hand.

### Pre-loading of Mixing Arm Springs

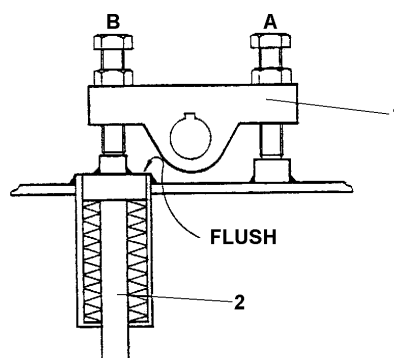

1. Remove the cover plate from the top of the rotor.
2. Slacken blade bolts and raise the blade on the slotted holes as far as possible.
3. Slacken locknuts on Screws A and B.
4. Adjust Screw A so that the top of the rocker (Ref. 1) is horizontal.
5. Adjust Screw B so that the top of the collar on the shock absorber pin (Ref. 2) is flush with the top of the tube welded into the rotor base plate.
6. Tighten both locknuts and replace rotor cover plate.
7. Re-adjust blade to 1.6mm (1/16") clear of the pan bottom and side.

NOTE: These screws should not be used for blade height adjustment.

## **4.3 OVERHAUL & MAINTENANCE INSTRUCTIONS**

### FITTING NEW BLADES

Badly worn blades should be removed as follows:-

Open the discharge door and position the worn blade over the door opening. (See note regarding rotation of rotor).

Detach the blade by removing the two fixing bolts securing it to the blade arm.

Fit new blade and set to correct clearance from pan bottom. Rotate rotor slowly as previously described to check clearance all round pan.

### REPLACEMENT OF WEARING PLATES

To assist in the replacement of wearing plates, they have been divided into easily removable sections. After any plates have been replaced, it is recommended that the rotor be turned slowly to ensure correct adjustment of blades. (See Note).



**IMPORTANT NOTE: REMOVAL OF THE PAN COVER CANCELS THE SAFETY ARRANGEMENTS. ENSURE THAT THE FOLLOWING WORK IS CARRIED OUT USING A 'PERMIT TO WORK'. ENSURE ALSO THAT THE ISOLATOR IS SWITCHED OFF, THAT THE TRAPPED KEY THUS FREED IS RETAINED ON HIS PERSON BY THE MAN CARRYING OUT THE REPLACEMENTS, AND THAT THE FUSES ARE REMOVED. CHECK THAT THE OVERRIDE KEY IS IN THE POSSESSION OF THE RESPONSIBLE PERSON ISSUING THE PERMIT TO WORK.**

THE ABOVE APPLIES TO THE STANDARD SAFETY ARRANGEMENTS PROVIDED. CHECK SAFETY ARRANGEMENTS IF MIXER IS SUPPLIED AS PART OF PLANT, OR IF SAFETY ARRANGEMENTS WERE NOT SUPPLIED BY WINGET.

### Bottom and Inner Plates

1. Remove pan cover to expose mixing blades.
2. Detach one mixing arm by removing the two bolts, which secure it to its pivot shaft.
3. Rotate rotor so that the remaining arms and blades are clear of the wearing plate segment to be removed.
4. Remove the countersunk screws and lift the wearing plate from the pan.
5. Fit new wearing plate, assembly mixing arm and top cover.



## **4.4 OVERHAUL & MAINTENANCE INSTRUCTIONS**

### Outer Wearing Plate

1. Remove pan cover to expose mixing blades.
2. Rotate rotor until outer blade arms are clear of segment to be replaced.
3. Remove the countersunk fixing bolts and lift wearing plate from pan.
4. Fit new wearing plate, assembly mixing arm and top cover.

### ROTOR, GEARBOX AND MOTOR REPLACEMENT

The notes given in this section are intended for general guidance only.

1. Disconnect the electrical supply from the mixer by removing the fuses and the electrical connections at the motor. These should be clearly labelled to assist in easy reconnection.
2. Drain the oil from the Gearbox into a suitable clean container and detach the filling tube and bracket. Dispose of waste oil in accordance with local regulations.
3. Remove pan cover and rotor cover plate to obtain access to the eight bolts securing the rotor and lift off rotor complete with arms if headroom available or detach blade arms if not.
4. Screw M20 lifting eye into centre of gearbox shaft.
5. Attach suitable lifting tackle and take weight of the box.
6. Remove the four bolts securing the prop shaft to the gearbox input flange.
7. Remove the nine bolts and three nuts securing the gearbox to the pan bottom and lower the assembly from the pan.
8. If necessary the motor may be removed separately by removing the four bolts in the motor feet and the four bolts in the prop shaft flange.

To refit the gearbox and motor carry out reverse procedure to above, finally refilling the gearbox with oil to correct level. See Page 4.1 for recommended oil and capacity.

Remake electrical connections and check direction of rotor rotation.

Check blade clearances as on Page 4.2.

Replace pan covers before using the mixer.

## **4.5 OVERHAUL & MAINTENANCE INSTRUCTIONS**

### AIR OPERATED DISCHARGE DOOR

#### Cylinder Maintenance

The air cylinders have been developed to give trouble free maximum cycle performance with minimum maintenance. It is however, essential to exclude moisture, pipe scale and other foreign matter and to ensure that a constant line pressure with effective lubrication is available at the point of application. This can be provided by fitting an air line filter and lubricator in the main air line with the lubricator positioned between the filter and the valve controlling the cylinder.

Under reasonable conditions the seals will last for a long time but when it eventually becomes necessary to replace them it is advisable to use a seal fitting tool for the piston rod seals.

The cylinder end caps should be removed at regular intervals and the piston rod assembly withdrawn, cleaned and inspected. The cylinder, piston rod and seals should be cleaned by washing in white spirit or paraffin. In no circumstances should any form of degreasing fluid be used.

It is advisable to hold the cylinder in a vice so that both hands are free to guide the piston packing passed the leading edge into the cylinder bore. The seals are a major contributing factor to the efficient operation of the cylinder and, therefore, every care should be taken to ensure that they are not damaged during assembly.

## 4.6 OVERHAUL & MAINTENANCE INSTRUCTIONS

### LUBRICATING AND SERVICING SCHEDULE

DAILY or 24 Working Hours	
GENERAL	Thoroughly clean the inside and outside of the Mixer paying particular attention to mixing and scraper blades. Give Mixer a coating of equal parts of paraffin and engine oil. Apply a little engine oil to all moving parts, pin joints on discharge doors etc.
DISCHARGE DOOR	* Use Grease Gun - 2 Nipples
AIRLINE LUBRICATOR	Check Oil Level, See Page 4.1 for recommended Oils.
WEEKLY or 200 Working Hours	
GEARBOX	Check oil level using sight glass, top up if necessary. Top up with recommended oil only, See Page 4.1. * Use Grease Gun - 2 Nipples
MONTHLY or 800 Working Hours	
ROTOR ARMS	* Use Grease Gun - 9 Nipples
SIX WEEKLY or 1000 Working Hours	
GEARBOX	Change Oil in Gearbox, See Page 4.1

\*TOTAL MULTIS 2 or SHELL "ALVANIA" Grease No. 2 or "UNEDO" Grease No. 2

**5.1****TECHNICAL INFORMATION**SPECIFICATION

## BATCH FEEDING BASED ON 50 BATCHES PER HOUR

BATCH	Input Output	1500 Litres/54 Cu. Ft 1000 Litres/36 Cu. Ft.
OUTPUT	Cu. M./Hr. Cu. Yds./Hr.	50 66
MOTOR	h.p. r.p.m.	60 1470
WEIGHT	Kilos lbs.	4226 9316.6
NO. OF MIXING BLADES		9

## OVERALL DIMENSIONS

Length	Mm	Ins
		107.9
D1	2742	
D2	1350	53.1
H1	1342	52.8
H2	367	14.4
H3	470	18.5
H4	163	6.4
H5	709	27.9
H6	203	8.0
L1	1594	62.7
L2	2910	114.6
L3	2159	85.0
L4	1610	63.4
L5	680	26.8
L6	1302	51.2
R1	1710	67.4
R2	704	27.7
R3	440	17.3
R4	1960	77.2

WINGET LTD RETAIN THE RIGHT TO ALTER THIS SPECIFICATION WITHOUT NOTICE IN ACCORDANCE WITH THEIR POLICY OF CONTINUOUS PRODUCT IMPROVEMENT.

5.2

TECHNICAL INFORMATION

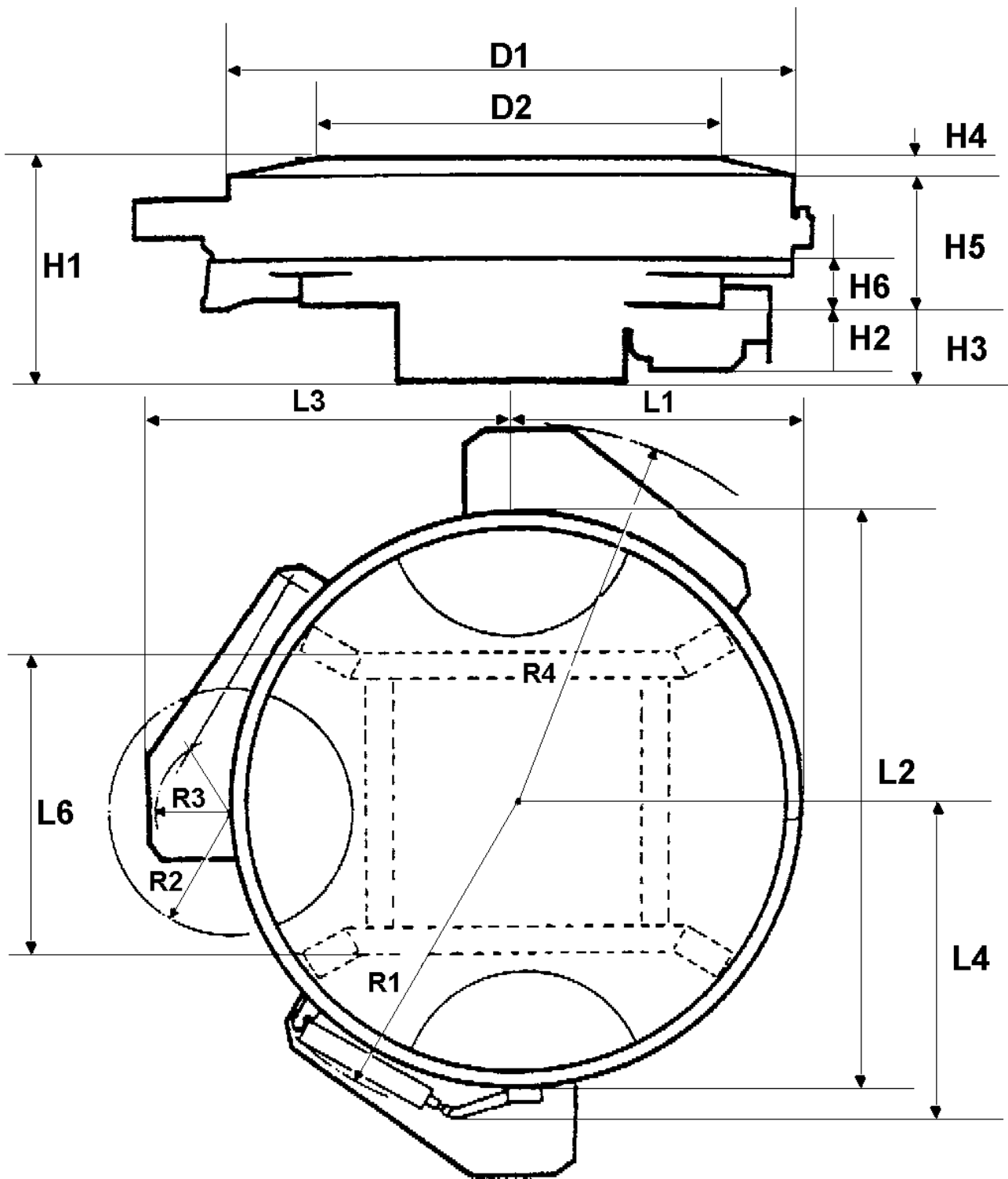

## 6.1

## SPARE PARTS

### TO FIND A SPARE PART

The assemblies have been divided into groups and given identification letters A, B, C etc. To identify a component, first find the relevant assembly in the list given on Page 6.2, this will give you a group letter to turn to. On turning to this group the illustrations will enable you to identify the part you required and give you a reference number. Against this number in the Parts List will be found the DESCRIPTION AND PART NUMBER information, which we require.

To avoid delays and errors, remember always to quote THE MACHINE NUMBER, which will be found stamped on a plate at the side of the machine.

**6.2****SPARE PARTS**SPARES GROUPS

A1	Subframe and Mounting Pedestal Assembly
A2	Mixing Pan and Wear Plates Assembly
A3	Pan Bottom Wear Plates Assembly
A4	Pan Covers Assembly
B1	Rotor and Blades Assembly
B2	Rotor Transmission Assembly
B3	Gearbox Assembly
C1	Discharge Door Assembly
C2	Door Limit Switch Assembly
C3	Door Cylinder Guard Assembly

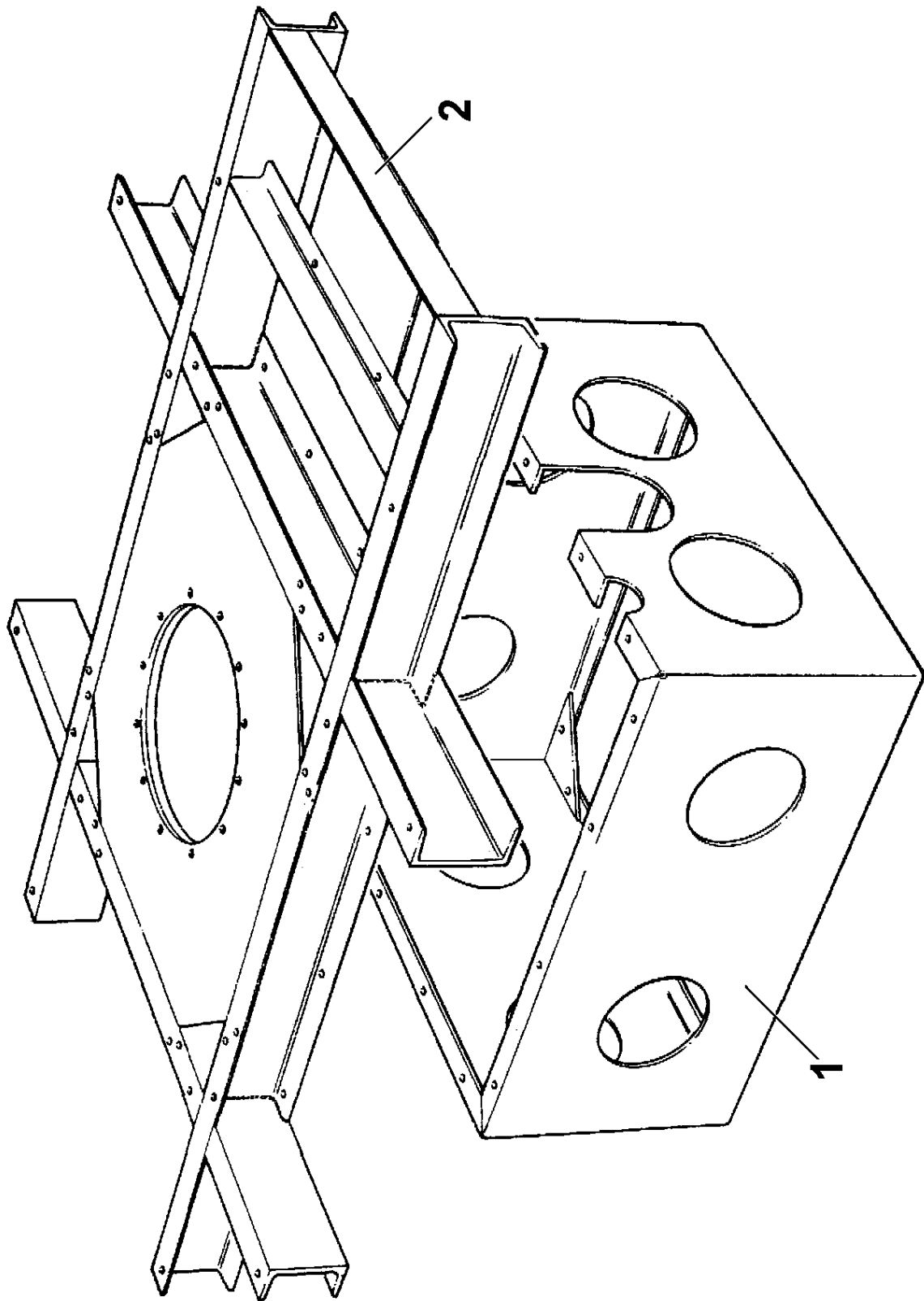



**SUBFRAME & MOUNTING PEDESTAL ASSEMBLY****A - 1**

<b>Item</b>	<b>Part no</b>	<b>Serial no</b>	<b>Description</b>	<b>Qty</b>
1	514420400		Mounting Pedestal	1
1A	11S05E		Screw Set	16
1B	17S06		Washer Spring	16
1C	105S05		Washer Tapered	16
1D	7S05		Nut	16
2	514421100		Sub Frame	1
2A	52S05G		Screw C'sunk Slit	16
2B	17S06		Washer Spring	16
2C	105S05		Washer Tapered	16
2D	7S05		Nut	16

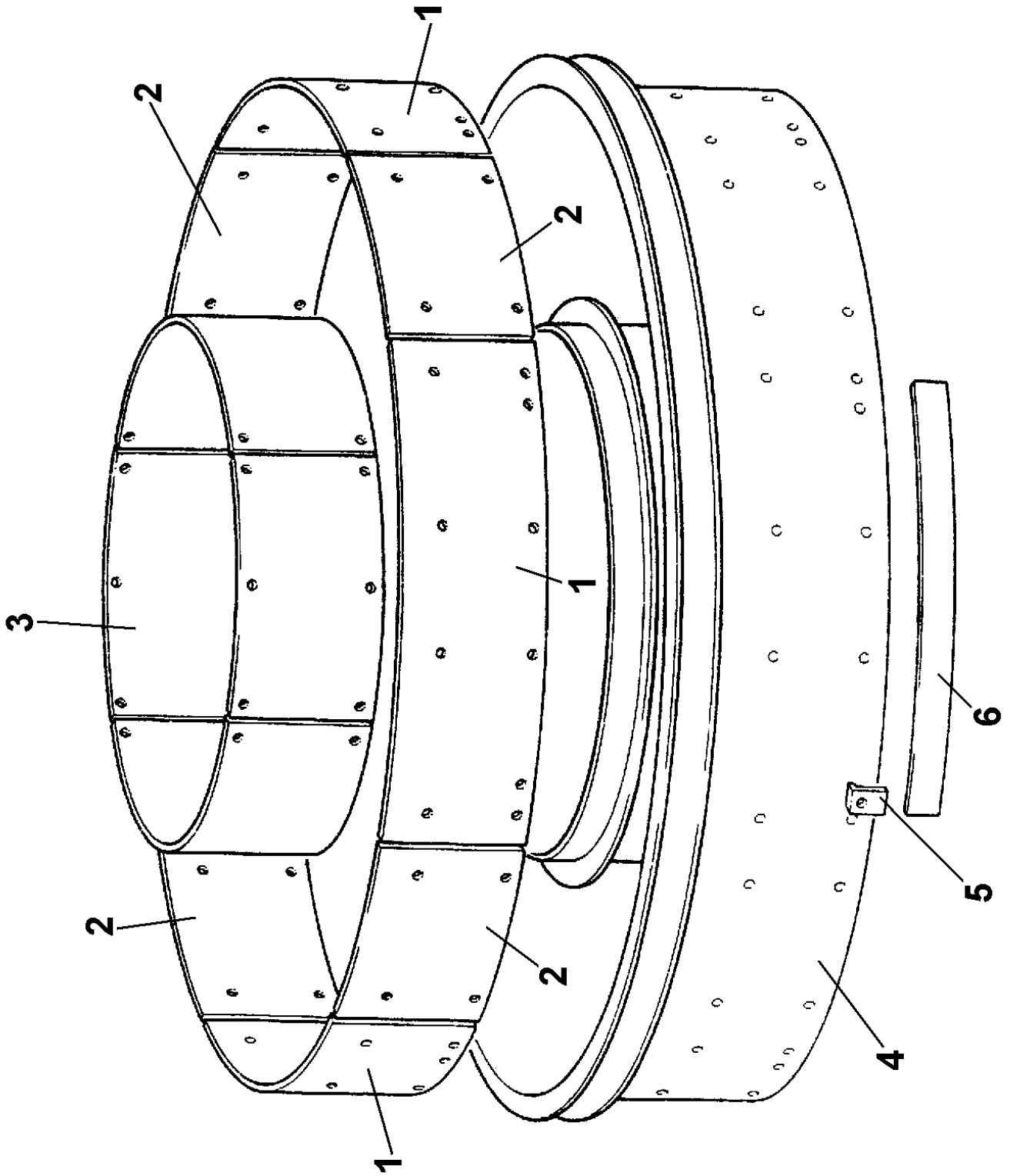

**MIXING PAN & RIM WEAR PLATES ASSEMBLY****A - 2**

Item	Part no	Serial no	Description	Qty
<b>PAN WITH 1 DOOR</b>				
1	514421900		Outer Wearing Plates (long)	4
1A	52S05G		Screw C'sunk Slit	36
1B	52S05K		Screw C'sunk Slit	4
1C	17S06		Washer Spring	40
1D	7S05		Nut	40
2	514422000		Outer Wearing Plates (short)	4
2A	52S05G		Screw C'sunk Slit	24
2B	17S06		Washer Spring	24
2C	7S05		Nut	24
3	514418200		Inner Wearing Plate	4
3A	52S05G		Screw C'sunk Slit	24
3B	17S06		Washer Spring	24
3C	7S05		Nut	24
4	514420600		Mixing Pan	1
5	514423400		Sealing Strip Clamp	4
6	514423700		Door Sealing Strip	1
<b>PAN WITH 2 DOORS</b>				
1	514421900		Outer Wearing Plates (long)	4
1A	52S05G		Screw C'sunk Slit	32
1B	52S05K		Screw C'sunk Slit	8
1C	17S06		Washer Spring	40
1D	7S05		Nut	40
2	514422000		Outer Wearing Plates (short)	4
2A	52S05G		Screw C'sunk Slit	16
2B	17S06		Washer Spring	16
2C	7S05		Nut	16
3	514418200		Inner Wearing Plate	4
3A	52S05G		Screw C'sunk Slit	24
3B	17S06		Washer Spring	24
3C	7S05		Nut	24
4	514420600		Mixing Pan	1
5	514423400		Sealing Strip Clamp	8
6	514423700		Door Sealing Strip	2
<b>PAN WITH 3 DOORS</b>				
1	514421900		Outer Wearing Plates (long)	4
1A	52S05G		Screw C'sunk Slit	28
1B	52S05K		Screw C'sunk Slit	12
1C	17S06		Washer Spring	40

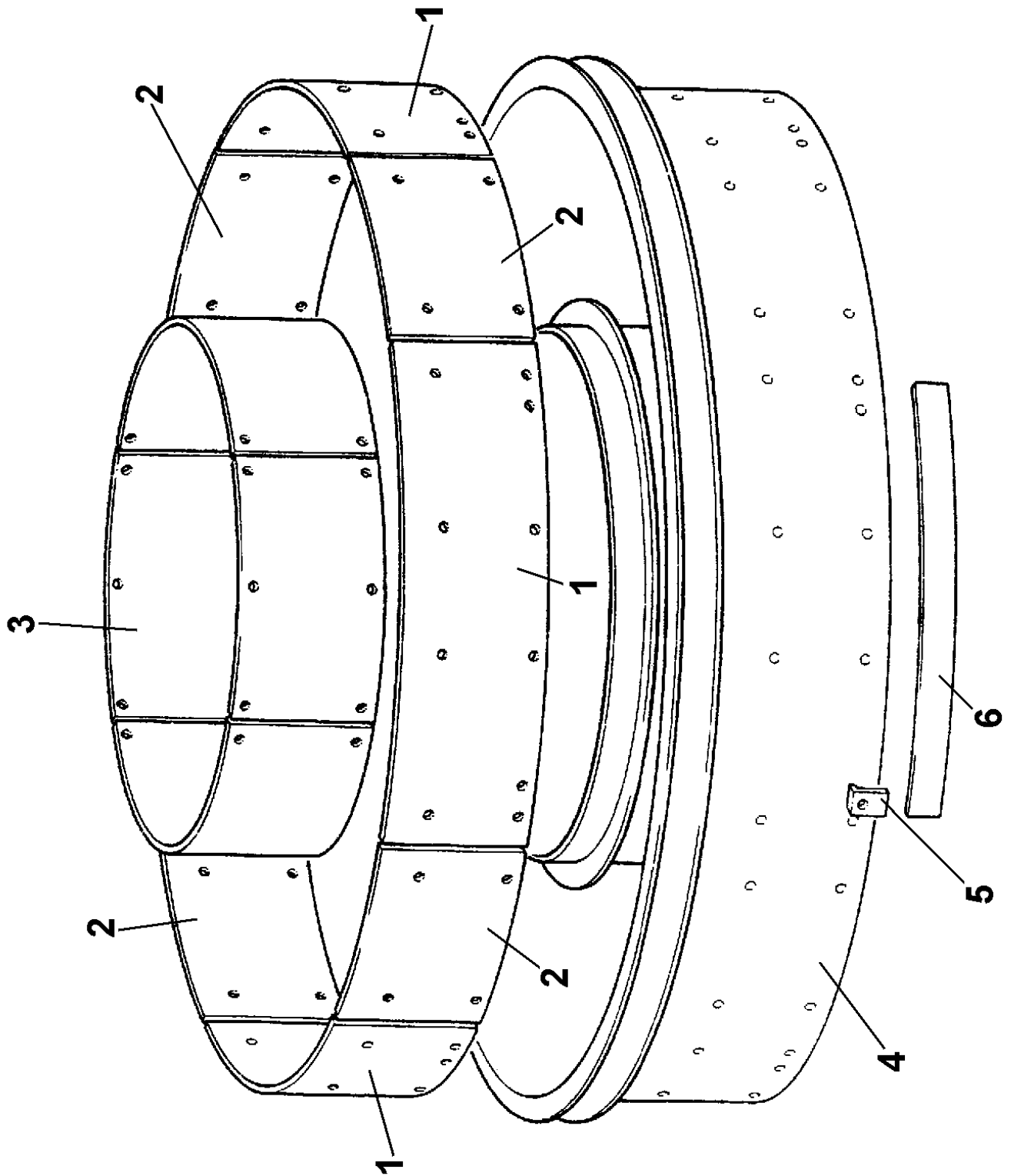

**MIXING PAN & RIM WEAR PLATES ASSEMBLY****A - 2**

Item	Part no	Serial no	Description	Qty
<b>PAN WITH 3 DOORS, CONTINUED</b>				
1D	7S05		Nut	40
2	514422000		Outer Wearing Plates (short)	4
2A	52S05G		Screw C'sunk Slit	16
2B	17S06		Washer Spring	16
2C	7S05		Nut	16
3	514418200		Inner Wearing Plate	4
3A	52S05G		Screw C'sunk Slit	24
3B	17S06		Washer Spring	24
3C	7S05		Nut	24
4	514420600		Mixing Pan	1
5	514423400		Sealing Strip Clamp	12
6	514423700		Door Sealing Strip	3

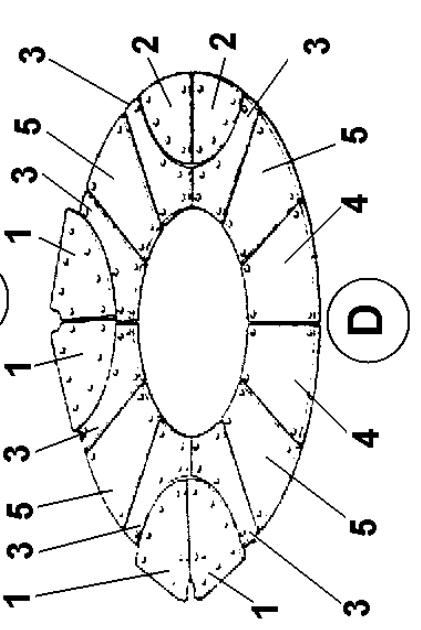
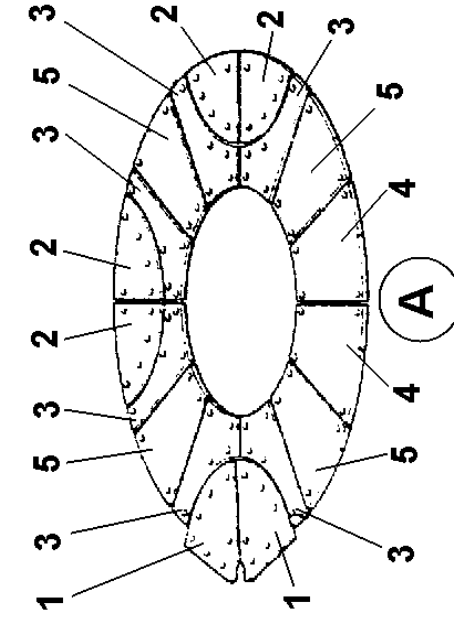
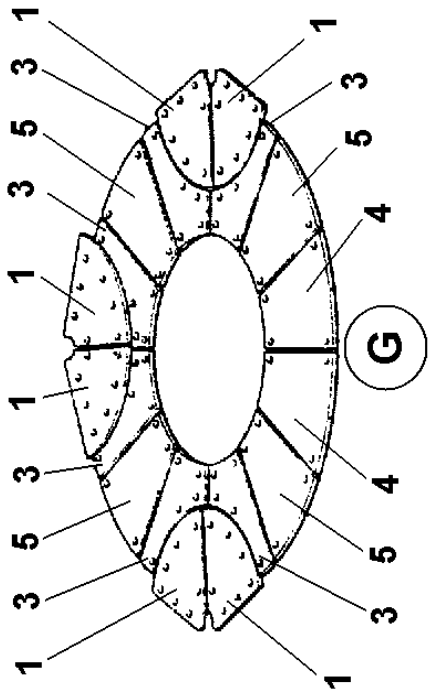
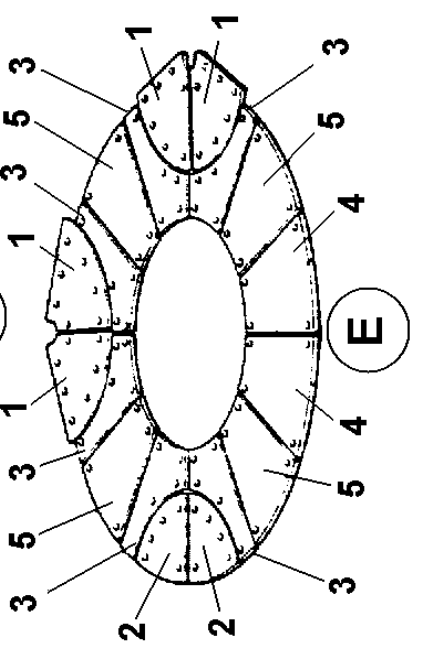
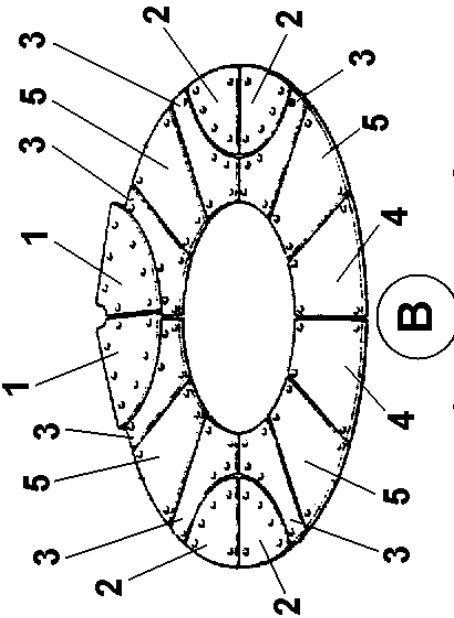
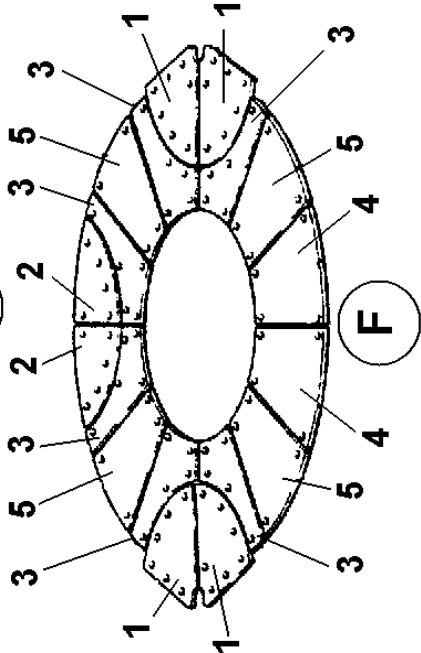
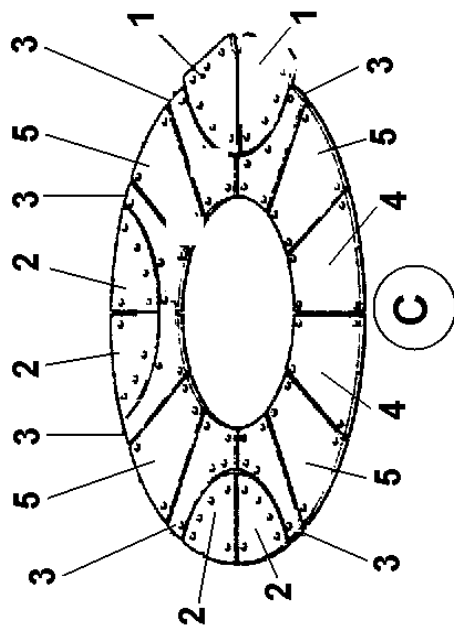

**PAN BASE WEAR PLATES ASSEMBLY****A - 3**

Item	Part no	Serial no	Description	Qty
<b>PAN WITH 1 DOOR-REFS A, B &amp; C</b>				
1	514421300		Door Wearing Plate LH	1
1A	514421300		Door Wearing Plate RH	1
1B	52S05K		Screw C'sunk	14
1C	17S06		Washer Spring	14
1D	7S05		Nut	14
2	514421400		Modification to Door Wear Plate LH	2
2A	514421400		Modification to Door Wear Plate RH	2
2B	52S05G		Screw C'sunk	20
2C	17S06		Washer Spring	20
2D	7S05		Nut	20
3	514421500		Bottom Wear Plate-Door Opening LH	3
3A	514421500		Bottom Wear Plate-Door Opening RH	3
3B	52S05G		Screw C'sunk	12
3C	17S06		Washer Spring	12
3D	7S05		Nut	12
3E	52S05J		Screw C'sunk	12
3F	105S05		Washer Tapered	6
3G	17S06		Washer Spring	12
3H	7S05		Nut	12
3J	52S05L		Screw C'sunk	6
3K	17S06		Washer Spring	6
3L	7S05		Nut	6
4	514421600		Bottom Wearing Plate 33'	2
4A	52S05G		Screw C'sunk	4
4B	17S06		Washer Spring	4
4C	7S05		Nut	4
4D	52S05J		Screw C'sunk	4
4E	105S05		Washer Tapered	2
4F	17S06		Washer Spring	4
4G	7S05		Nut	4
5	514421700		Bottom Wearing Plate 24'	4
5A	52S05G		Screw C'sunk	8
5B	17S06		Washer Spring	8
5C	7S05		Nut	8
5D	52S05J		Screw C'sunk	8
5E	17S06		Washer Spring	8
5F	7S05		Nut	8

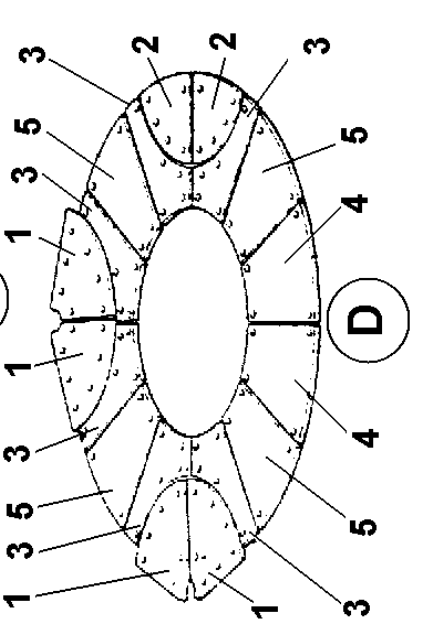
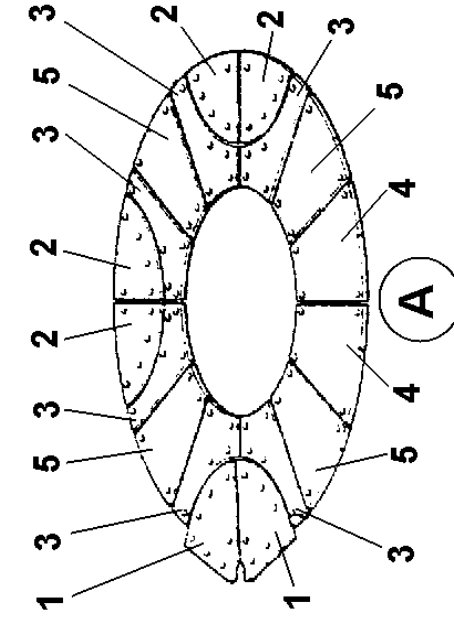
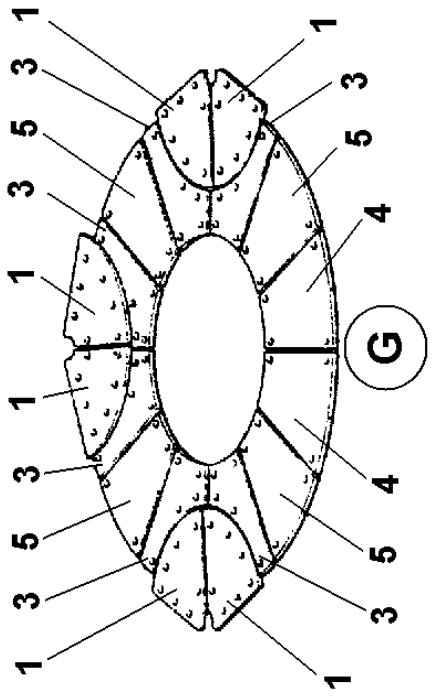
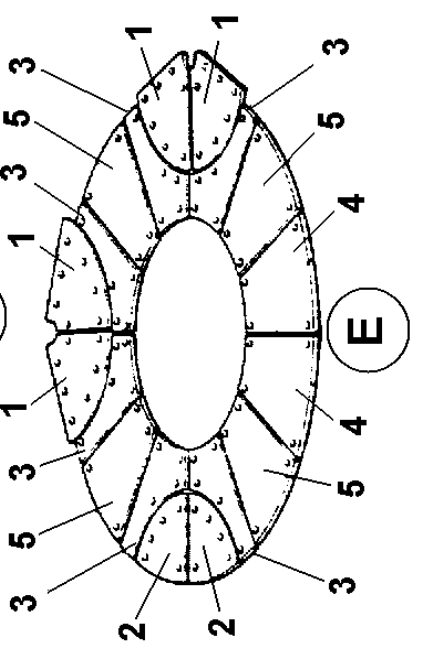
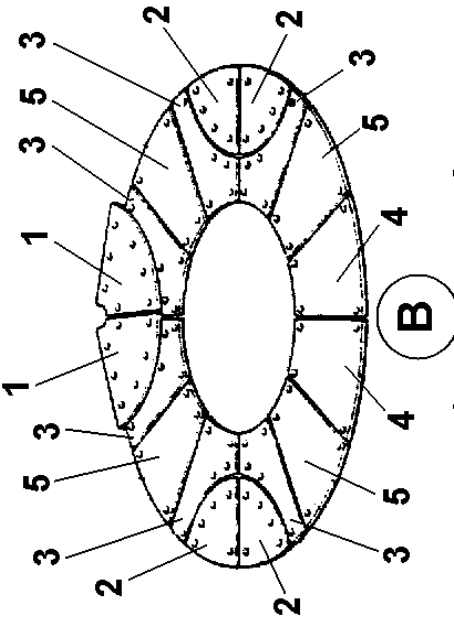
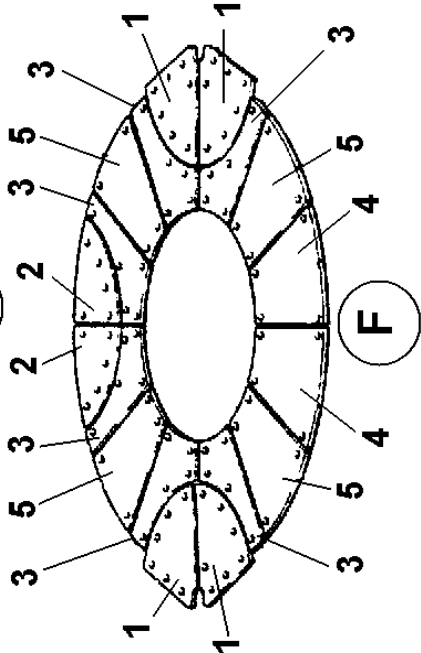
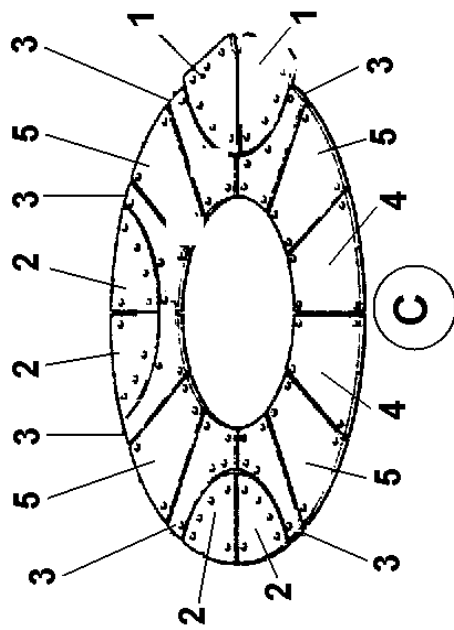



**PAN BASE WEAR PLATES ASSEMBLY****A - 3**

Item	Part no	Serial no	Description	Qty
<b>PAN WITH 2 DOORS-REFS D, E &amp; F</b>				
1	514421300		Door Wearing Plate LH	2
1A	514421300		Door Wearing Plate RH	2
1B	52S05K		Screw C'sunk	28
1C	17S06		Washer Spring	28
1D	7S05		Nut	28
2	514421400		Modification to Door Wear Plate LH	1
2A	514421400		Modification to Door Wear Plate RH	1
2B	52S05G		Screw C'sunk	10
2C	17S06		Washer Spring	10
2D	7S05		Nut	10
3	514421500		Bottom Wear Plate-Door Opening LH	3
3A	514421500		Bottom Wear Plate-Door Opening RH	3
3B	52S05G		Screw C'sunk	12
3C	17S06		Washer Spring	12
3D	7S05		Nut	12
3E	52S05J		Screw C'sunk	12
3F	105S05		Washer Tapered	6
3G	17S06		Washer Spring	12
3H	7S05		Nut	12
3J	52S05L		Screw C'sunk	6
3K	17S06		Washer Spring	6
3L	7S05		Nut	6
4	514421600		Bottom Wearing Plate 33'	2
4A	52S05G		Screw C'sunk	4
4B	17S06		Washer Spring	4
4C	7S05		Nut	4
4D	52S05J		Screw C'sunk	4
4E	105S05		Washer Tapered	2
4F	17S06		Washer Spring	4
4G	7S05		Nut	4
5	514421700		Bottom Wearing Plate 24'	4
5A	52S05G		Screw C'sunk	8
5B	17S06		Washer Spring	8
5C	7S05		Nut	8
5D	52S05J		Screw C'sunk	8
5E	17S06		Washer Spring	8
5F	7S05		Nut	8

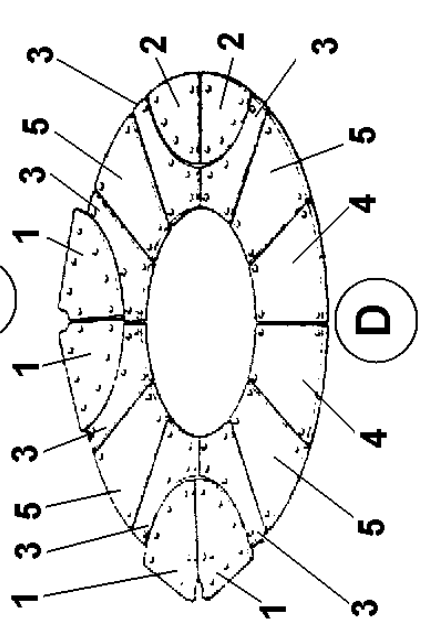
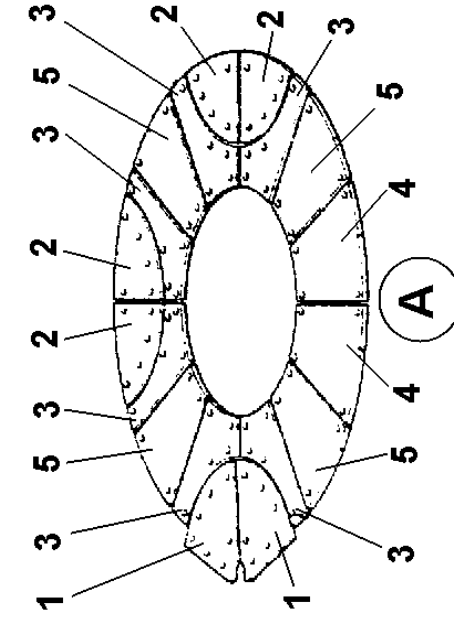
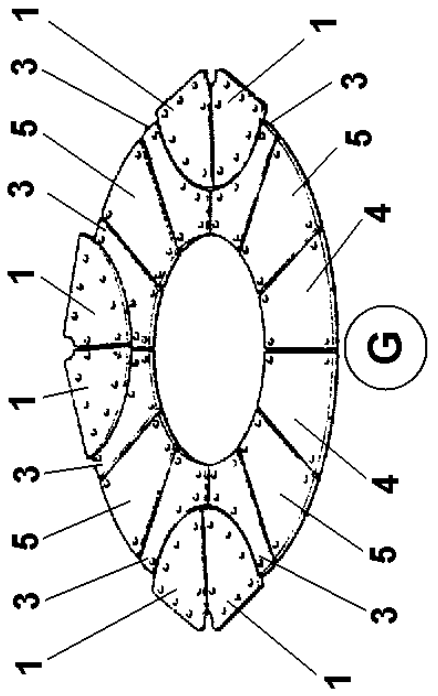
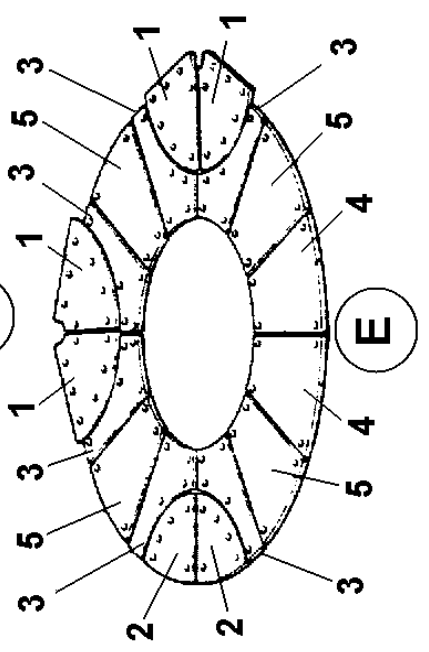
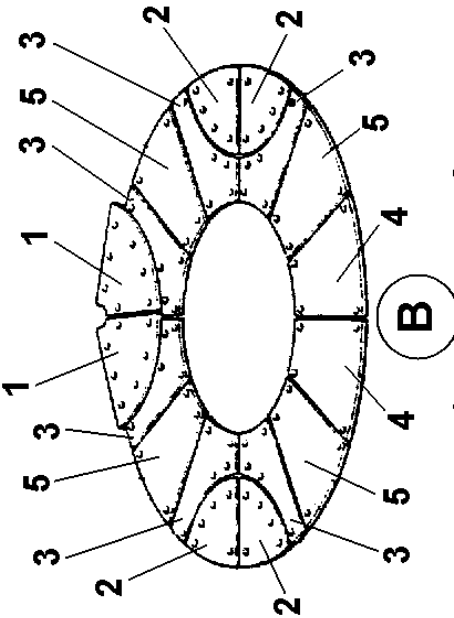
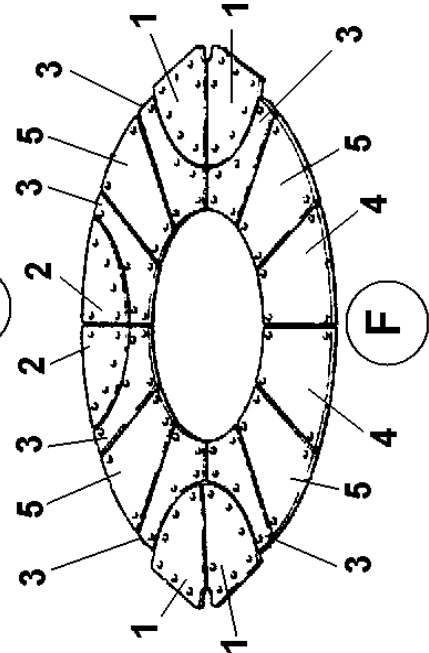
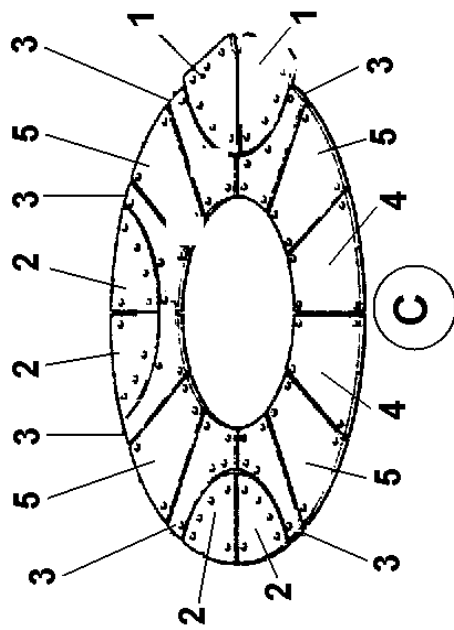

**PAN BASE WEAR PLATES ASSEMBLY****A - 3**

Item	Part no	Serial no	Description	Qty
<b>PAN WITH 3 DOORS-REF G</b>				
1	514421300		Door Wearing Plate LH	3
1A	514421300		Door Wearing Plate RH	3
1B	52S05K		Screw C'sunk	42
1C	17S06		Washer Spring	42
1D	7S05		Nut	42
3	514421500		Bottom Wear Plate-Door Opening LH	3
3A	514421500		Bottom Wear Plate-Door Opening RH	3
3B	52S05G		Screw C'sunk	12
3C	17S06		Washer Spring	12
3D	7S05		Nut	12
3E	52S05J		Screw C'sunk	12
3F	105S05		Washer Tapered	6
3G	17S06		Washer Spring	12
3H	7S05		Nut	12
3J	52S05L		Screw C'sunk	6
3K	17S06		Washer Spring	6
3L	7S05		Nut	6
4	514421600		Bottom Wearing Plate 33'	2
4A	52S05G		Screw C'sunk	4
4B	17S06		Washer Spring	4
4C	7S05		Nut	4
4D	52S05J		Screw C'sunk	4
4E	105S05		Washer Tapered	2
4F	17S06		Washer Spring	4
4G	7S05		Nut	4
5	514421700		Bottom Wearing Plate 24'	4
5A	52S05G		Screw C'sunk	8
5B	17S06		Washer Spring	8
5C	7S05		Nut	8
5D	52S05J		Screw C'sunk	8
5E	17S06		Washer Spring	8
5F	7S05		Nut	8

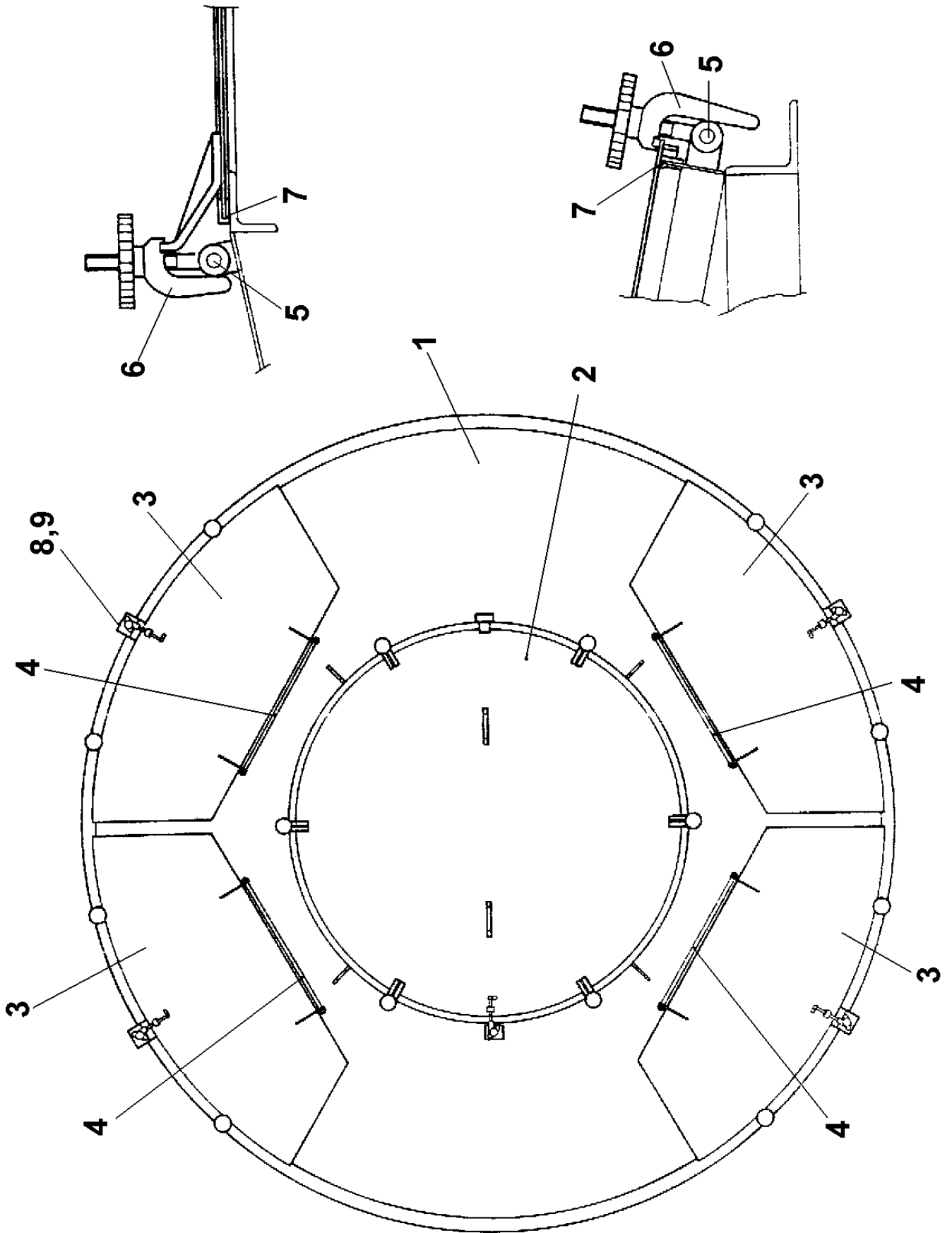

**PAN COVERS ASSEMBLY****A - 4**

<b>Item</b>	<b>Part no</b>	<b>Serial no</b>	<b>Description</b>	<b>Qty</b>
1	514436600		Cover Frame	1
1A	8S05D		Bolt	12
1B	105S05		Washer Tapered	12
1C	7S05		Nut	12
2	514436700		Cover Central	1
3	514436800		Hinged Lid	4
4	514425100		Hinge Shaft	4
5	514425300		Clip Pin	14
5A	267S07		Washer Flat	28
5B	44S13H		Pin Split	28
6	314412000		Linadaptor c/w Eye Bolt & H/wheel	14
7	394910000		Neoprene Extrusion 17m Long	1
8	365126000		Interlock Assembly	5
8A	8S02E		Bolt	10
8B	267S04		Washer Flat	10
8C	61S02		Nut Binx	10
8D	11S02AA		Screw Set	10
8E	267S04		Washer Flat	10
9	365126001		Bolt Lock Type "K" (for Interlock)	5

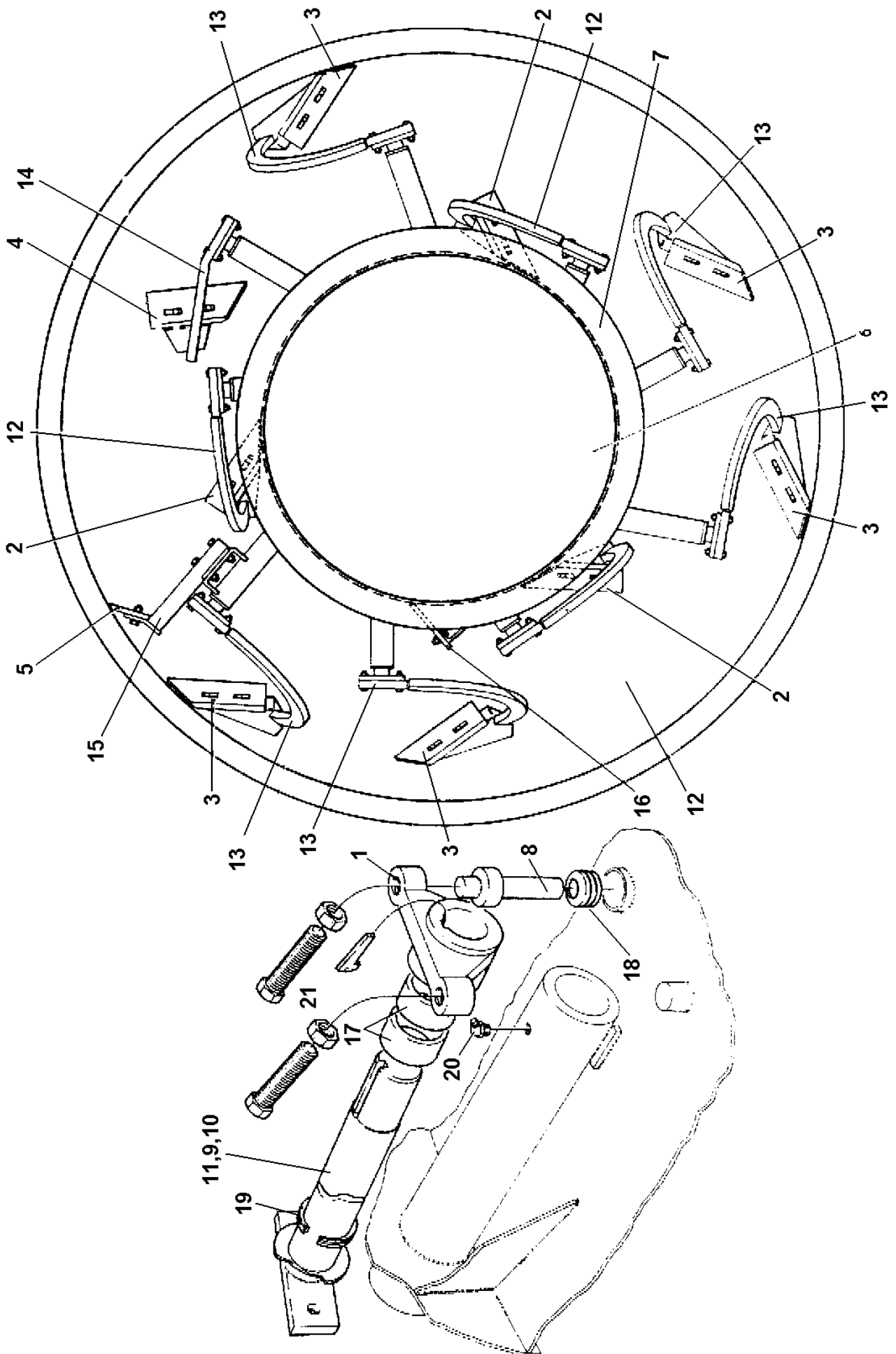

**ROTOR AND BLADES ASSEMBLY****B-1**

Item	Part no	Serial no	Description	Qty
1	514401700	upto S/Number 999	Rotor Arm Rocker Shaft	9
1A	11S06M		Screw Set	18
1B	7S06		Nut	18
2	514295800		Paddle Blade Inner	3
2A	514162400		Bolt, Square Head	6
2B	41S07		Washer Spring	6
2C	104S05		Nut Plain, Alternative to Ref 2E	6
2D	514162500		Washer for Paddle Blade, Special	6
2E	192S05		Nut Binx 1/2" UNC, see Ref 2C	6
3	514295400		Paddle Blade LH	5
3A	514162400		Bolt, Square Head	10
3B	41S07		Washer Spring	10
3C	104S05		Nut Plain, Alternative to Ref 3E	10
3D	514162500		Washer for Paddle Blade, Special	10
3E	192S05		Nut Binx 1/2" UNC, see Ref 3C	10
4	514295500		Intermediate Paddle Blade	1
4A	514162400		Bolt, Square Head	2
4B	41S07		Washer Spring	2
4C	104S05		Nut Plain, Alternative to Ref 4E	2
4D	514162500		Washer for Paddle Blade, Special	2
4E	192S05		Nut Binx 1/2" UNC, see Ref 4C	2
5	514157800		Outer Scraper Blade	1
5A	8S06F		Bolt	2
5B	267S09		Washer Flat	2
5C	17S08		Washer Spring	2
5D	7S06		Nut	2
6	514415800		Rotor Cover	1
6A	11S03A		Screw Set	16
6B	17S04		Washer Spring	16
7	514420100		Rotor	1
8	514402000		Shock Absorber Pin	9
9	514401500		Welded Assembly of Rotor Arm Shaft	3
10	514415400		Welded Assembly of Rotor Arm Shaft Long	3
11	514420000		Welded Assembly of Rotor Arm Shaft 690	3
12	514410900		Inner Mixing Blade Arm	3
12A	8S05G		Bolt	6
12B	61S05		Nut Binx	6
13	514411000		Outer Mixing Blade Arm	5
13A	8S05G		Bolt	10

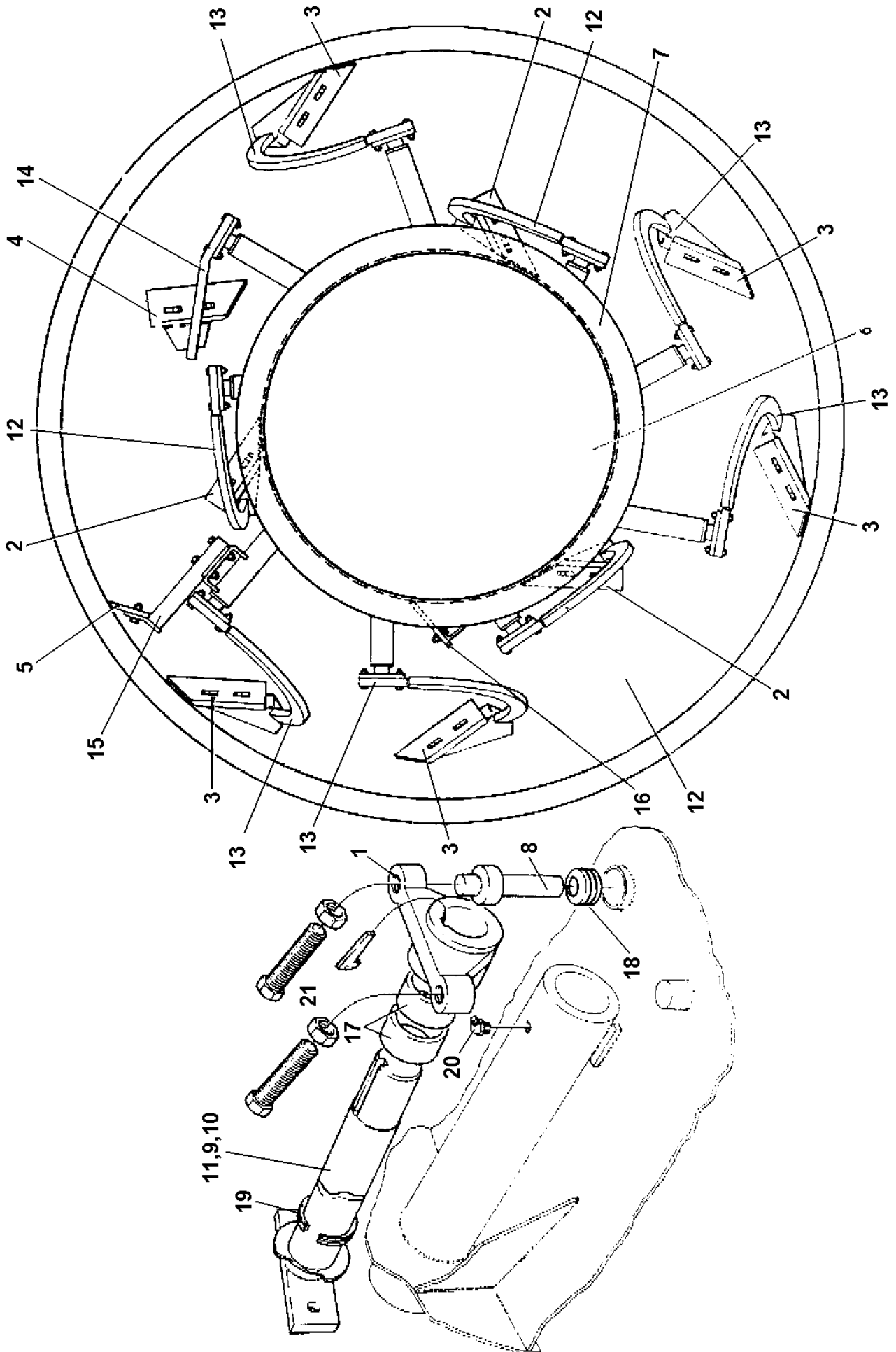



**ROTOR AND BLADES ASSEMBLY****B-1**

<b>Item</b>	<b>Part no</b>	<b>Serial no</b>	<b>Description</b>	<b>Qty</b>
13B	61S05		Nut Binx	10
14	514400900		Intermediate Mixing Blade Arm	1
14A	8S05G		Bolt	2
14B	61S05		Nut Binx	2
15	514415900		Outer Scraper Arm	1
15A	8S06F		Bolt	2
15B	267S09		Washer Flat	2
15C	17S08		Washer Spring	2
15D	7S06		Nut	2
16	514400700		Inner Scraper Blade	1
16A	8S06F		Bolt	2
16B	267S09		Washer Flat	2
16C	17S08		Washer Spring	2
16D	7S06		Nut	2
17	514408600		Rotor Arm Bush	18
18	420475000		Disc Springs	234
19	417782000		V' Ring Seal	9
20	333602010		45' 1/4 BSP Grease Nipple	9
21	304312050		Key Gib Head	9
	514406200		Wear Plates for Arms not illustrated	

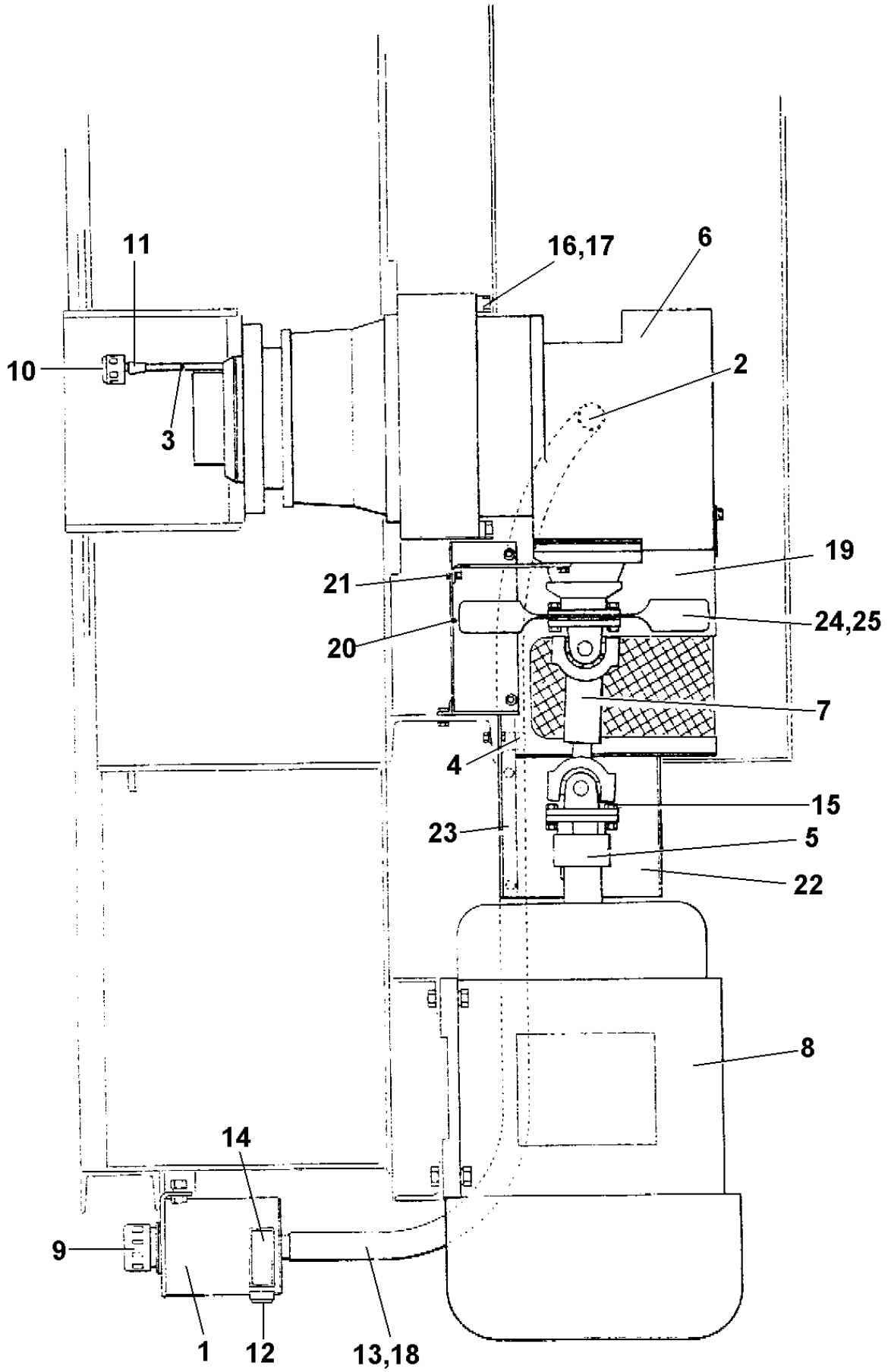

**ROTOR TRANSMISSION ASSEMBLY****B - 2**

Item	Part no	Serial no	Description	Qty
1	514419100		Oil Reservoir	1
1A	11S04D		Screw Set	2
1B	17S05		Washer Spring	2
1C	7S04		Nut	2
2	514418800		Gearbox Adaptor	1
3	514418900		Breather Tube	1
4	514419000		Hose Clip	1
4A	11S02C		Screw Set	2
4B	267S04		Washer Flat	2
4C	17S03		Washer Spring	2
4D	7S02		Nut	2
5	555552200		Drive Flange	1
5A	57S06D2		Screw Grub Cone Point	1
6	254126000		Transmission	1
6A	8S06H		Bolt	9
6B	17S08		Washer Spring	9
7	412816000		Prop Shaft	1
7A	28S04J		Screw Set	4
7B	10S48		Washer Flat	4
7C	87S04		Nut Binx	4
8	202433000		Motor Electric	1
8A	11S06K		Screw Set	4
8B	267S09		Washer Flat	4
8C	61S06		Nut Binx	4
9	220252000		Oil Reservoir Breather	1
10	220282000		Gearbox Breather	1
11	242102100		Reducing Socket	1
12	257103000		Sight Glass	1
13	260910010		Hose (1.8m long)	1
14	514440500		Label Oil Level	1
15	555177200		Special Bolt	4
15A	10S48		Washer Flat	4
15B	87S04		Nut Binx	4
16	514440300		Drive Unit Stud	3
16A	17S08		Washer Spring	3
16B	7S06		Nut	3
17	514440400		Drive Unit Collar	3
18	143152000		Hose Clip	2
19	514441700		Fan Shroud	1
19A	11S04A		Screw Set	1
19B	17S05		Washer Spring	1

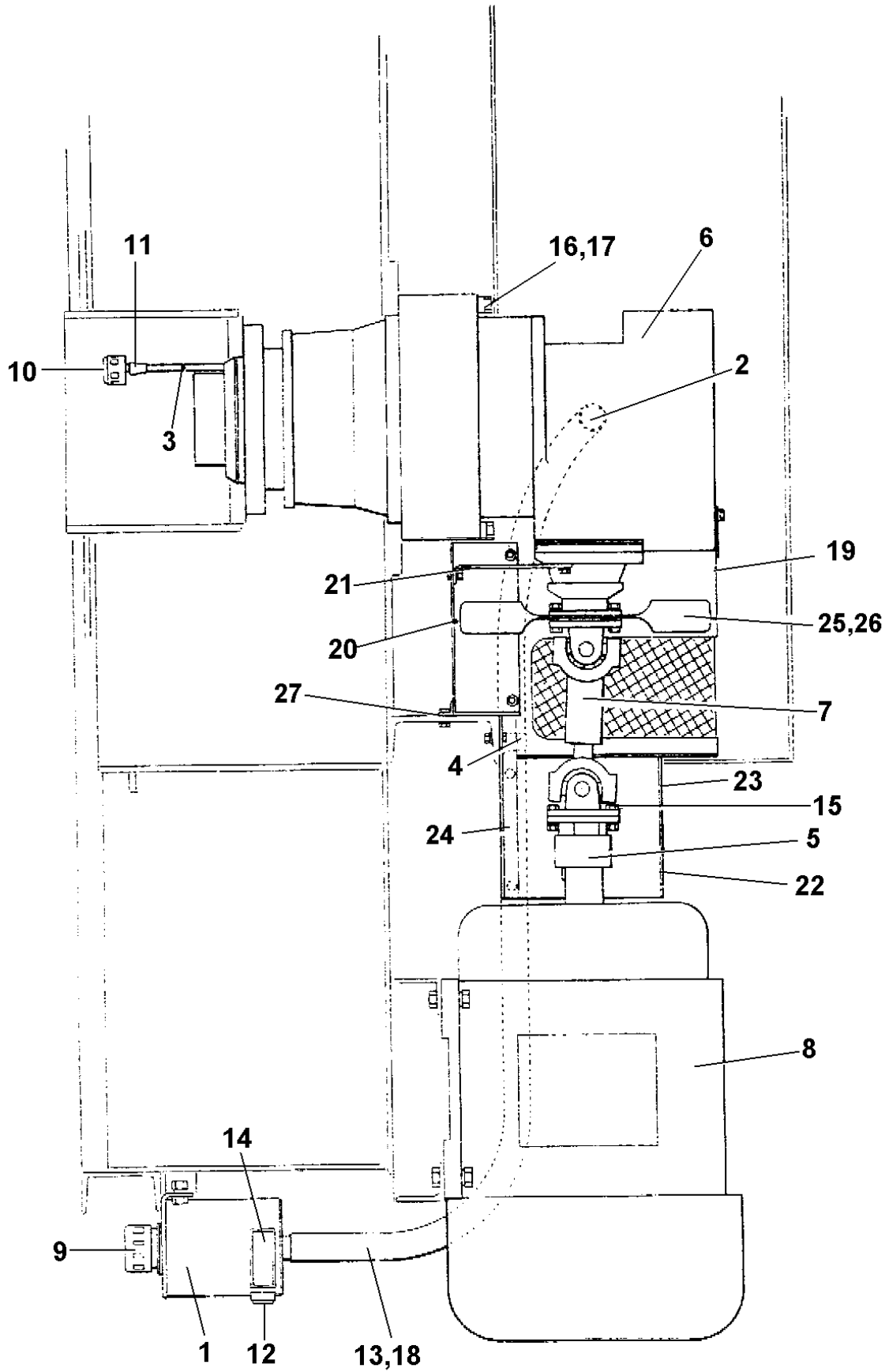

**ROTOR TRANSMISSION ASSEMBLY****B - 2**

<b>Item</b>	<b>Part no</b>	<b>Serial no</b>	<b>Description</b>	<b>Qty</b>
20	514441800		Fan Shroud Support	1
20A	11S04A		Screw Set	4
20B	17S05		Washer Spring	4
20E	7S04		Nut	2
21	514419000		Fan Shroud Stay	2
21A	11S04C		Screw Set	2
21B	17S05		Washer Spring	2
21C	7S04		Nut	2
22	514442000		Prop Shaft Guard Outer	1
22A	11S02AA		Screw Set	4
22B	17S03		Washer Spring	4
23	514442300		Prop Shaft Guard Inner	1
23A	11S02AA		Screw Set	4
23B	17S03		Washer Spring	4
24	514442100		Prop Shaft Guard Support	1
24A	11S04D		Screw Set	4
24B	105S03		Washer Taper	4
24C	17S05		Washer Spring	4
24D	7S04		Nut	4
25	514441100		Cooling Fan	1
26	514441200		Fan Spacer	1
27	514442400		Cover Plate	1
27A	11S04C		Screw Set	4
27B	17S05		Washer Spring	4
27C	7S04		Nut	4

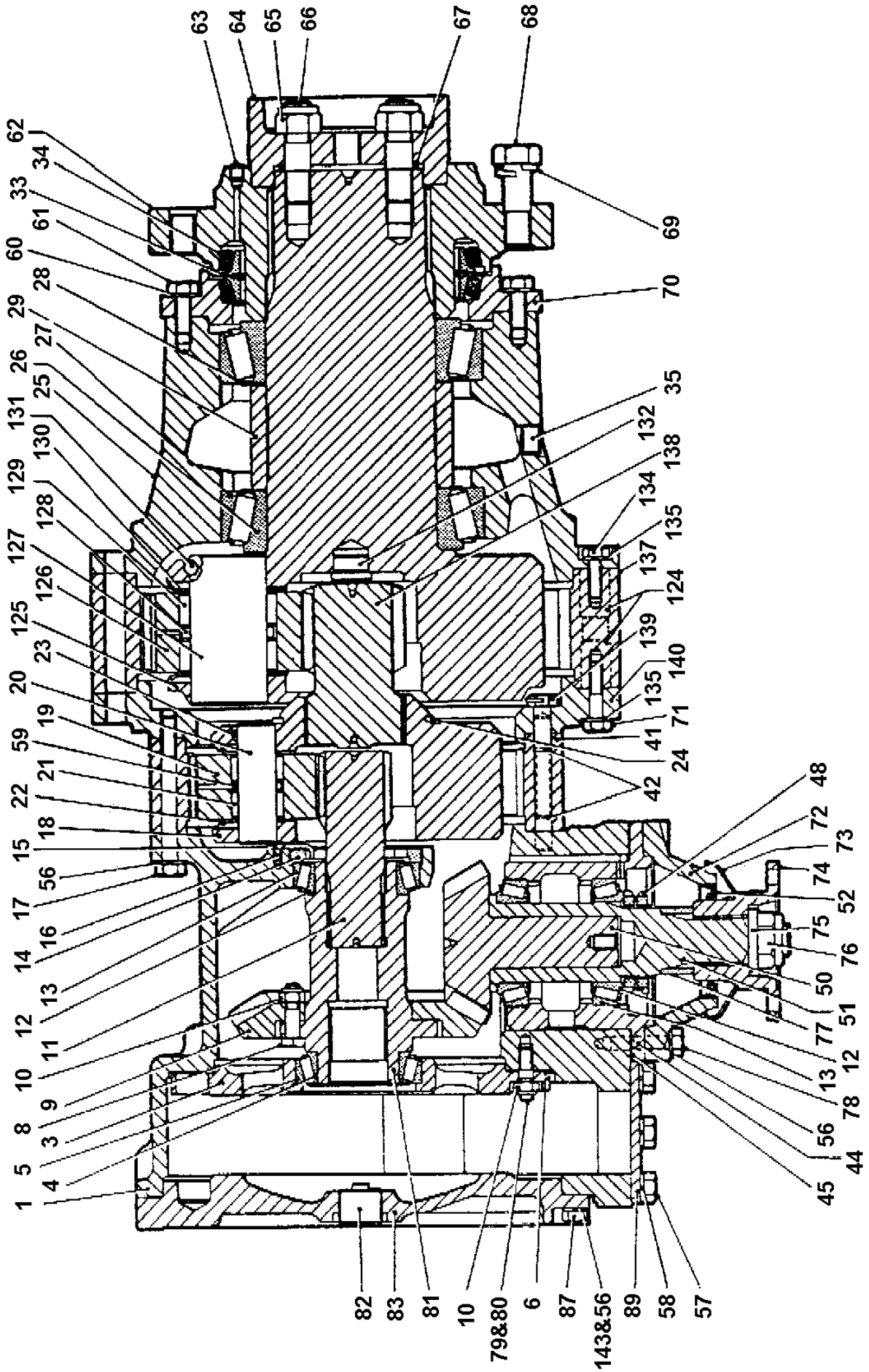

**GEARBOX ASSEMBLY****B - 3**

Item	Part no	Serial no	Description	Qty
1	254126001		Casing Main	1
3	254126002		Plate-Inner Brake	1
4	254126003		Cone-Outer Bearing	1
5	254126004		Cup-Outer Bearing	1
6	254126005		Shim-Quantity as Required	A/R
6	254126006		Shim-Quantity as Required	A/R
8	254126007		Bolt	8
9			Wheel Spiral Bevel	1
10	254126008		Nut	18
11	254126009		Pinion-Sun	1
12	254126010		Cone-Bearing	3
13	254126011		Cup-Bearing	3
14	254126012		Nut-Bearing Adjusting	1
15	254126013		Washer-Tab	1
16	254126014		Screw	2
17	254126015		Setscrew	8
18			Carrier-Planet	1
19	254126016		Gear	3
20	254126017		Pin	3
21	254126018		Roller-Needle	132
22	254126019		Washer-Thrust	6
23	254126020		Key-Ball	3
24	254126021		Circlip	1
25	254126022		Housing-Bearing	1
26	254126023		Cone-Bearing	2
27	254126024		Cup-Bearing	2
28	254126025		Shim-Quantity as Required	A/R
28	254126026		Shim-Quantity as Required	A/R
29	254126028		Spacer	1
33	254126029		Seal-Oil	1
34	254126030		O' Ring	2
35	254126031		Plug	1
41	254126032		Gear-Annulus	1
42	254126033		Dowel	4
44	254126034		Housing	1
45	254126035		Shim-Quantity as Required	A/R
45	254126036		Shim-Quantity as Required	A/R
48	254126037		Locknut	2
49	254126038		Lockplate	1
50			Pinion-Spiral Bevel	1
51			Sleeve	1

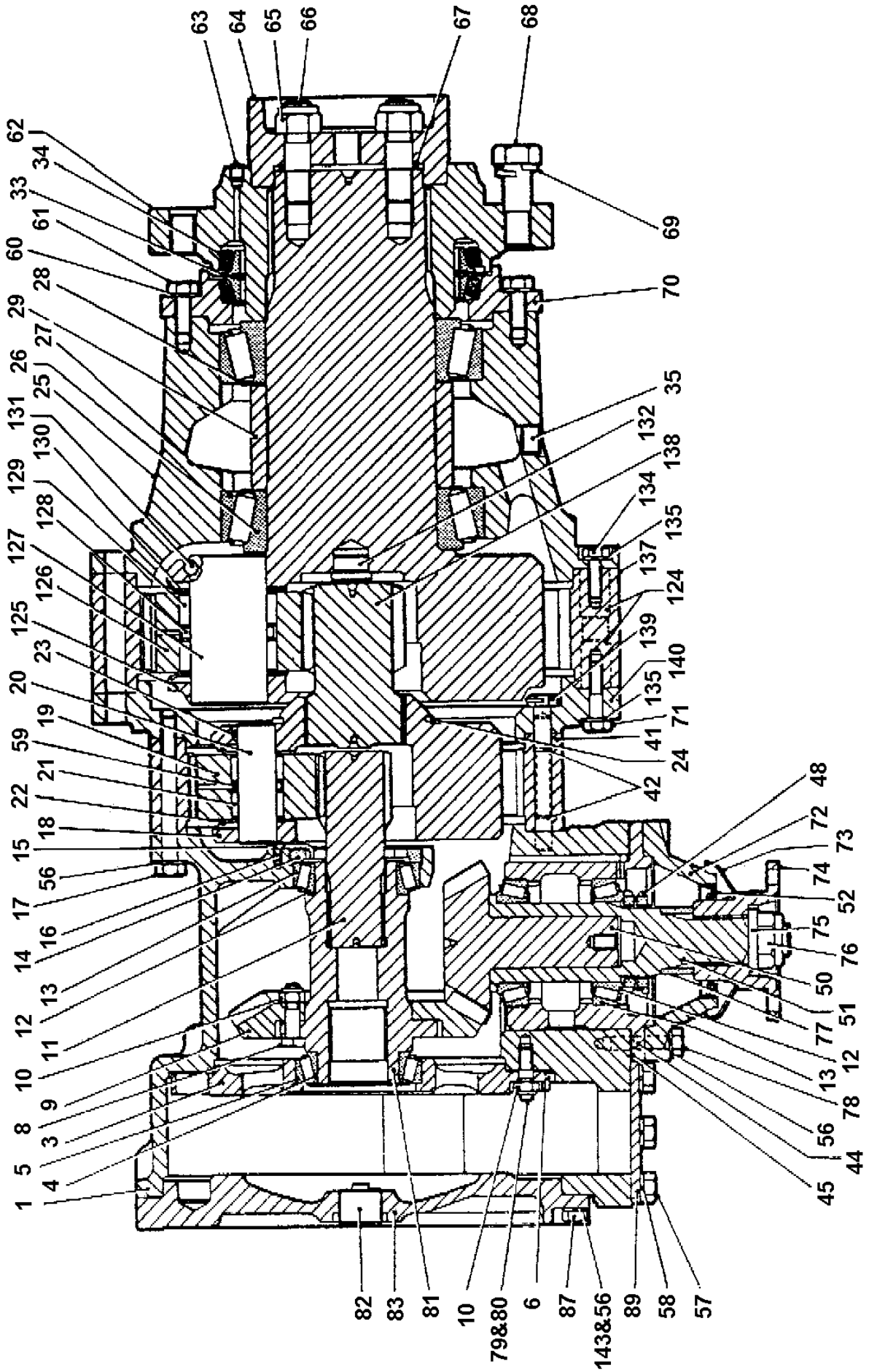



**GEARBOX ASSEMBLY****B - 3**

Item	Part no	Serial no	Description	Qty
52	254126039		Oil-Seal	1
56	254126040		Washer-Spring	16
57	254126041		Screwset	4
58	254126042		Washer-Spring	4
59	254126043		Spacer	3
60	254126044		Washer-Spring	8
61	254126045		Screwset	8
62	254126046		Ring-Drive	1
63	254126047		Plug	1
64	254126048		Cap End	1
65	254126049		Nut	4
66	254126050		Stud	4
67	254126051		O' Ring	1
68	254126052		Screwset	16
69	254126053		Washer-Spring	16
70	254126054		Housing Seal	1
71	254126055		Screwset	2
72	254126056		Housing-Seal	1
73	254126083		Cover Dust	1
74	254126057		Flange-Coupling	1
75	254126058		Washer	1
76	254126059		Nut	1
77	254126060		Spacer	1
78	254126061		Screwset	8
79	254126084		Stud (short)	5
80	254126085		Stud (long)	5
81	254126086		Shaft	1
82	254126087		Plug-Magnetic Drain	1
83	254126088		Cover-Brake	1
87	254126062		Screwset	12
89	254126063		Cover	1
124	254126064		Dowel	4
125	254126065		Planet-Carrier	1
126	254126066		Gear	3
127	254126067		Planet Pin	3
128	254126068		Spacer	3
129	254126069		Needle Roller	156
130	254126070		Side Washer	6
131	254126071		Ball Key	3
132	254126072		Thrust Button	1
134	254126073		Screwset	2

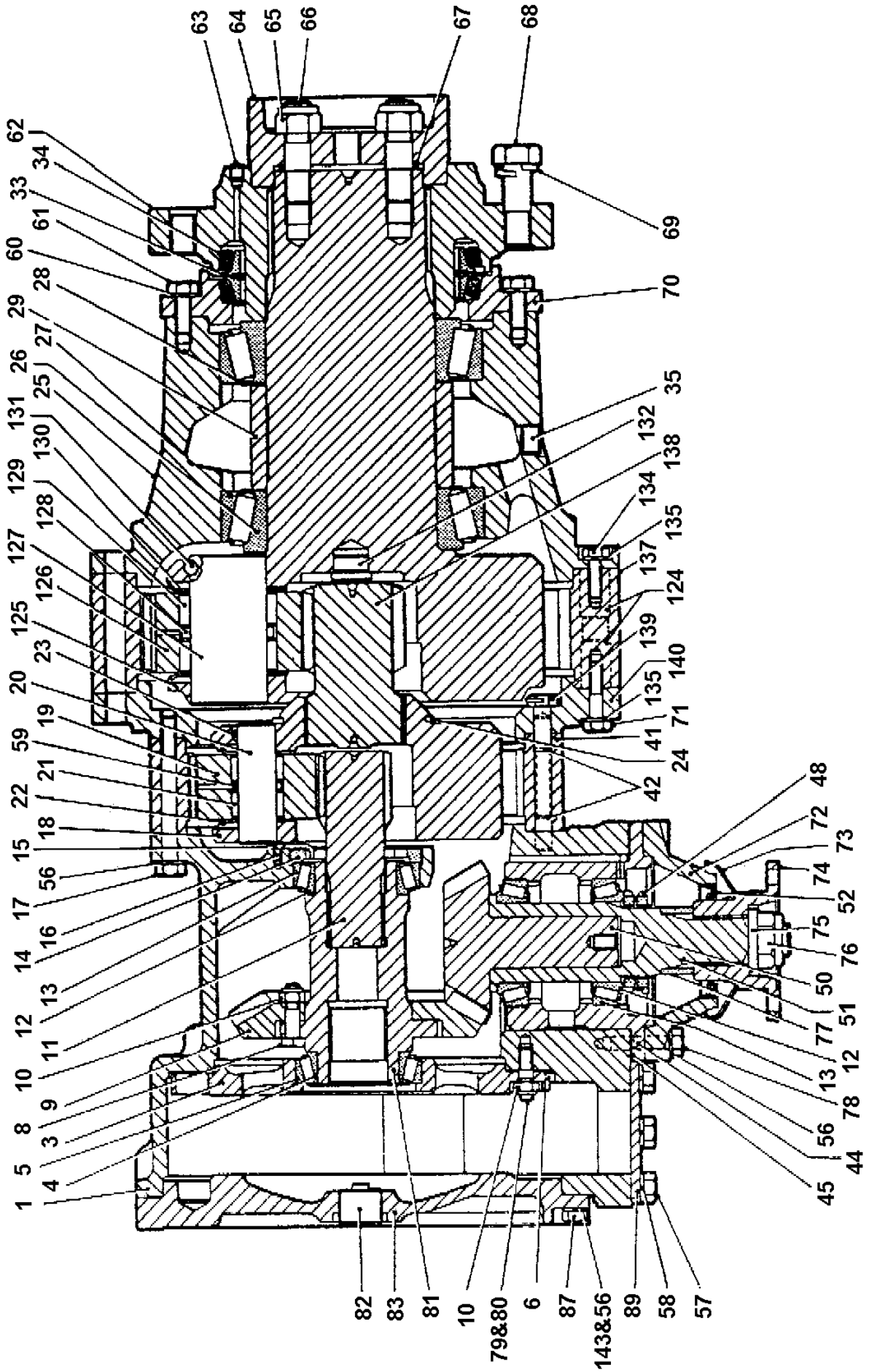

**GEARBOX ASSEMBLY****B - 3**

Item	Part no	Serial no	Description	Qty
135	254126074		Washer Spring	4
137	254126075		Annulus	1
138			Sun Pinion	1
139	254126076		Screwset	4
140	254126077		Adaptor	1
143	254126078		Dowty Washer	4

The following items are supplied as assemblies only:-

- 254126079    1) Spiral Bevel Wheel Ref 9 and Spiral Bevel Pinion and Sleeve Ref 50 and 51. Collective Assembly No 688500384
- 254126080    2) Planet Carrier Ref 18 and Sun Gear/Pinion Ref 138 Assembly No 670029285

The following items may also be supplied as assemblies:-

- 254126081    1) Second Stage Planet Carrier Assembly 687300315 comprising items 18 to 24 inclusive, 59 and 138
- 254126082    3) Third Stage Planet Carrier Assembly 687400305 comprising items 26, 125 to 132 inclusive.

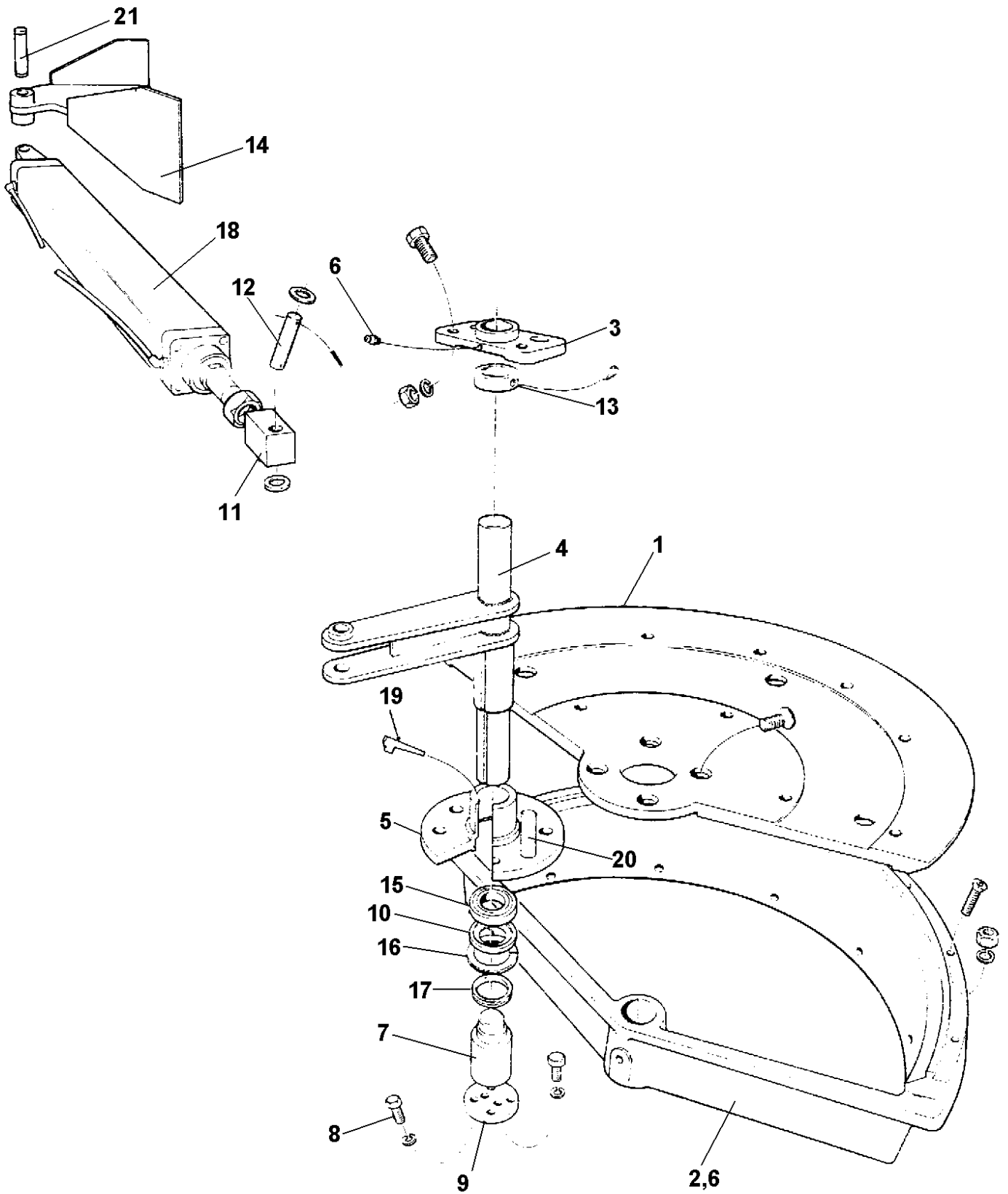

**DISCHARGE DOOR ASSEMBLY****C - 1**

Item	Part no	Serial no	Description	Qty
1	514435200		Discharge Door	1
1A	52S06J		Screw Set Csk Hd	4
2	514422400		Discharge Door Outlet	1
2A	52S05K		Screw Set Csk Hd	3
2B	17S06		Washer Spring	3
2C	7S05		Nut	3
3	514422500		Top Bearing	1
3A	11S06K		Screw Set	4
3B	267S09		Washer Flat	2
3C	17S08		Washer Spring	4
3D	7S06		Nut	4
4	514422600		Door Shaft	1
5	514435300		Discharge Door Hub	1
6	333104020		Grease Nipple	2
7	514422900		Door Journal	1
8	514423500		Screw Set Special	4
8A	17S08		Washer Spring	4
9	514423000		End Plate	1
9A	11S06F		Screw Set	4
9B	17S08		Washer Spring	4
10	514423100		Sealing Ring	1
11	514423600		Rod End, upto S/No 999	1
12	514423200		Rod End Pin	1
12A	267S14		Washer Flat	2
12B	44S17K		Pin Split	2
13	514423300		Collar	1
13A	57S07E2		Screw Grub	1
14	514421000		Air Cylinder Pivot Bracket	1
15	104455020		Bearing Ball	1
16	391703000		Retaining Ring	1
17	417765000		V' Ring Seal	1
18	137108300		Air Cylinder upto S/No 999	1
18A	56S07		Nut Lock	1
19	304318125		Key Gib Head	2
20	353222040		Dowel	2
21	514423800		Rear Pivot Pin upto S/No 999	1
21A	267S14		Washer Flat	2
21B	44S17K		Pin Split	2
22	137100004		Spares Kit for Air Cylinder, not illustr upto S/No 999	1

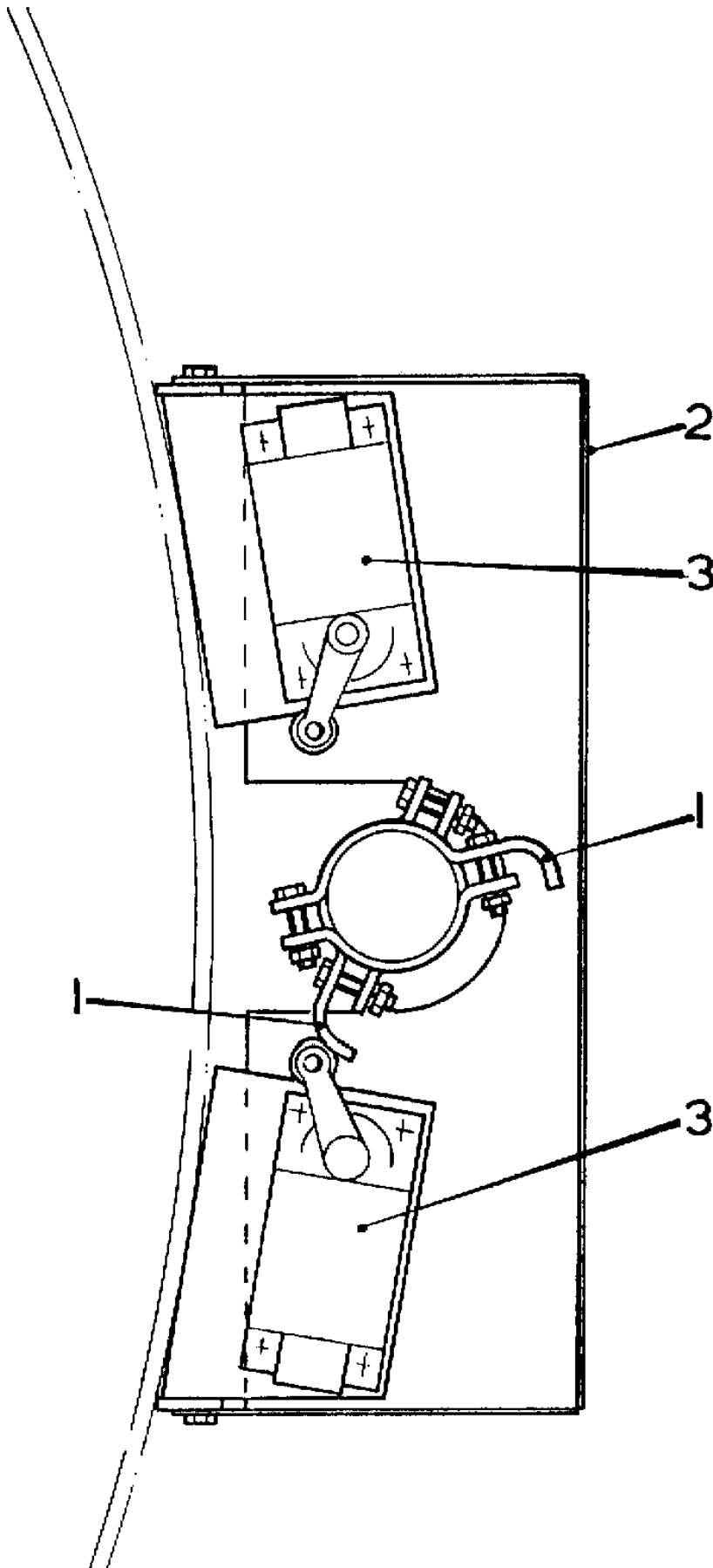

**DOOR LIMIT SWITCH ASSEMBLY****C -2**

<b>Item</b>	<b>Part no</b>	<b>Serial no</b>	<b>Description</b>	<b>Qty</b>
1	514424000		Limit Switch Actuator	2
1A	11S03D		Screw Set	4
1B	17S04		Washer Spring	4
1C	7S03		Nut	4
2	514411400		Limit Switch Cover	1
2A	11S03AA		Screw Set	4
2B	17S04		Washer Spring	4
3	208511000		Limit Switch	2
3A	11S02B		Screw Set	8
3B	17S03		Washer Spring	8
3C	7S02		Nut	8

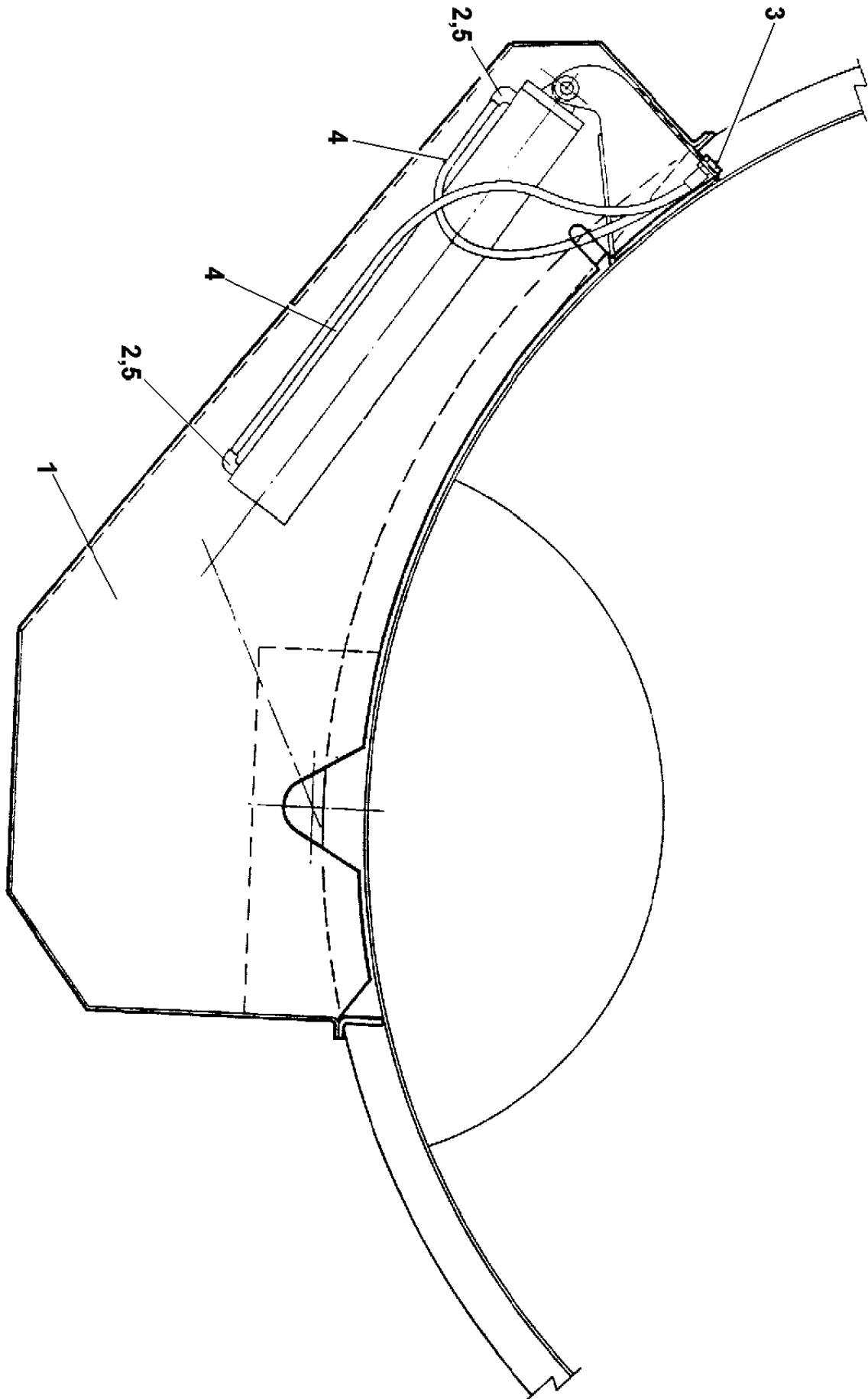



**DOOR CYLINDER GUARD ASSEMBLY****C -3**

<b>Item</b>	<b>Part no</b>	<b>Serial no</b>	<b>Description</b>	<b>Qty</b>
1	514424300		Door Cylinder Guard Assembly	1
1A	11S03B		Screw Set	6
1B	17S04		Washer Spring	6
1C	7S03		Nut	6
2	231091221		Male Stud Adaptor	2
3	231166200		Bulkhead Fitting	1
4	260904370		Nylon Tube (1150mm long)	2
5	240506402		Reducing Bush	2

