

PTGA090304MD

Wideband LDMOS Two-stage Integrated Power Amplifier
2 X 15 W, 48 V, 575 – 960 MHz

Description

The PTGA090304MD is a wideband, two-stage, LDMOS integrated power amplifier. Fabricated with Wolfspeed's 50 V LDMOS process, it incorporates internal matching for operation from 575 MHz to 960 MHz, and dual independent outputs of 15 W each. It is available in a 14-lead plastic overmold package with gull wing leads.

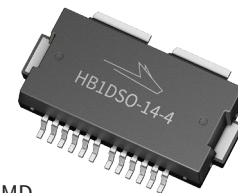

PTGA090304MD
Package PG-HB1DSO-14-4

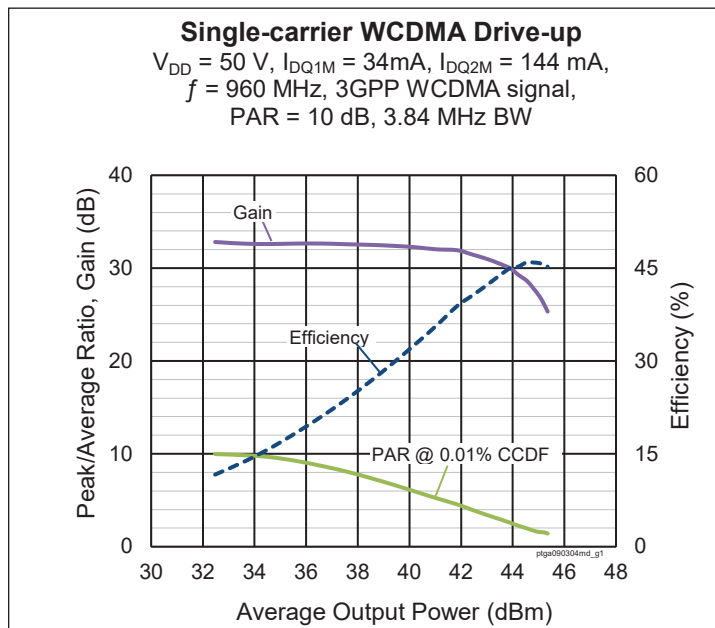

Features

- On-chip matching for broadband operation
- Designed for ultra wideband performance
- Typical CW performance, 960 MHz, 50 V, combined outputs
 - Output power at $P_{1dB} = 45\text{ dBm}$
 - Output power at $P_{3dB} = 45.9\text{ dBm}$
 - Linear Gain at $P_{1dB} = 31\text{ dB}$
 - Efficiency at $P_{1dB} = 48.1\%$
- Capable of handling 10:1 VSWR @ 50 V, 30 W CW output power
- Integrated ESD protection
- Human Body Model Class 1C (per ANSI/ESDA/JEDEC JS-001)
- Integrated temperature compensation
- Pb-free and RoHS compliant

RF Characteristics

Single-carrier WCDMA Specifications (tested in Wolfspeed Class AB production test fixture, combined outputs)

$V_{DD} = 50\text{ V}$, $I_{DQ1M} = 34\text{ mA}$, $I_{DQ2M} = 144\text{ mA}$, $P_{OUT} = 3.9\text{ W avg}$, $f = 960\text{ MHz}$, 3GPP WCDMA signal, channel bandwidth = 3.84 MHz, peak/average = 10 dB @ 0.01% CCDF

Characteristic	Symbol	Min	Typ	Max	Unit
Gain	G_{ps}	30.2	32	—	dB
Drain Efficiency	η_D	17.5	19	—	%
Adjacent Channel Power Ratio	ACPR	—	-44	-46.5	dBc
Output PAR at 0.01% probability on CCDF	OPAR	8.5	9	—	dB

All published data at $T_{CASE} = 25^\circ\text{C}$ unless otherwise indicated

ESD: Electrostatic discharge sensitive device—observe handling precautions!

RoHS
COMPLIANT

Typical Performance, 920 – 960 MHz (tested in Wolfspeed narrowband test fixture)
 $V_{DD} = 50\text{ V}$, $I_{DQ1M} = 34\text{ mA}$, $I_{DQ2M} = 144\text{ mA}$, 3GPP WCDMA signal, channel bandwidth = 3.84 MHz, peak/average = 10 dB @ 0.01% CCDF

Freq [MHz]	Gain [dB]	RL [dB]	Eff [%]	P _{OUT} [dBm]	ACPL [dBc]	ACPU [dBc]	ACP max [dBc]
920	32.9	-37.1	19.8	35.9	-44.7	-44.6	-44.64
940	32.8	-43.6	19.4	35.9	-44.4	-44.1	-44.05
960	32.6	-38.9	19.2	35.9	-43.8	-43.9	-43.75

Typical Broadband Performance, 575 – 960 MHz (tested in Wolfspeed broadband test fixture)
 $V_{DD} = 50\text{ V}$, $I_{DQ1M} = 34\text{ mA}$, $I_{DQ2M} = 144\text{ mA}$, 3GPP WCDMA signal, channel bandwidth = 3.84 MHz, peak/average = 10 dB @ 0.01% CCDF

Freq [MHz]	Gain [dB]	RL [dB]	Eff [%]	P _{OUT} [dBm]	PAR [dB]	ACPL [dBc]	ACPU [dBc]	ACP max [dBc]
575	29.1	-22.3	17.7	35.9	9.2	-37.5	-37.3	-37.30
590	30.1	-22.7	17.8	35.9	9.2	-39.4	-39.5	-39.41
660	32.0	-24.8	18.1	35.9	9.3	-44.5	-45.1	-44.54
746	30.8	-28.0	17.1	35.9	9.5	-45.6	-45.8	-45.57
860	30.2	-23.4	15.8	35.9	9.5	-45.0	-45.5	-45.05
960	30.4	-26.9	15.0	35.9	9.4	-44.0	-44.0	-43.98

DC Characteristics

Characteristics	Conditions	Symbol	Min	Typ	Max	Unit	
Drain-Source Breakdown Voltage	$V_{GS} = 0\text{ V}$, $I_{DS} = 136\text{ }\mu\text{A}$	$V_{(BR)DSS}$	105	—	—	V	
Drain Leakage Current – Stage 1	$V_{DS} = 50\text{ V}$, $V_{GS} = 0\text{ V}$	I_{DSS}	—	—	0.1	μA	
	$V_{DS} = 105\text{ V}$, $V_{GS} = 0\text{ V}$	I_{DSS}	—	—	1.0	μA	
	– Stage 2	$V_{DS} = 50\text{ V}$, $V_{GS} = 0\text{ V}$	I_{DSS}	—	—	0.1	μA
		$V_{DS} = 105\text{ V}$, $V_{GS} = 0\text{ V}$	I_{DSS}	—	—	1.0	μA
Gate Leakage Current – Stage 1	$V_{GS} = 1\text{ V}$, $V_{DS} = 0\text{ V}$	I_{GSS}	—	—	0.1	μA	
	– Stage 2	$V_{GS} = 1\text{ V}$, $V_{DS} = 0\text{ V}$	I_{GSS}	—	0.1	μA	
On-State Resistance – Stage 1	$V_{GS} = 10\text{ V}$, $V_{DS} = 0.1\text{ V}$, $I_D = 24\text{ mA}$	$R_{DS(on)}$	—	22.5	—	Ω	
	– Stage 2	$V_{GS} = 10\text{ V}$, $V_{DS} = 0.1\text{ V}$, $I_D = 136\text{ mA}$	$R_{DS(on)}$	—	2.6	—	Ω
Operating Gate Voltage – Stage 1	$V_{DS} = 50\text{ V}$, $I_{DQ1M} = 34\text{ mA}$	V_{GS1}	—	3.9	—	V	
	– Stage 2	$V_{DS} = 50\text{ V}$, $I_{DQ2M} = 144\text{ mA}$	V_{GS2}	—	3.8	—	V
Fixture Operating Gate Voltage – Stage 1	$V_{DS} = 50\text{ V}$, $I_{DQ1M} = 34\text{ mA}$	V_{GS1}	—	5.8	—	V	
	– Stage 2	$V_{DS} = 50\text{ V}$, $I_{DQ2M} = 144\text{ mA}$	V_{GS2}	—	5.7	—	V

Maximum Ratings

Parameter	Symbol	Value	Unit
Drain-Source Voltage	V_{DSS}	105	V
Gate-Source Voltage	V_{GS}	-6 to +12	V
Operating Voltage	V_{DD}	0 to +55	V
Junction Temperature	T_J	225	°C
Storage Temperature Range	T_{STG}	-65 to +150	°C

1. Operation above the maximum values listed here may cause permanent damage. Maximum ratings are absolute ratings; exceeding only one of these values may cause irreversible damage to the component. Exposure to absolute maximum rating conditions for extended periods may affect device reliability. For reliable continuous operation, the device should be operated within the operating voltage range (V_{DD}) specified above.
2. Parameters values can be affected by end application and product usage. Values may change over time.

Thermal Characteristics

Parameter	Symbol	Value	Unit
Thermal Resistance – Stage 1 ($T_{CASE} = 70^{\circ}\text{C}$, 4 W WCDMA)	$R_{\theta JC}$	7.8	°C/W
– Stage 2 ($T_{CASE} = 70^{\circ}\text{C}$, 4 W WCDMA)	$R_{\theta JC}$	3.3	°C/W

Moisture Sensitivity Level

Level	Test Standard	Package Temperature	Unit
3	IPC/JEDEC J-STD-020	260	°C

Ordering Information

Type and Version	Order Code	Package	Shipping
PTGA090304MD V2 R5	PTGA090304MD-V2-R5	PG-HB1DSO-14-4	Tape & Reel, 500 pcs

Evaluation Boards

Order Code	Frequency	Description
LTN/PTGA090304MD-V2	920 – 960 MHz	Class AB with combined outputs, R04350
LTN/PTGA090304MD-E2	728 – 768 MHz	Class AB with combined outputs, R04350
LTN/PTGA090304MD-E3	575 – 960 MHz	Class AB with combined outputs, R04350

Typical Performance, 920 – 960 MHz (data taken in test fixture)

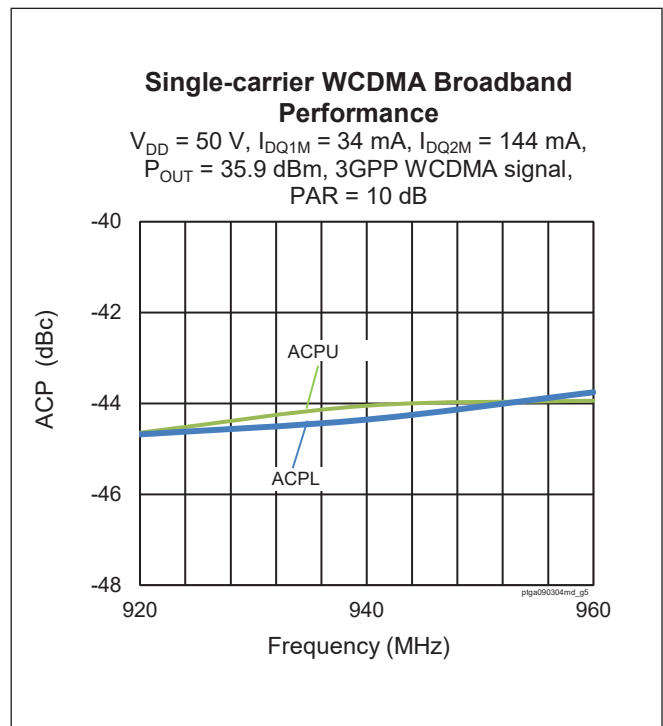
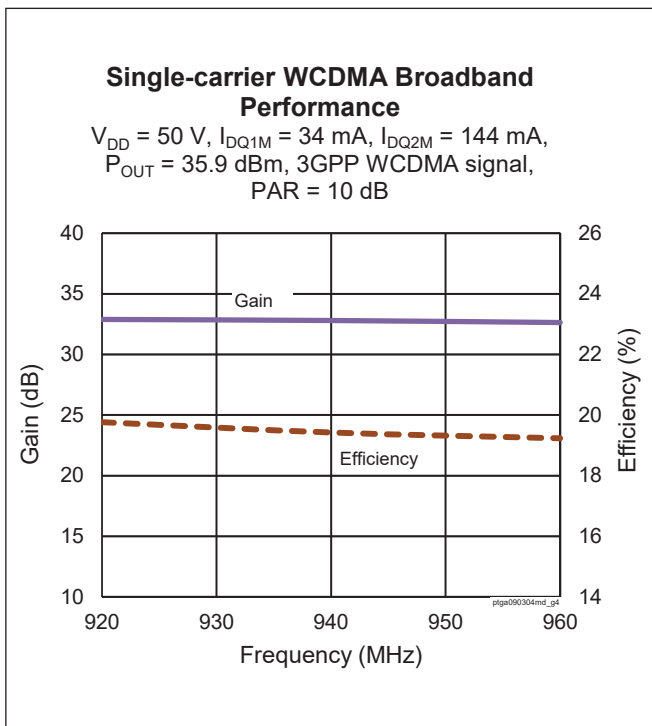
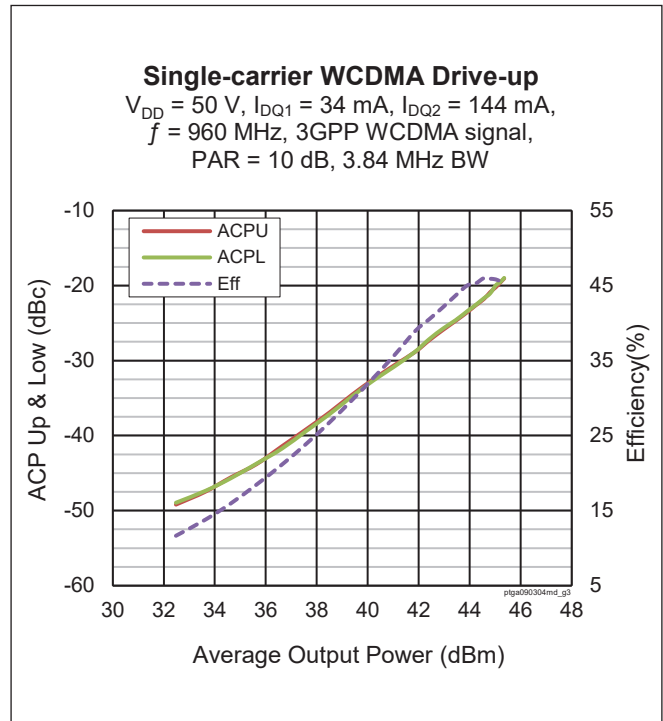
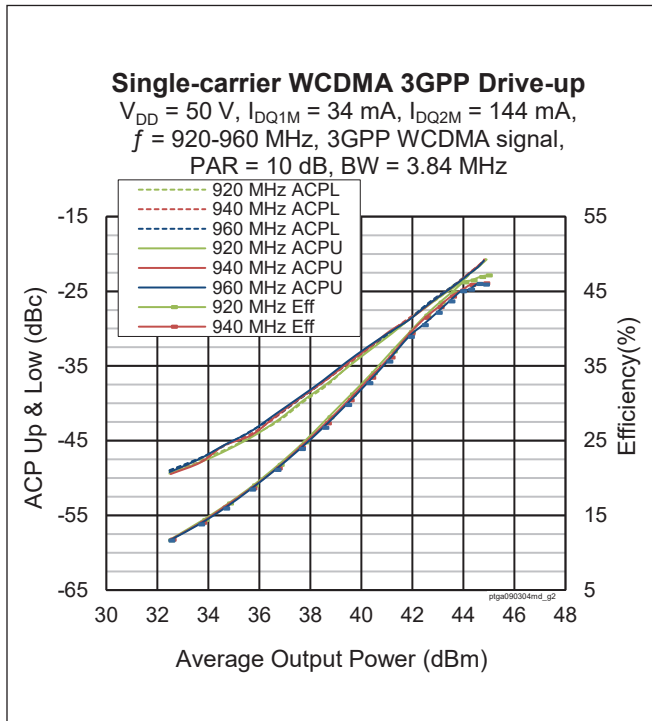

Typical Performance, 920 – 960 MHz (data taken in test fixture)

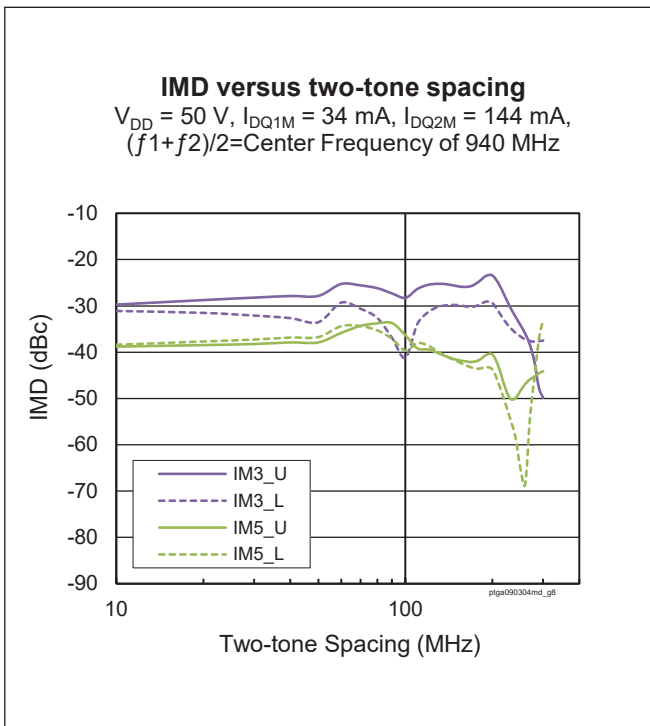
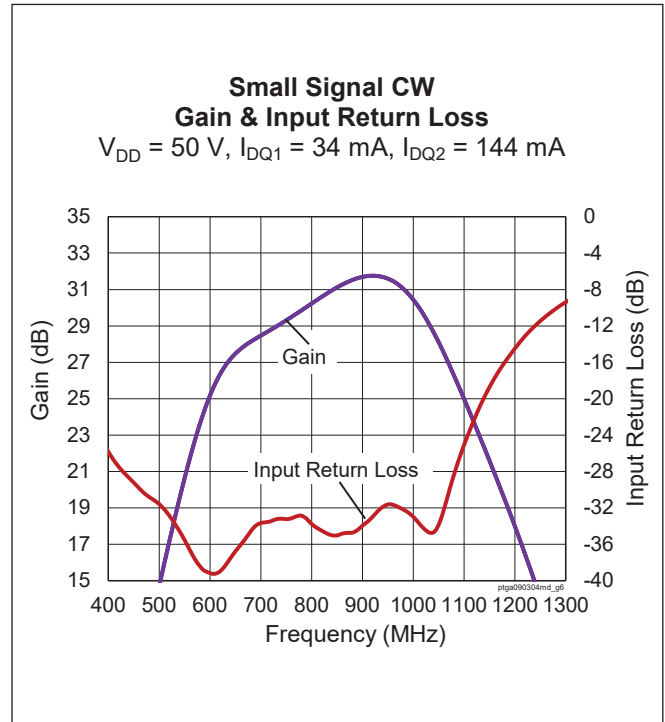
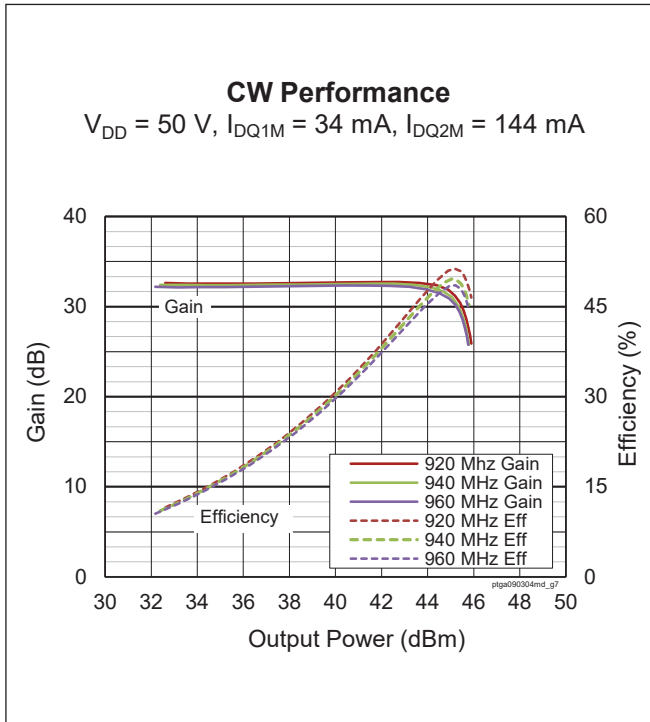

Reference Circuit, 920 – 960 MHz

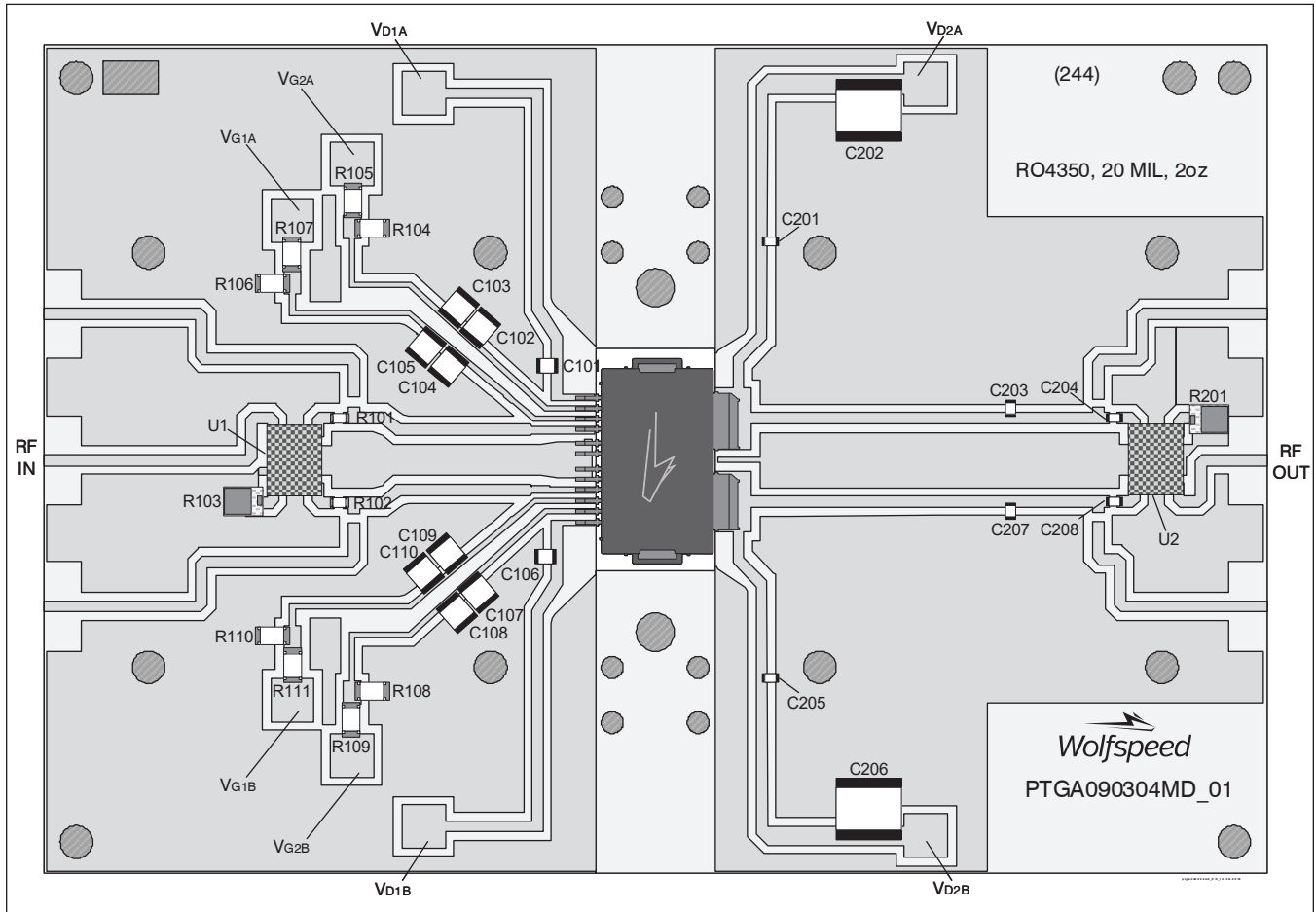

Reference circuit assembly diagram (not to scale)

Reference Circuit Assembly

DUT	PTGA090304MD V2
Test Fixture Part No.	LTN/PTGA090304MD-V2
PCB	Rogers 4350, 0.508 mm [0.020"] thick, 2 oz. copper, $\epsilon_r = 3.66$, $f = 920 - 960$ MHz
Find Gerber files for this test fixture on the Wolfspeed Web site at www.wolfspeed.com/RF	

Components Information

Component	Description	Manufacturer	P/N
C101, C106	Capacitor, 0.1 μ F	TDK Corporation	C3216X7R2A104M160AA
C102, C104, C107, C109	Capacitor, 100 V, 10 μ F	Murata Electronics North America	GRM32EC72A106KE05L
C103, C105, C108, C110	Capacitor, 4.7 μ F	Murata Electronics North America	GRM32ER71H475KA88L
C201, C204, C205, C208	Capacitor, 100 pF	ATC	ATC800A101JT250T
C202, C206	Capacitor, 100 V, 10 μ F	TDK Corporation	C5750X7S2A106M230KB
C203, C207	Capacitor, 0.1 pF	ATC	ATC800A0R1CT250T
R101, R102	Resistor, 0 ohms	Panasonic Electronic Components	ERJ-3GEY0R00V
R103, R201	Resistor, 50 ohms	Anaren	C8A50Z4A
R104, R106, R108, R110	Resistor, 4.3K ohms	Panasonic Electronic Components	ERJ-8GEYJ432V
R105, R107, R109, R111	Resistor, 1K ohms	Panasonic Electronic Components	ERJ-8GEYJ102V
U1, U2	Hybrid coupler	Anaren	X3C07P1-03S

Typical Broadband Performance, 575 – 960 MHz (data taken in test fixture)

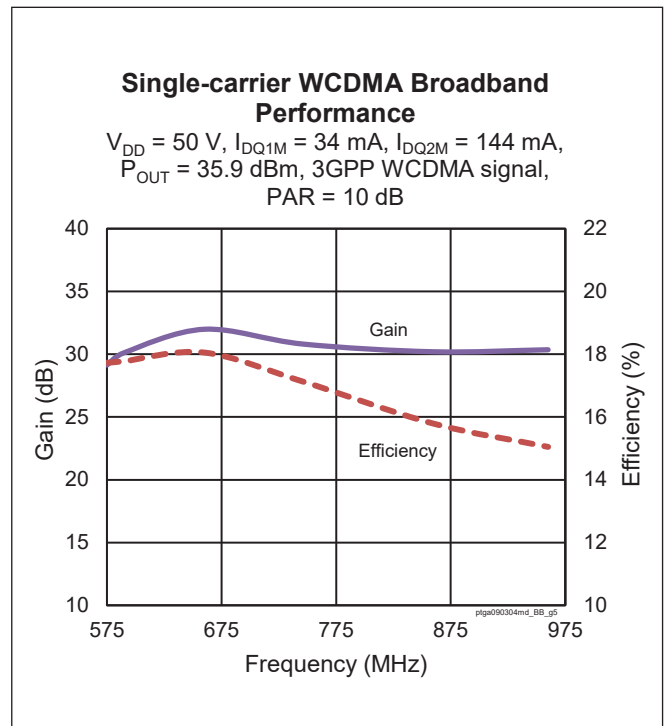
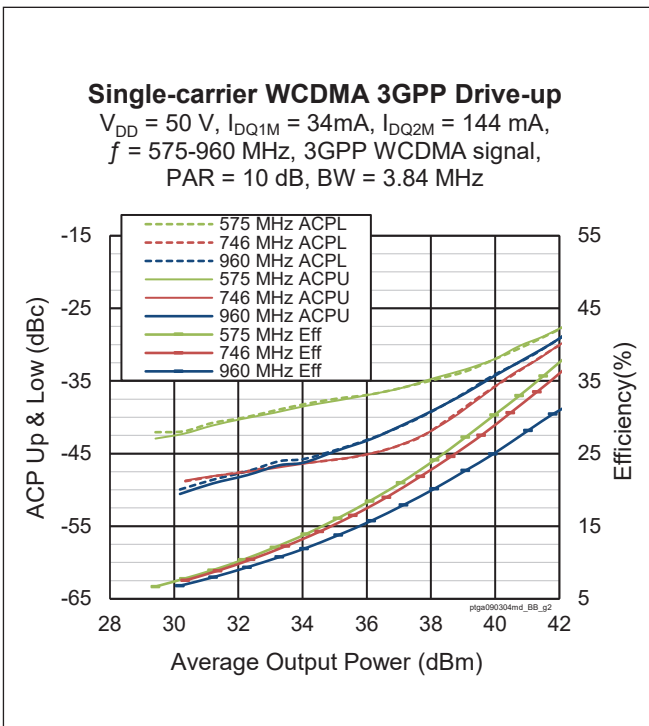
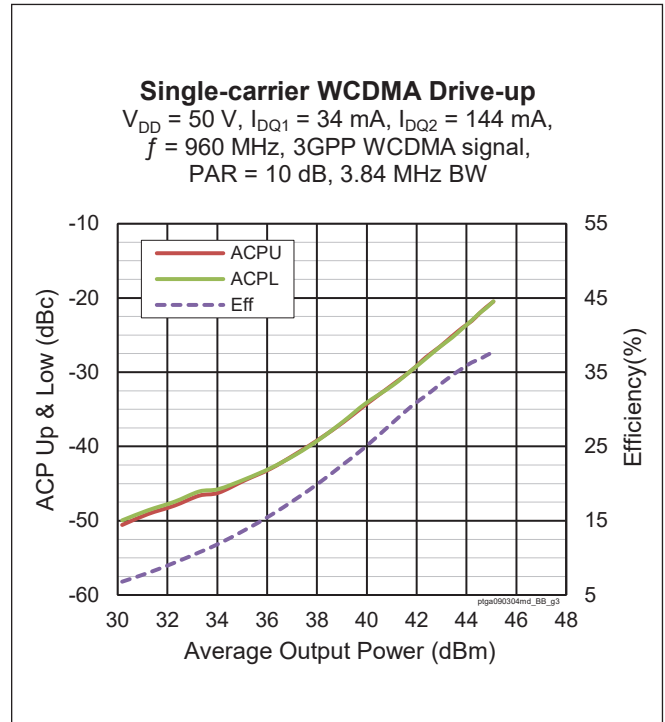
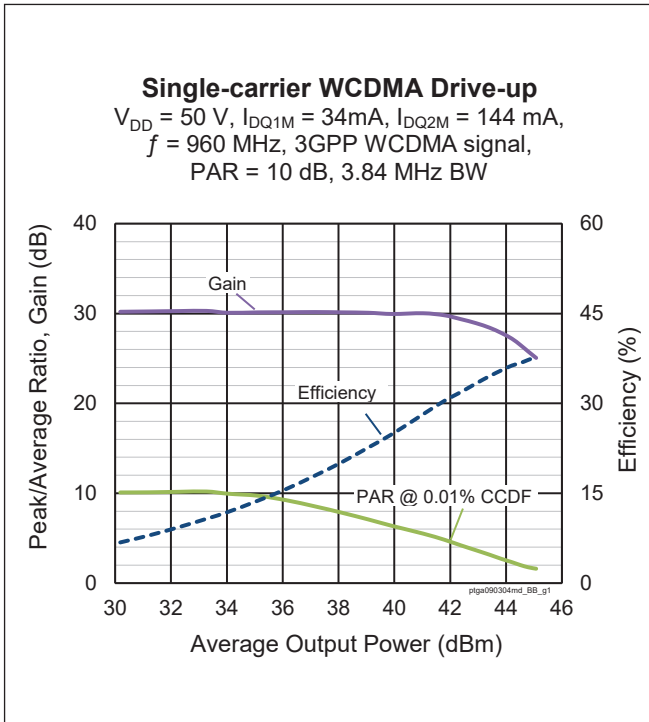

Typical Broadband Performance, 575 – 960 MHz (data taken in test fixture)

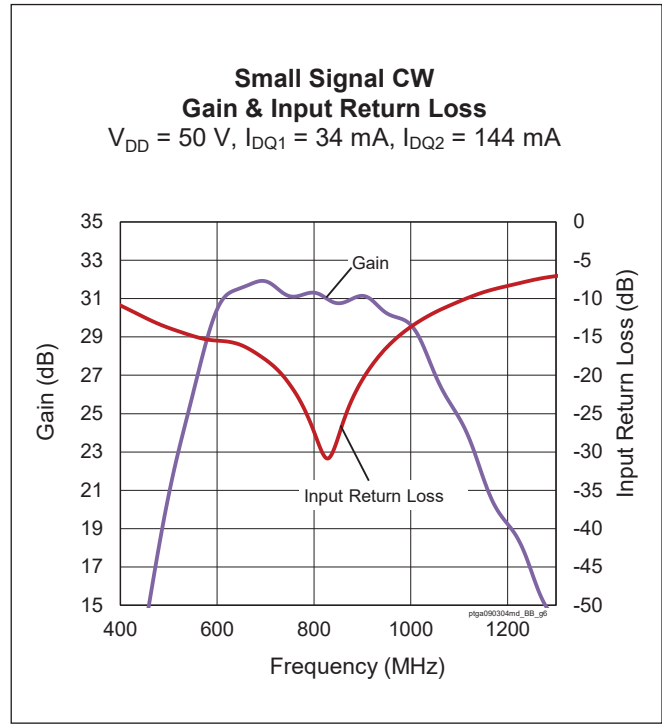
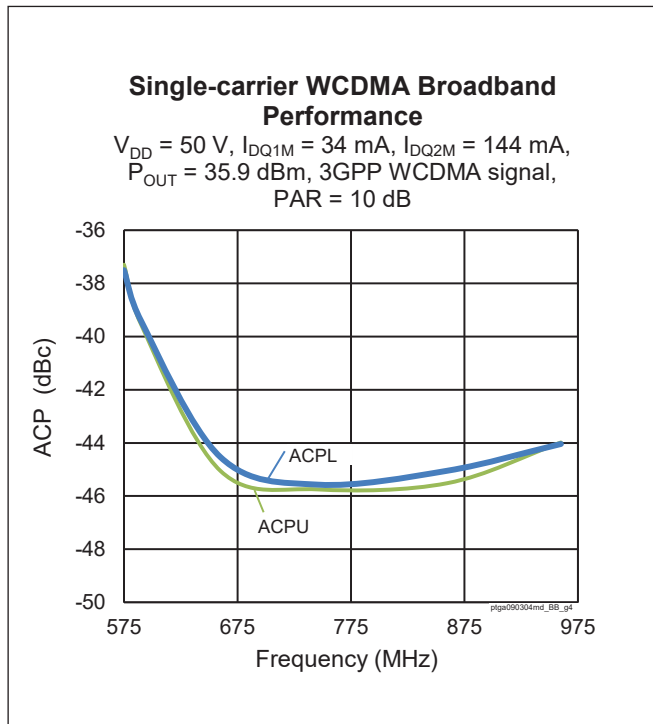

Load Pull Performance

CW signal: 50 V, $I_{DQ} = 17\text{ mA}$, 72 mA

		P _{1dB}									
		Max Output Power					Max PAE				
Freq [MHz]	Z _s [W]	Z _L [W]	Gain [dB]	P _{OUT} [dBm]	P _{OUT} [W]	PAE [%]	Z _L [W]	Gain [dB]	P _{OUT} [dBm]	P _{OUT} [W]	PAE [%]
575	50+j0.00	29.6+j22.6	30.0	42.9	19.3	61.6	13.6+j32.8	34.0	40.4	10.9	72.5
746	50+j0.00	20.8+j18.8	31.3	43.1	20.4	57.1	9+j23.5	34.2	41.0	12.5	66.9
920	50+j0.00	13.8+j16.6	31.6	43.1	20.6	56.3	7+j20.3	34.4	41.3	13.4	68.6
940	50+j0.00	15.4+j16.8	31.4	43.1	20.5	55.3	5.8+j20	35.2	40.5	11.3	70.1
960	50+j0.00	15.6+j16.8	31.7	43.2	20.8	57.6	6+j20	35.8	40.7	11.8	77.5

		P _{3dB}									
		Max Output Power					Max PAE				
Freq [MHz]	Z _s [W]	Z _L [W]	Gain [dB]	P _{OUT} [dBm]	P _{OUT} [W]	PAE [%]	Z _L [W]	Gain [dB]	P _{OUT} [dBm]	P _{OUT} [W]	PAE [%]
575	50+j0.00	29.2+j20.1	27.7	43.5	22.3	60.8	14+j32.8	31.9	41.0	12.5	71.2
746	50+j0.00	18.1+j16.5	29.3	43.8	24.0	58.1	9.5+j23.9	32.1	41.6	14.5	65.4
920	50+j0.00	14.2+j16.6	29.5	43.8	24.1	56.4	6.6+j20	32.5	41.8	15.0	66.2
940	50+j0.00	15.7+j16.5	29.3	43.8	23.9	54.9	5.4+j20	33.4	40.9	12.4	68.1
960	50+j0.00	15.8+j16.5	29.6	43.9	24.5	57.5	6+j20	33.8	41.3	13.5	75.5

*Please note max PAE contours not closed

Reference Circuit, 575 - 960 MHz

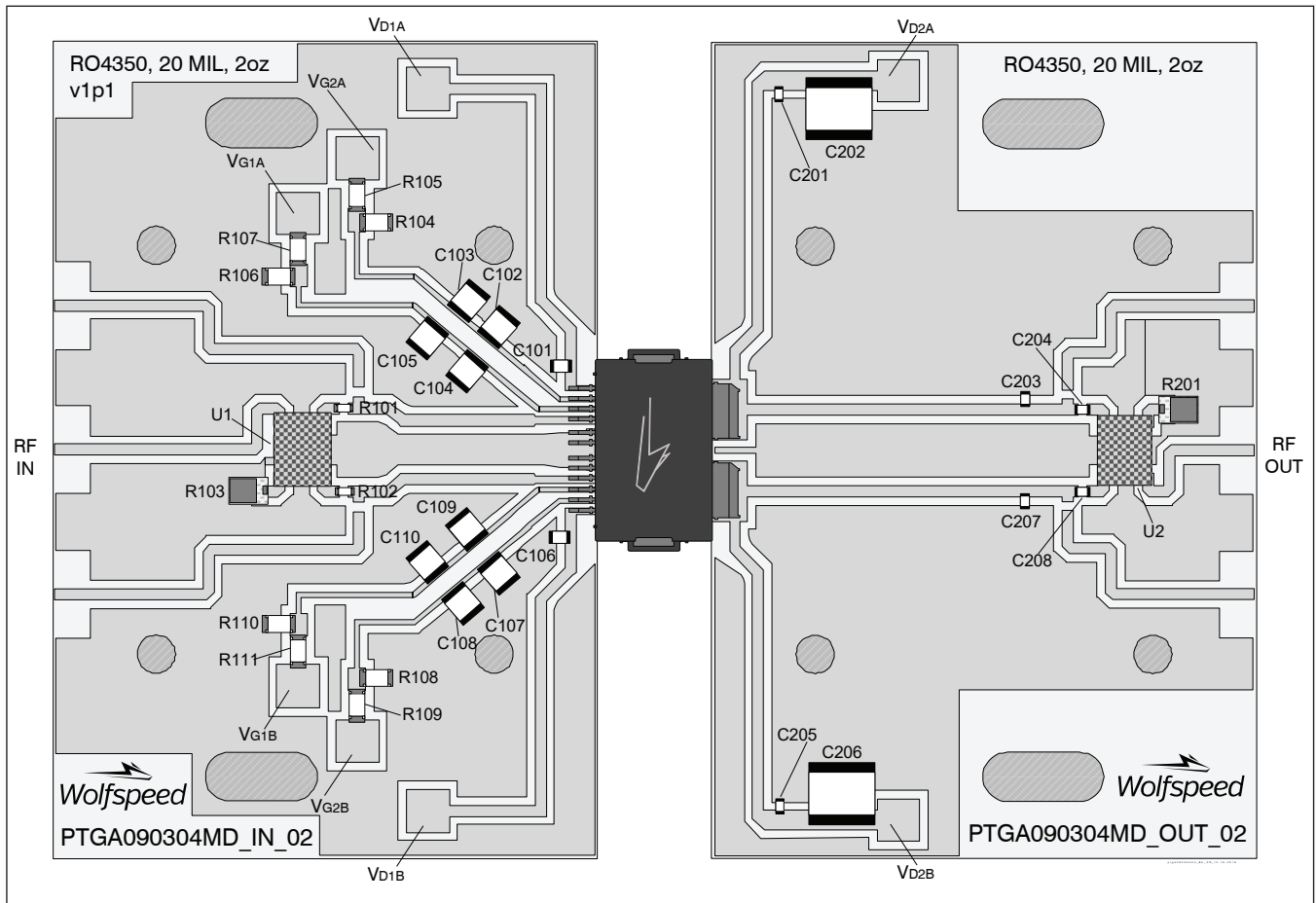

Reference circuit assembly diagram (not to scale)

Reference Circuit Assembly

DUT	PTGA090304MD V2
Test Fixture Part No.	LTN/PTGA090304MD-E3
PCB	Rogers 4350, 0.508 mm [0.020"] thick, 2 oz. copper, $\epsilon_r = 3.66$, $f = 575 - 960$ MHz
Find Gerber files for this test fixture on the Wolfspeed Web site at www.wolfspeed.com/RF	

Reference Circuit, 575 – 960 MHz (cont.)

Components Information

Component	Description	Manufacturer	P/N
Input			
C101, C106	Capacitor, 0.1 μ F	TDK Corporation	C3216X7R2A104M160AA
C102, C104, C107, C109	Capacitor, 10 μ F, 100 V	Murata Electronics North America	GRM32EC72A106KE05L
C103, C105, C108, C110	Capacitor, 4.7 μ F	Murata Electronics North America	GRM32ER71H475KA88L
R101, R102	Resistor, 0.0 ohms	Panasonic Electronic Components	ERJ-3GEY0R00V
R103	Resistor, 50 ohms	Anaren	C8A50Z4A
R104, R106, R108, R110	Resistor, 4.3K ohms	Panasonic Electronic Components	ERJ-8GEYJ432V
R105, R107, R109, R111	Resistor, 1K ohms	Panasonic Electronic Components	ERJ-8GEYJ102V
U1	Hybrid Coupler	Anaren	X3C07P1-03S
Output			
C201, C204, C205, C208	Capacitor, 100 pF	ATC	ATC800A101JT250T
C202, C206	Capacitor, 10 μ F, 100 V	TDK Corporation	C5750X7S2A106M230KB
C203, C207	Capacitor, 1.1 pF	ATC	ATC800A1R1CT250T
R201	Resistor, 50 ohms	Anaren	C8A50Z4A
U2	Hybrid Coupler	Anaren	X3C07P1-03S

Pinout Diagram (top view)

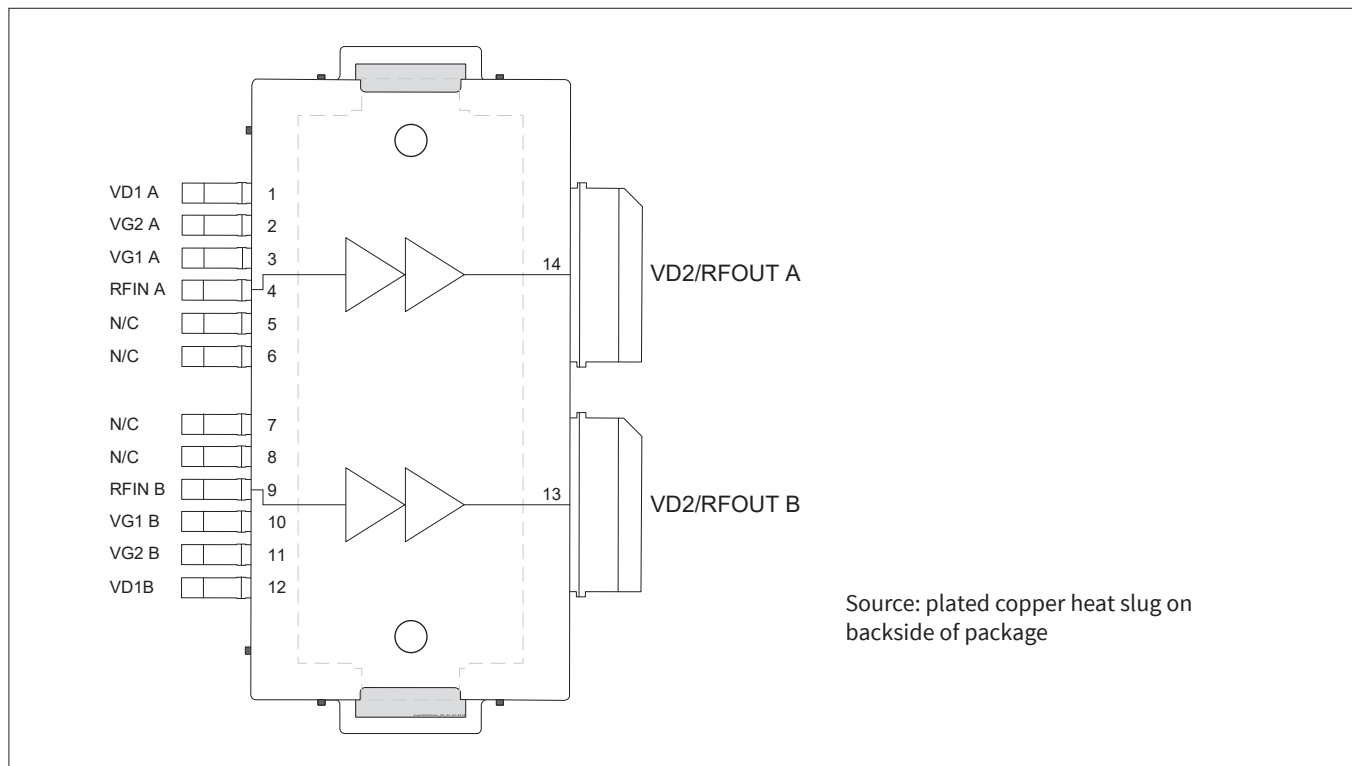

Lead connections for PTGA090304MD

Package Outline Specifications

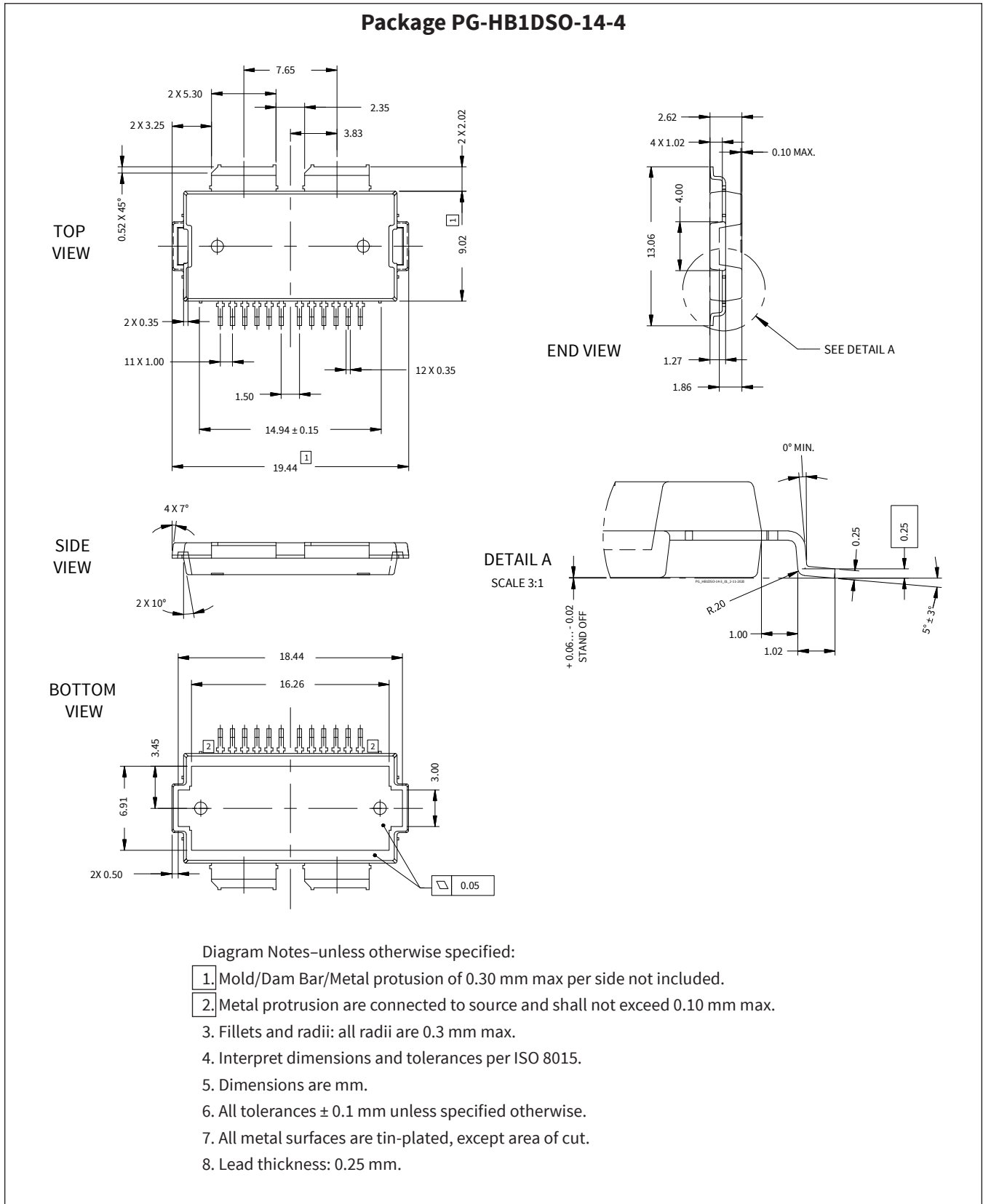

Revision History

Revision	Date	Data Sheet Type	Page	Subjects (major changes since last revision)
01	2018-03-15	Advance	All	Data Sheet reflects advance specification for product development
02	2018-05-01	Advance	All	Converted to Wolfspeed Data Sheet
03	2018-10-17	Production	All	Data Sheet reflects released product specification
04	2020-10-12	Production	All 8	Updated package to V2, revised all package-related information Updated graph
04.1	2020-10-14	Production	6, 9	Corrected fixture part number

For more information, please contact:

4600 Silicon Drive
Durham, North Carolina, USA 27703
www.wolfspeed.com/rf

Sales Contact
rfsales@cree.com

Notes & Disclaimer

Specifications are subject to change without notice. “Typical” parameters are the average values expected by Cree in large quantities and are provided for information purposes only. Cree products are not warranted or authorized for use as critical components in medical, life-saving, or life-sustaining applications, or other applications where a failure would reasonably be expected to cause severe personal injury or death. No responsibility is assumed by Cree for any infringement of patents or other rights of third parties which may result from use of the information contained herein. No license is granted by implication or otherwise under any patent or patent rights of Cree.