

FEATURES

- ESD Protection for RS-232 Bus Pins
 - ± 15 -kV Human-Body Model (HBM)
- Meets or Exceeds the Requirements of TIA/EIA-232-F and ITU v.28 Standards
- Operates at 5-V V_{CC} Supply
- Operates up to 120 kbit/s
- External Capacitors . . . $4 \times 0.1 \mu\text{F}$
- Latch-Up Performance Exceeds 100 mA Per JESD 78, Class II

APPLICATIONS

- Battery-Powered Systems
- PDAs
- Notebooks
- Laptops
- Palmtop PCs
- Hand-Held Equipment

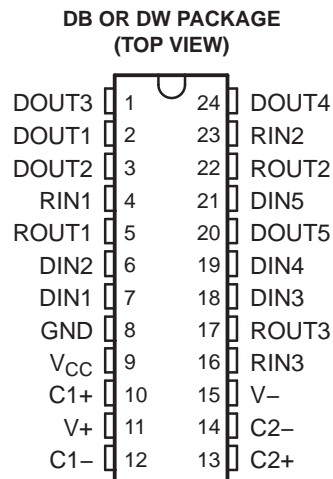

DESCRIPTION/ORDERING INFORMATION

The TRS207 consists of five line drivers, three line receivers, and a dual charge-pump circuit with ± 15 -kV ESD protection pin to pin (serial-port connection pins, including GND). The device meets the requirements of TIA/EIA-232-F and provides the electrical interface between an asynchronous communication controller and the serial-port connector. The charge pump and four small external capacitors allow operation from a single 5-V supply. The devices operate at data signaling rates up to 120 kbit/s and a maximum of 30-V/ μs driver output slew rate.

ORDERING INFORMATION

T_A	PACKAGE ⁽¹⁾⁽²⁾		ORDERABLE PART NUMBER	TOP-SIDE MARKING
0°C to 70°C	SOIC – DW	Tube of 25	TRS207CDW	TRS207C
		Reel of 2000	TRS207CDWR	
	SSOP – DB	Reel of 2000	TRS207CDBR	RU07C
–40°C to 85°C	SOIC – DW	Tube of 25	TRS207IDW	TRS207I
		Reel of 2000	TRS207IDWR	
	SSOP – DB	Reel of 2000	TRS207IDBR	RU07I

- (1) Package drawings, standard packing quantities, thermal data, symbolization, and PCB design guidelines are available at www.ti.com/sc/package.
- (2) For the most current package and ordering information, see the Package Option Addendum at the end of this document, or see the TI Web site at www.ti.com.



Please be aware that an important notice concerning availability, standard warranty, and use in critical applications of Texas Instruments semiconductor products and disclaimers thereto appears at the end of this data sheet.

FUNCTION TABLES

Each Driver⁽¹⁾

INPUT DIN	OUTPUT DOUT
L	H
H	L

(1) H = high level, L = low level

Each Receiver⁽¹⁾

INPUT RIN	OUTPUT ROUT
L	H
H	L
Open	H

(1) H = high level, L = low level,
 Open = input disconnected or
 connected driver off

LOGIC DIAGRAM (POSITIVE LOGIC)

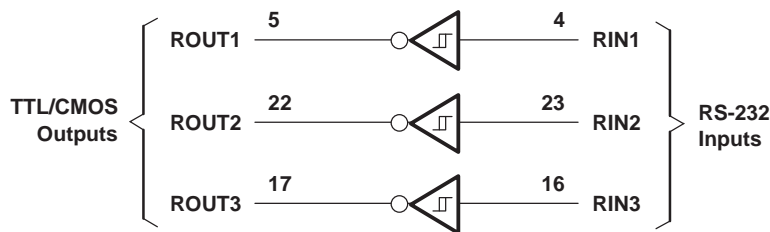
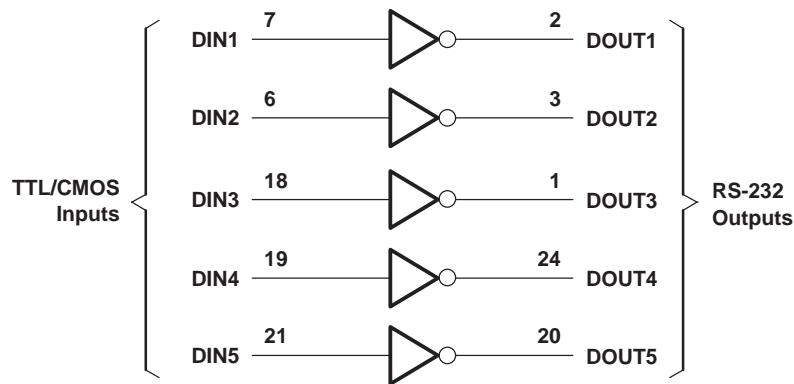

Absolute Maximum Ratings⁽¹⁾

over operating free-air temperature range (unless otherwise noted)

		MIN	MAX	UNIT
V _{CC}	Supply voltage range ⁽²⁾	-0.3	6	V
V+	Positive output supply voltage range ⁽²⁾	V _{CC} - 0.3	14	V
V-	Negative output supply voltage range ⁽²⁾	-14	0.3	V
V _I	Input voltage range	Drivers	V+ + 0.3	V
		Receivers	±30	
V _O	Output voltage range	Drivers	V- - 0.3	V
		Receivers	-0.3	
	Short-circuit duration	DOUT		Continuous
θ _{JA}	Package thermal impedance ⁽³⁾⁽⁴⁾	DB package		63
		DW package		46
T _J	Operating virtual junction temperature			150
T _{stg}	Storage temperature range	-65	150	°C

- (1) Stresses beyond those listed under "absolute maximum ratings" may cause permanent damage to the device. These are stress ratings only, and functional operation of the device at these or any other conditions beyond those indicated under "recommended operating conditions" is not implied. Exposure to absolute-maximum-rated conditions for extended periods may affect device reliability.
- (2) All voltages are with respect to network GND.
- (3) Maximum power dissipation is a function of T_J(max), θ_{JA}, and T_A. The maximum allowable power dissipation at any allowable ambient temperature is P_D = (T_J(max) - T_A)/θ_{JA}. Operating at the absolute maximum T_J of 150°C can affect reliability.
- (4) The package thermal impedance is calculated in accordance with JESD 51-7.

Recommended Operating Conditions⁽¹⁾

See [Figure 4](#)

		MIN	NOM	MAX	UNIT
Supply voltage		4.5	5	5.5	V
V _{IH}	Driver high-level input voltage	2			V
V _{IL}	Driver low-level input voltage			0.8	V
V _I	Driver input voltage	0		5.5	V
	Receiver input voltage	-30		30	
T _A	Operating free-air temperature	TRS207C		70	°C
		TRS207I		85	

- (1) Test conditions are C1–C4 = 0.1 μF at V_{CC} = 5 V ± 0.5 V.

Electrical Characteristics⁽¹⁾

over recommended ranges of supply voltage (unless otherwise noted) (see [Figure 4](#))

PARAMETER	TEST CONDITIONS	MIN	TYP	MAX	UNIT
I _{CC}	Supply current	No load,	V _{CC} = 5 V,	T _A = 25°C	11
					20
					mA

- (1) Test conditions are C1–C4 = 0.1 μF at V_{CC} = 5 V ± 0.5 V.

TRS207

5-V MULTICHANNEL RS-232 LINE DRIVER/RECEIVER WITH ± 15 -kV ESD PROTECTION

SLLS809–JUNE 2007

DRIVER SECTION

Electrical Characteristics⁽¹⁾

over recommended ranges of supply voltage and operating free-air temperature (unless otherwise noted) (see [Figure 4](#))

PARAMETER	TEST CONDITIONS	MIN	TYP ⁽²⁾	MAX	UNIT
V _{OH}	High-level output voltage DOUT at R _L = 3 k Ω to GND, DIN = GND	5	9		V
V _{OL}	Low-level output voltage DOUT at R _L = 3 k Ω to GND, DIN = V _{CC}	–5	–9		V
I _{IH}	High-level input current V _I = V _{CC}		15	200	μ A
I _{IL}	Low-level input current V _I at 0 V		–15	–200	μ A
I _{OS} ⁽³⁾	Short-circuit output current V _{CC} = 5.5 V, V _O = 0 V		± 10	± 60	mA
r _o	Output resistance V _{CC} , V+, and V– = 0 V, V _O = ± 2 V	300			Ω

(1) Test conditions are C1–C4 = 0.1 μ F at V_{CC} = 5 V \pm 0.5 V.

(2) All typical values are at V_{CC} = 5 V, and T_A = 25°C.

(3) Short-circuit durations should be controlled to prevent exceeding the device absolute power dissipation ratings, and not more than one output should be shorted at a time.

Switching Characteristics⁽¹⁾

over recommended ranges of supply voltage and operating free-air temperature (unless otherwise noted) (see [Figure 4](#))

PARAMETER	TEST CONDITIONS	MIN	TYP ⁽²⁾	MAX	UNIT
Maximum data rate	C _L = 50 pF to 1000 pF, One DOUT switching, R _L = 3 k Ω to 7 k Ω , See Figure 1	120			kbit/s
t _{PLH(D)}	Propagation delay time, low- to high-level output C _L = 2500 pF, All drivers loaded, R _L = 3 k Ω , See Figure 1		2		μ s
t _{PHL(D)}	Propagation delay time, high- to low-level output C _L = 2500 pF, All drivers loaded, R _L = 3 k Ω , See Figure 1		2		μ s
t _{sk(p)}	Pulse skew ⁽³⁾ C _L = 150 pF to 2500 pF, See Figure 2		300		ns
SR(tr)	Slew rate, transition region (see Figure 1) C _L = 50 pF to 1000 pF, V _{CC} = 5 V, R _L = 3 k Ω to 7 k Ω	3	6	30	V/ μ s

(1) Test conditions are C1–C4 = 0.1 μ F at V_{CC} = 5 V \pm 0.5 V.

(2) All typical values are at V_{CC} = 5 V, and T_A = 25°C.

(3) Pulse skew is defined as |t_{PLH} – t_{PHL}| of each channel of the same device.

ESD Protection

PIN	TEST CONDITIONS	TYP	UNIT
DOUT, RIN	Human-Body Model	± 15	kV

RECEIVER SECTION

Electrical Characteristics⁽¹⁾

over recommended ranges of supply voltage and operating free-air temperature (unless otherwise noted) (see [Figure 4](#))

PARAMETER		TEST CONDITIONS	MIN	TYP ⁽²⁾	MAX	UNIT
V _{OH}	High-level output voltage	I _{OH} = -1 mA	3.5	V _{CC} - 0.4		V
V _{OL}	Low-level output voltage	I _{OL} = 1.6 mA			0.4	V
V _{IT+}	Positive-going input threshold voltage	V _{CC} = 5 V, T _A = 25°C		1.7	2.4	V
V _{IT-}	Negative-going input threshold voltage	V _{CC} = 5 V, T _A = 25°C	0.8	1.2		V
V _{hys}	Input hysteresis (V _{IT+} - V _{IT-})		0.2	0.5	1	V
r _i	Input resistance	V _I = ± 3 V to ± 25 V	3	5	7	k Ω

(1) Test conditions are C1–C4 = 0.1 μ F at V_{CC} = 5 V \pm 0.5 V.

(2) All typical values are at V_{CC} = 5 V, and T_A = 25°C.

Switching Characteristics⁽¹⁾

over recommended ranges of supply voltage and operating free-air temperature (unless otherwise noted) (see [Figure 3](#))

PARAMETER		TEST CONDITIONS	MIN	TYP ⁽²⁾	MAX	UNIT
t _{PLH}	Propagation delay time, low- to high-level output	C _L = 150 pF		0.5	10	μ s
t _{PHL}	Propagation delay time, high- to low-level output			0.5	10	μ s
t _{sk(p)}	Pulse skew ⁽³⁾			300		ns

(1) Test conditions are C1–C4 = 0.1 μ F at V_{CC} = 5 V \pm 0.5 V.

(2) All typical values are at V_{CC} = 5 V, and T_A = 25°C.

(3) Pulse skew is defined as |t_{PLH} - t_{PHL}| of each channel of the same device.

PARAMETER MEASUREMENT INFORMATION

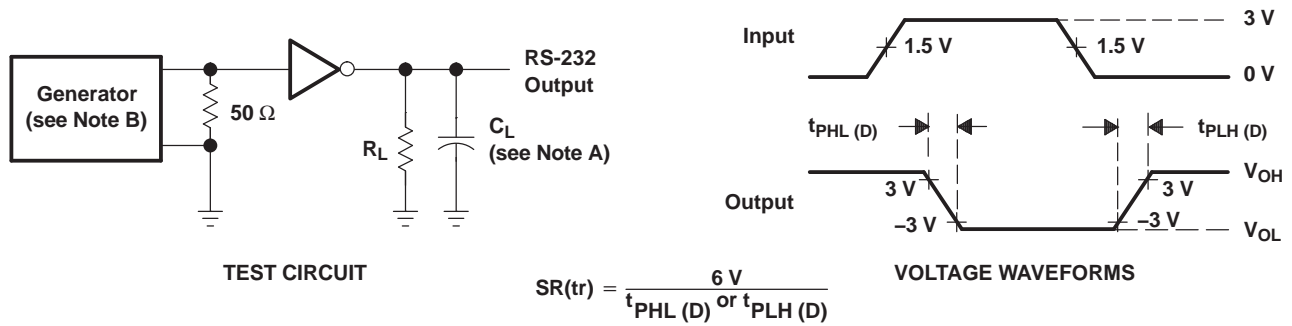

- A. C_L includes probe and jig capacitance.
- B. The pulse generator has the following characteristics: PRR = 120 kbit/s, $Z_O = 50\ \Omega$, 50% duty cycle, $t_r \leq 10\ \text{ns}$, $t_f \leq 10\ \text{ns}$.

Figure 1. Driver Slew Rate

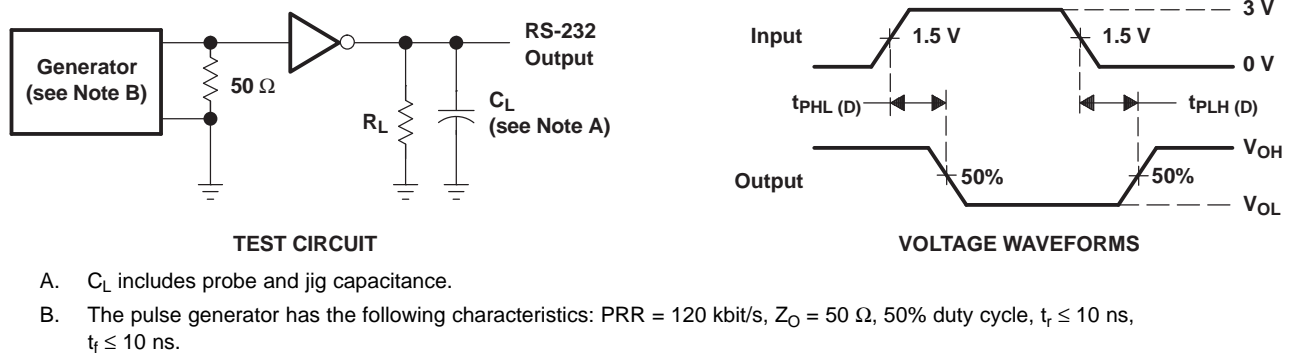

Figure 2. Driver Pulse Skew

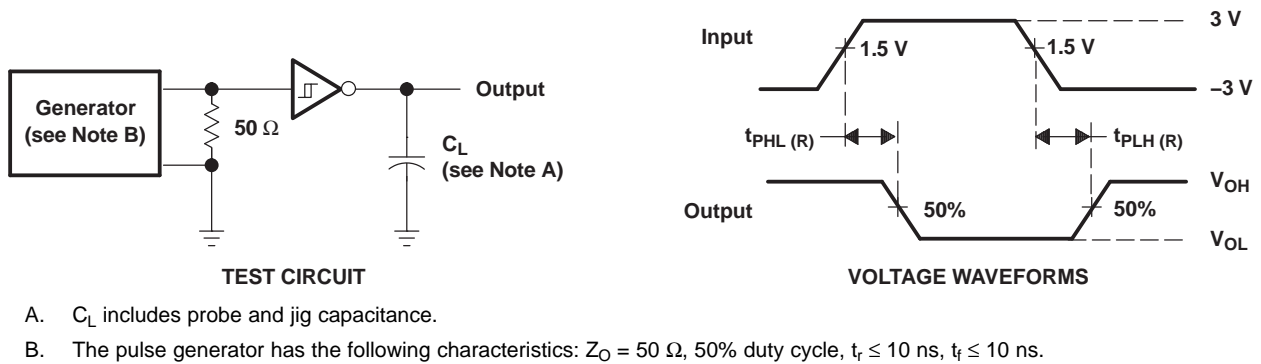
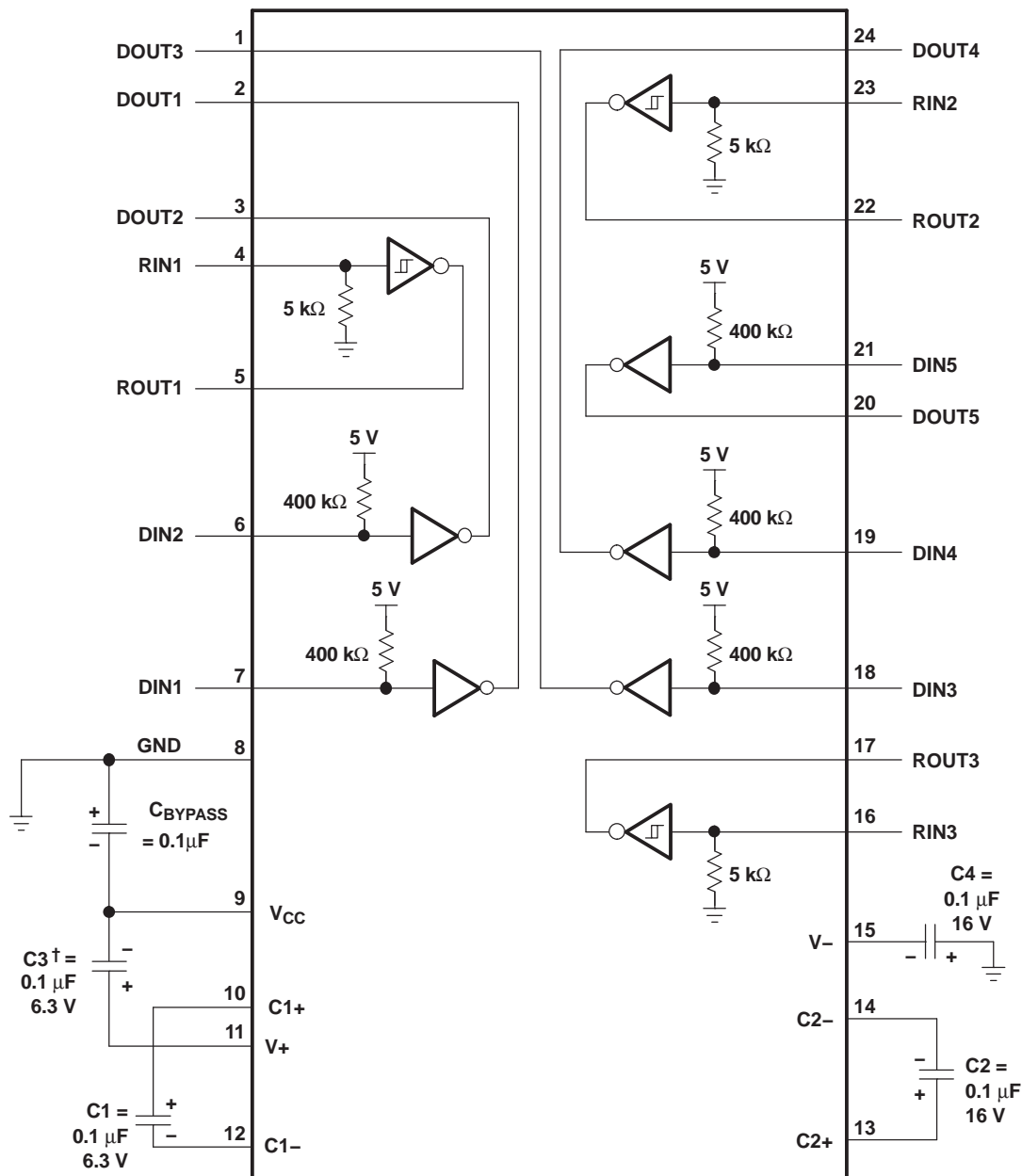

Figure 3. Receiver Propagation Delay Times

APPLICATION INFORMATION



† C3 can be connected to V_{CC} or GND.

- A. Resistor values shown are nominal.
- B. Nonpolarized ceramic capacitors are acceptable. If polarized tantalum or electrolytic capacitors are used, they should be connected as shown.

Figure 4. Typical Operating Circuit and Capacitor Values

APPLICATION INFORMATION (continued)

Capacitor Selection

The capacitor type used for C1–C4 is not critical for proper operation. The TRS207 requires 0.1- μ F capacitors, although capacitors up to 10 μ F can be used without harm. Ceramic dielectrics are suggested for the 0.1- μ F capacitors. When using the minimum recommended capacitor values, make sure the capacitance value does not degrade excessively as the operating temperature varies. If in doubt, use capacitors with a larger (e.g., 2 \times) nominal value. The capacitors' effective series resistance (ESR), which usually rises at low temperatures, influences the amount of ripple on V+ and V–.

Use larger capacitors (up to 10 μ F) to reduce the output impedance at V+ and V–.

Bypass V_{CC} to ground with at least 0.1 μ F. In applications sensitive to power-supply noise generated by the charge pumps, decouple V_{CC} to ground with a capacitor the same size as (or larger than) the charge-pump capacitors (C1–C4).

Electrostatic Discharge (ESD) Protection

TI TRS207 devices have standard ESD protection structures incorporated on the pins to protect against electrostatic discharges encountered during assembly and handling. In addition, the RS-232 bus pins (driver outputs and receiver inputs) of these devices have an extra level of ESD protection. Advanced ESD structures were designed to successfully protect these bus pins against ESD discharge of ± 15 -kV when powered down.

ESD Test Conditions

ESD testing is stringently performed by TI, based on various conditions and procedures. Please contact TI for a reliability report that documents test setup, methodology, and results.

Human-Body Model (HBM)

The HBM of ESD testing is shown in [Figure 5](#), while [Figure 6](#) shows the current waveform that is generated during a discharge into a low impedance. The model consists of a 100-pF capacitor, charged to the ESD voltage of concern, and subsequently discharged into the DUT through a 1.5-k Ω resistor.

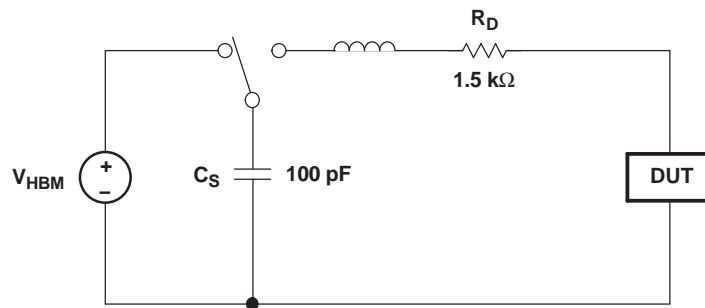

Figure 5. HBM ESD Test Circuit

APPLICATION INFORMATION (continued)

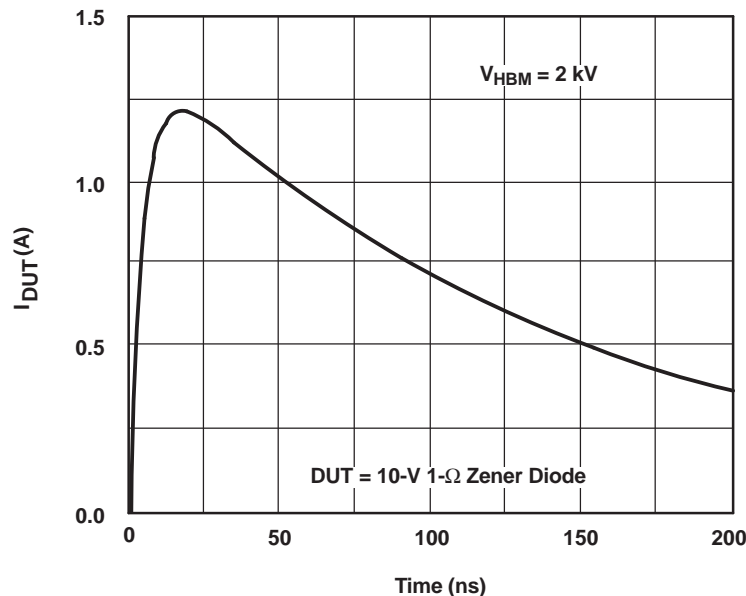

Figure 6. Typical HBM Current Waveform

Machine Model (MM)

The MM ESD test applies to all pins using a 200-pF capacitor with no discharge resistance. The purpose of the MM test is to simulate possible ESD conditions that can occur during the handling and assembly processes of manufacturing. In this case, ESD protection is required for all pins, not just RS-232 pins. However, after PC board assembly, the MM test is no longer as pertinent to the RS-232 pins.

PACKAGING INFORMATION

Orderable Device	Status (1)	Package Type	Package Drawing	Pins	Package Qty	Eco Plan (2)	Lead finish/ Ball material (6)	MSL Peak Temp (3)	Op Temp (°C)	Device Marking (4/5)	Samples
TRS207CDBR	NRND	SSOP	DB	24	2000	RoHS & Green	NIPDAU	Level-1-260C-UNLIM	0 to 70	RU07C	

(1) The marketing status values are defined as follows:

ACTIVE: Product device recommended for new designs.

LIFEBUY: TI has announced that the device will be discontinued, and a lifetime-buy period is in effect.

NRND: Not recommended for new designs. Device is in production to support existing customers, but TI does not recommend using this part in a new design.

PREVIEW: Device has been announced but is not in production. Samples may or may not be available.

OBSELETE: TI has discontinued the production of the device.

(2) **RoHS:** TI defines "RoHS" to mean semiconductor products that are compliant with the current EU RoHS requirements for all 10 RoHS substances, including the requirement that RoHS substance do not exceed 0.1% by weight in homogeneous materials. Where designed to be soldered at high temperatures, "RoHS" products are suitable for use in specified lead-free processes. TI may reference these types of products as "Pb-Free".

RoHS Exempt: TI defines "RoHS Exempt" to mean products that contain lead but are compliant with EU RoHS pursuant to a specific EU RoHS exemption.

Green: TI defines "Green" to mean the content of Chlorine (Cl) and Bromine (Br) based flame retardants meet JS709B low halogen requirements of <=1000ppm threshold. Antimony trioxide based flame retardants must also meet the <=1000ppm threshold requirement.

(3) MSL, Peak Temp. - The Moisture Sensitivity Level rating according to the JEDEC industry standard classifications, and peak solder temperature.

(4) There may be additional marking, which relates to the logo, the lot trace code information, or the environmental category on the device.

(5) Multiple Device Markings will be inside parentheses. Only one Device Marking contained in parentheses and separated by a "-" will appear on a device. If a line is indented then it is a continuation of the previous line and the two combined represent the entire Device Marking for that device.

(6) Lead finish/Ball material - Orderable Devices may have multiple material finish options. Finish options are separated by a vertical ruled line. Lead finish/Ball material values may wrap to two lines if the finish value exceeds the maximum column width.

Important Information and Disclaimer:The information provided on this page represents TI's knowledge and belief as of the date that it is provided. TI bases its knowledge and belief on information provided by third parties, and makes no representation or warranty as to the accuracy of such information. Efforts are underway to better integrate information from third parties. TI has taken and continues to take reasonable steps to provide representative and accurate information but may not have conducted destructive testing or chemical analysis on incoming materials and chemicals. TI and TI suppliers consider certain information to be proprietary, and thus CAS numbers and other limited information may not be available for release.

In no event shall TI's liability arising out of such information exceed the total purchase price of the TI part(s) at issue in this document sold by TI to Customer on an annual basis.

TAPE AND REEL INFORMATION

QUADRANT ASSIGNMENTS FOR PIN 1 ORIENTATION IN TAPE

*All dimensions are nominal

Device	Package Type	Package Drawing	Pins	SPQ	Reel Diameter (mm)	Reel Width W1 (mm)	A0 (mm)	B0 (mm)	K0 (mm)	P1 (mm)	W (mm)	Pin1 Quadrant
TRS207CDBR	SSOP	DB	24	2000	330.0	16.4	8.2	8.8	2.5	12.0	16.0	Q1

TAPE AND REEL BOX DIMENSIONS

*All dimensions are nominal

Device	Package Type	Package Drawing	Pins	SPQ	Length (mm)	Width (mm)	Height (mm)
TRS207CDBR	SSOP	DB	24	2000	356.0	356.0	35.0

IMPORTANT NOTICE AND DISCLAIMER

TI PROVIDES TECHNICAL AND RELIABILITY DATA (INCLUDING DATA SHEETS), DESIGN RESOURCES (INCLUDING REFERENCE DESIGNS), APPLICATION OR OTHER DESIGN ADVICE, WEB TOOLS, SAFETY INFORMATION, AND OTHER RESOURCES "AS IS" AND WITH ALL FAULTS, AND DISCLAIMS ALL WARRANTIES, EXPRESS AND IMPLIED, INCLUDING WITHOUT LIMITATION ANY IMPLIED WARRANTIES OF MERCHANTABILITY, FITNESS FOR A PARTICULAR PURPOSE OR NON-INFRINGEMENT OF THIRD PARTY INTELLECTUAL PROPERTY RIGHTS.

These resources are intended for skilled developers designing with TI products. You are solely responsible for (1) selecting the appropriate TI products for your application, (2) designing, validating and testing your application, and (3) ensuring your application meets applicable standards, and any other safety, security, regulatory or other requirements.

These resources are subject to change without notice. TI grants you permission to use these resources only for development of an application that uses the TI products described in the resource. Other reproduction and display of these resources is prohibited. No license is granted to any other TI intellectual property right or to any third party intellectual property right. TI disclaims responsibility for, and you will fully indemnify TI and its representatives against, any claims, damages, costs, losses, and liabilities arising out of your use of these resources.

TI's products are provided subject to [TI's Terms of Sale](#) or other applicable terms available either on [ti.com](https://www.ti.com) or provided in conjunction with such TI products. TI's provision of these resources does not expand or otherwise alter TI's applicable warranties or warranty disclaimers for TI products.

TI objects to and rejects any additional or different terms you may have proposed.

Mailing Address: Texas Instruments, Post Office Box 655303, Dallas, Texas 75265
Copyright © 2023, Texas Instruments Incorporated